



The all-steel Flex-Form system gives you all the strength and versatility you expect from Symons. Flex-Form has integral 4" deep vertical stiffeners with 3/16" steel skin plate to provide up to a 1,200 psf system that adapts to any radius 5' and over.

F
FORMTECH
concrete forms, inc

800.876.4857 | formtechinc.com

SYMONS[®]
BY DAYTON SUPERIOR

Table of Contents

I.	Introduction.....	1
II.	Basic Elements Of The System	1
A.	Standard Panels	1
B.	Panel End Rail Bolt Spacing.....	2
C.	Interior Stiffeners.....	3
D.	Rolled Ribs	3
E.	Straight Ribs	5
F.	Fillers	6
G.	System Accessories	7
III.	Assembling Gangs	7
A.	Preparing For Gang Assembly	7
B.	In Place Assembly (inside and outside gangs)	7
C.	Flat Gang Assembly (horizontal)	11
D.	Rib Field Installation	11
F.	Void Panel.....	15
G.	Pour Door Panel	17
IV.	Accessory Installation	17
A.	Tie Bearing Bracket	17
B.	Top Tie/Lift Bracket	17
C.	Panel Aligner Plate.....	19
D.	Plywood extension/ Alignment bracket	19
E.	Ladder Connector Bracket.....	21
F.	Walers.....	22
G.	Anchor Clamp Adaptor - Multi-Lift Pours.....	22
H.	Walkway Brackets	25
I.	Wall Ties.....	26
VI.	Special Applications	27
A.	Tension/Compression Ring	27
B.	Bullnose	27
C.	Pier Cap Radius Soffit.....	27
D.	Ogee Curve	28
E.	Arch Culvert Radius Soffit	28

I. INTRODUCTION

Flex-Form is an all steel forming system. It is a tied system designed for 1200 psf concrete pressure, except the 6'-0" panels. The 6'-0" panels are designed for 1000 psf concrete pressure. Bolt-on top and bottom, rolled, horizontal ribs provide the panel's $\frac{3}{16}$ " skin plate with a smooth, non-chorded, true radius forming surface. Panels are designed to be stand-alone, tied units. Speed Bolts ($\frac{1}{2}$ " diameter) are spaced at 1'-0" o.c. in horizontal and vertical joints.

The modular components are designed for optimum gang size and handling for use in waste water treatment plant tank walls, other curved wall applications, serpentine walls and certain shaft applications. Using a straight rib, Flex-Form produces straight walls as well.

CAUTION: Flex-Form panels must not be used in plate girder applications.

II. BASIC ELEMENTS OF THE SYSTEM

A. Standard Panels

1. Panels are comprised of $\frac{3}{16}$ " steel skinplate and 4" deep bent channel stiffeners. The stiffeners always run parallel to the width dimension of the panel.
2. Interior stiffeners are $\frac{3}{16}$ " thick bent channels while exterior (end rail) stiffeners are $\frac{1}{4}$ " thick bent channels.
3. See figure for standard available Flex-Form panel sizes with identifying Product Codes.

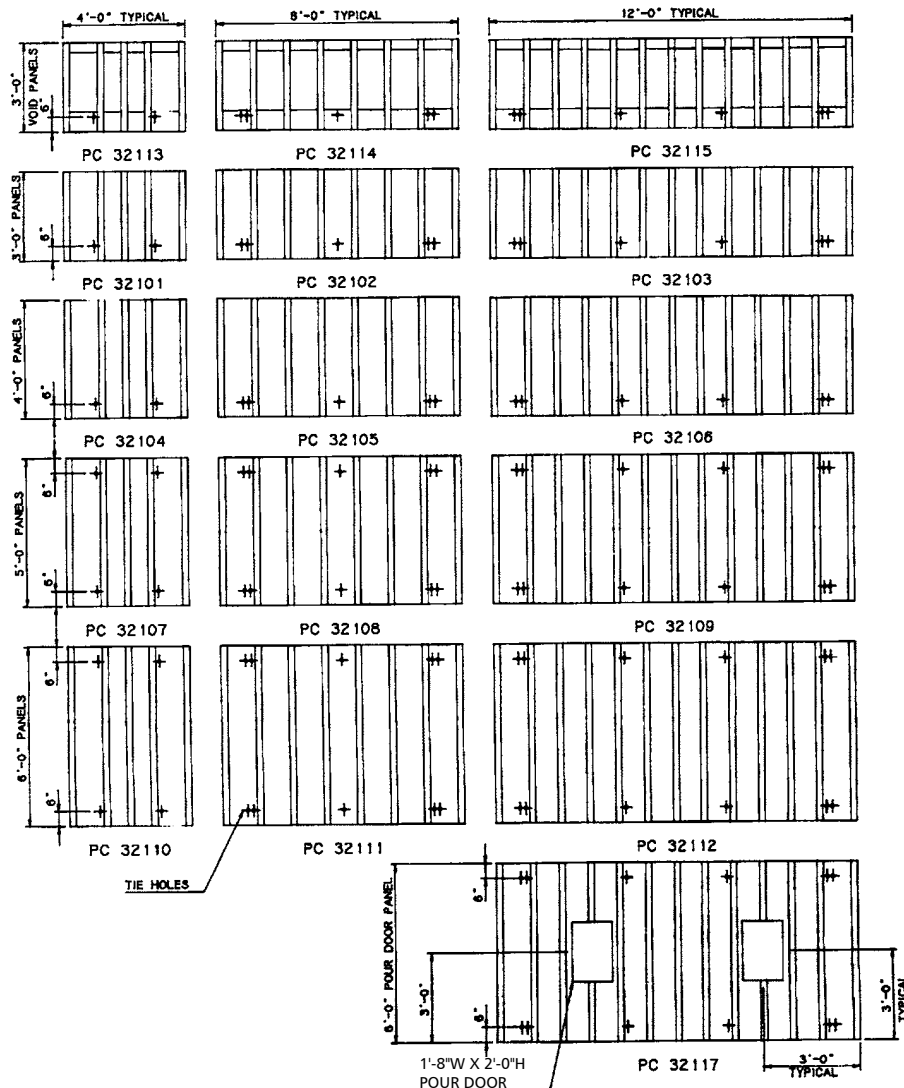

B. Panel End Rail Bolt Spacing

1. Panel end rails are punched with a combination of slots and holes as depicted on the details sketched. There are two distinct gage lines. The $1\frac{3}{4}$ " gage line connects adjacent panels, Max-A-Form® and column forms. The $1\frac{7}{16}$ " gage line connects Steel-Ply® and acts as an alternate connection for adjacent panels and Max-A-Form.

2. Connecting hardware is the $\frac{3}{4}$ " x 2" Speed Bolt which is a high strength A325 bolt with modified Acme thread. Preferred bolt location is 1'-0" on center beginning 6" from each end. Use slots for initial fit-up and holes for final alignment

3. All bolts should be only slightly tightened during initial assembly. Final tightening should be performed when final alignment is achieved. Specified bolt torque is not required.

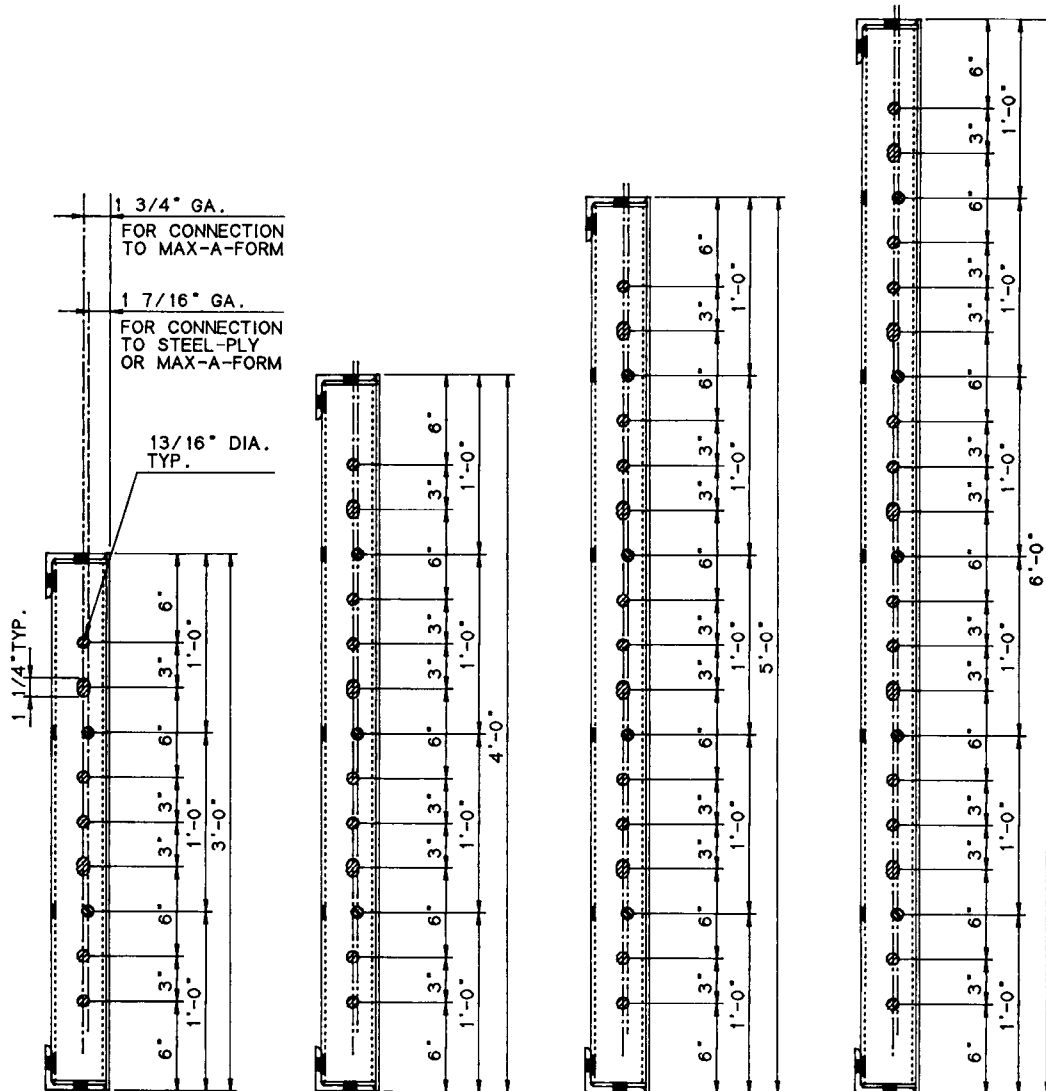

END RAIL HOLE PATTERN

C. Interior Stiffeners

1. Interior stiffeners are punched with $\frac{3}{16}$ " diameter holes typically at 3" centers, except for 4" end spacing and center spacing as depicted in detailed sketch. These holes, referred to as accessory holes, are intended for the attachment of various accessories, e.g. Walkway Brackets, Ladder Brackets, Pipe Form Aligners, etc.
2. Interior stiffeners of void panels have additional holes in inner and outer flanges to facilitate attachment of $\frac{1}{2}$ " plywood by contractor. Inner flanges have $\frac{1}{16}$ " holes at 6" centers for customer attachment hardware. Outer flanges have $\frac{13}{16}$ " dia. clearance holes at three (3) locations for insertion of screwdriver or socket. See section III for further information on void panel plywood attachment.

D. Rolled Rib

1. Rolled ribs are a structural angle $4 \times 3 \times \frac{3}{8}$ " rolled at the factory to the required radius for each particular order. The rolled ribs are the backbone of the Flex-Form system. The purpose of the ribs are two-fold. To hold the flex panel to the proper radius and to act as the load gathering member of the system. See detailed sketch for slot spacing on following page.

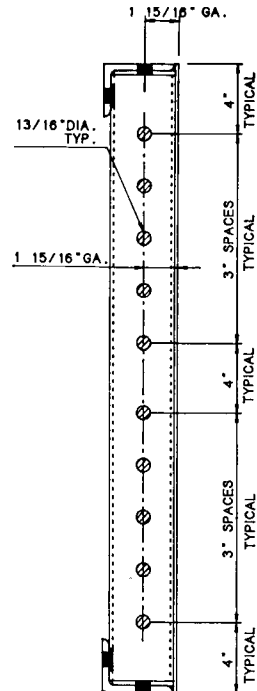

INTERIOR STIFFENER HOLE PATTERN

ROLLED RIBS

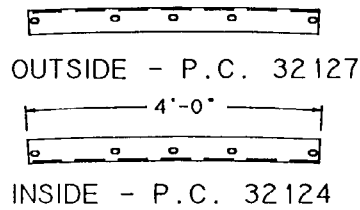
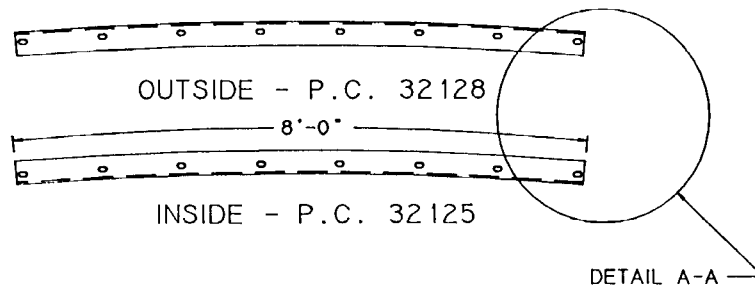
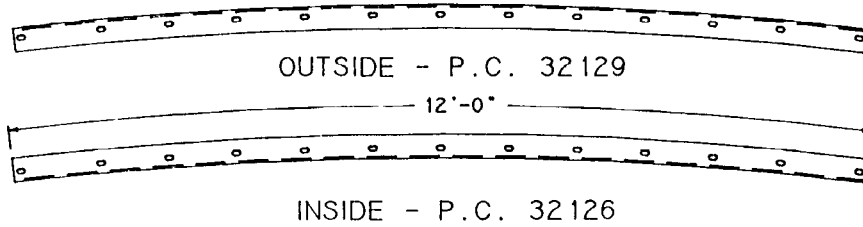

NOTE 1: For hole spacing see page 6

2: Ribs may not be substituted on panels of equivalent length. I.e. Two 4'-0" ribs will not bolt to an 8'-0" panel, ETC.

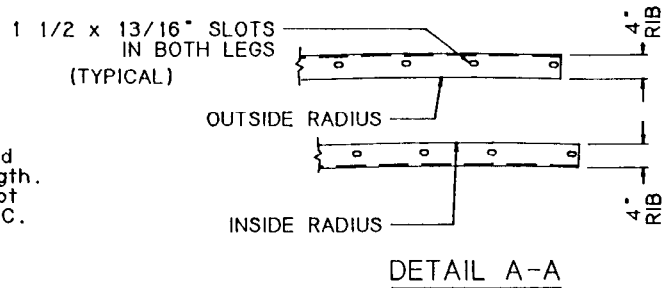

E. Straight Ribs

1. Straight ribs are the same structural angle section as the rolled rib and will hold the flex panel in a straight position. See detailed sketch below.

STRAIGHT RIBS

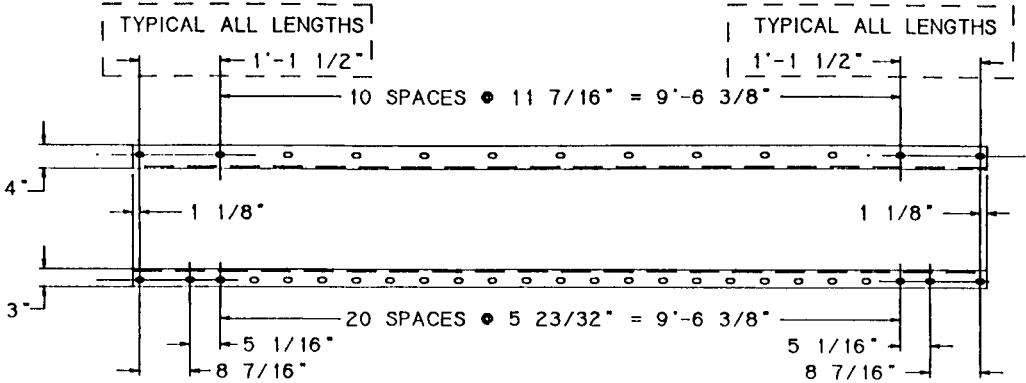

12' STRAIGHT RIB - P.C. 32123

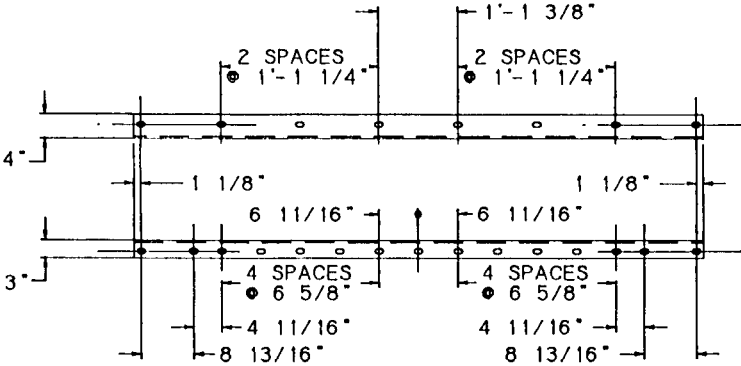

8' STRAIGHT RIB - P.C. 32122

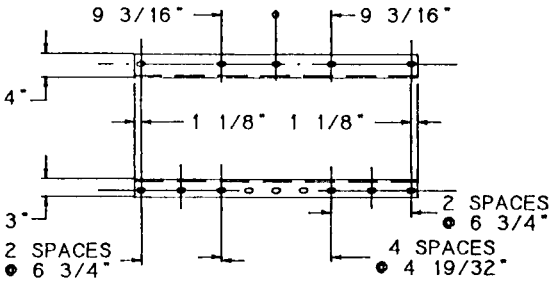

4' STRAIGHT RIB - P.C. 32121

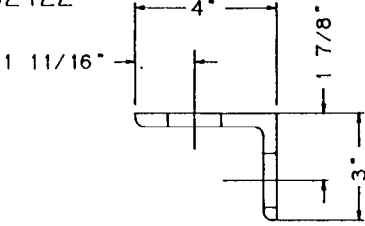

TYPICAL ALL LENGTHS

- NOTE 1: Hole spacing for rolled ribs identical.
- 2: Ribs may not be substituted on panels of equivalent length. I.e., Two 4'-0" ribs will not bolt to an 8'-0" panel, etc.
- 3: All slots are 1 1/2 X 13/16" (Typical)

F. Fillers

1. Flex-Form fillers are used to compensate for the gain in circumference in outside radius gangs. The necessity for the fillers is to minimize the offset between inside and outside tie holes.
2. Flex-Form fillers are furnished in widths of 3", 4", 6" and 8" and in lengths of 3'-0", 4'-0", 5'-0", and 6'-0". The fillers consist of 10 ga. steel plate with 3 1/2"x3/8" end rails and are rated at 1500 psf capacity

3. The unique feature of the Flex-Form filler is the ability to bolt to Flex-Form, Max-A-Form, Versiform® and Steel-Ply. The end rail is punched with a variety of holes and slots to accomplish this. See detailed sketch for dimensions.

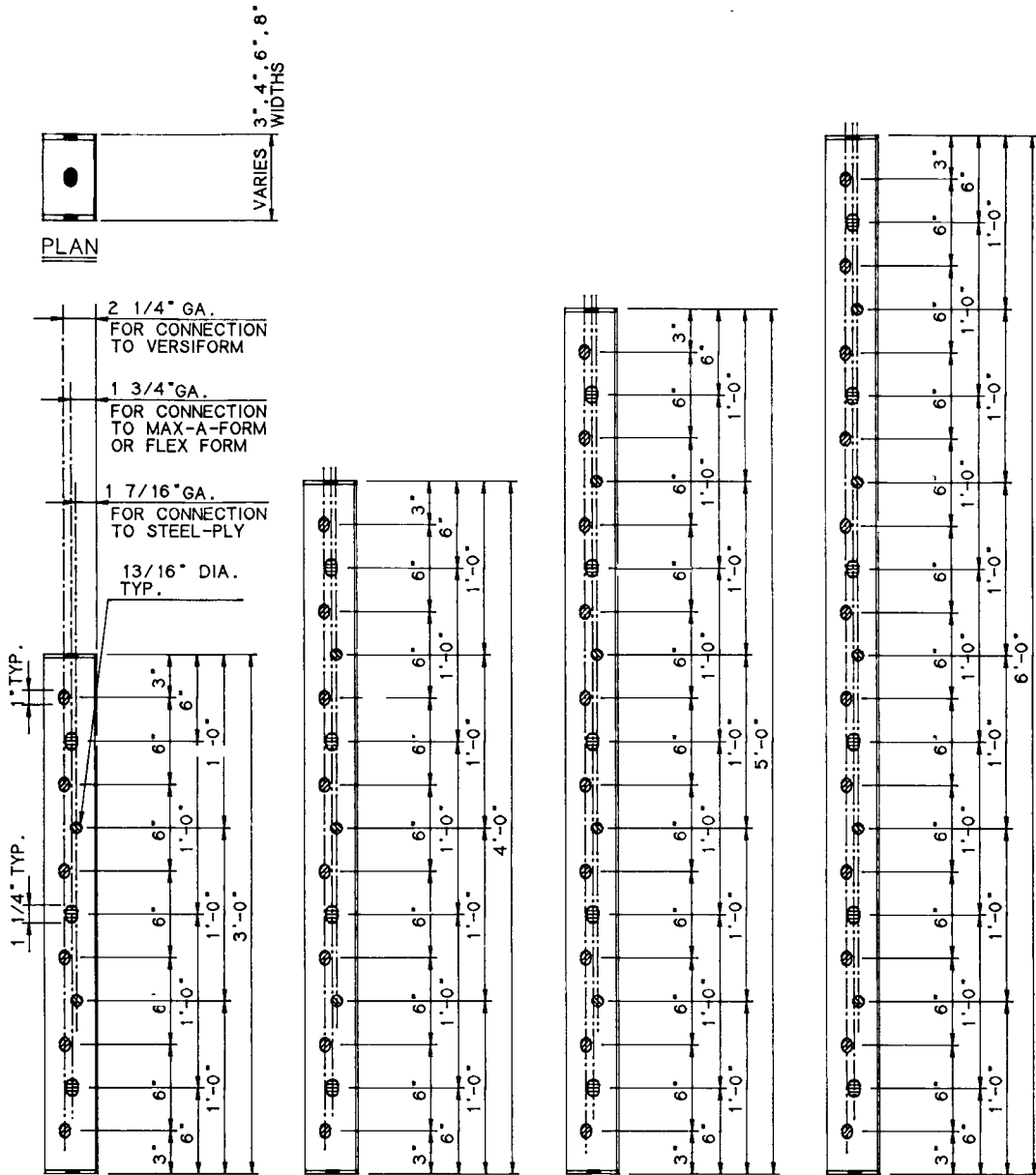

FILLER PANEL HOLE PATTERN

G. System Accessories

1. Several product accessories are exclusive to the Flex-Form system. Following are those items with corresponding product code and function.
 - a. Tie Bearing Bracket, PC32171, transfers tie load to rolled rib.
 - b. Top Tie/Lift Bracket, PC32172, acts as top tie bracket and lifting bracket for individual panels and gangs.
 - c. Panel Aligner Plate, PC32173, bolted across horizontal panel joints and used in lieu of walers for panels stacked 20'-0" high or less.
 - d. Waler Connector Channel, PC32174, used to attach waler to Flex-Form rib.
 - e. Plywood Extention/Alignment Bracket, PC32175, bent angle member used to attach up to 6" of 1/2" plywood at top of form gang or as an alignment/anchoring device to slab.
 - f. Anchor Camp Adapter, PC32176, used in conjunction with Max-A-Form® Anchor Clamp and Thrust Bolt for support or multi-lift gangs.
 - g. Tie Bracket Angle, PC32181, is attached to an ear on the Batter Plate Casting to prevent rotation.
 - h. Ladder Connector Bracket, PC32177, will allow attachment of Standard Column Form Ladders.

III. ASSEMBLING GANGS

A. Preparing For Gang Assembly

1. In most cases Flex-Form gangs can and should be erected in place. Gangs may be erected on footing or slab and gangs set and aligned in position for first pour. Jobsite conditions and contractor handling equipment and/or preference will dictate procedure. As with any assembly sequence the first step is to "shake-out" equipment. Check equipment against shipping ticket, if any equipment is missing, it may be early enough to prevent any substantial delay.
2. To prepare panels for assembly, some accessories may be attached. Tie Bearing Brackets, Top Tie Lift Brackets and to some extent Aligner Plates may be installed prior to raising panels in place, after installing Tie Bearing Brackets shipping bolts at top and bottom ribs may be removed.

CAUTION: Install Tie Bearing Brackets prior to removing shipping bolts.

B. In Place Assembly (inside and outside gangs)

1. Prior to this step the contractor should establish work points on slab. This is accomplished by either a starter wall or chalk line or points to establish position of form gang. In some cases where slab surface is rough or inconsistent it may be necessary to install a sill plate.
2. Establish first panel position. For instance, if centerline of pour coincides with a vertical joint use this as a point of reference and work out from centerline. Although not critical, working from centerline of pour at both inside and outside gangs seems to yield better results.
3. With panel aligned properly, install two (2) Plywood Ext./Aligner Brackets (PC32175) approximately 18" from each end of panel. This step is particularly recommended when a starter wall is not utilized in order to maintain proper wall spacing. Anchor to slab with anchor bolt; typically used is a self-tapping or shot driven anchor bolt in the 3/8" diameter range. Remember; these anchors serve only to hold bottom of gang in position and are not intended to carry any concrete load. Position and align adjacent panel, install joint bolts but do not fully tighten

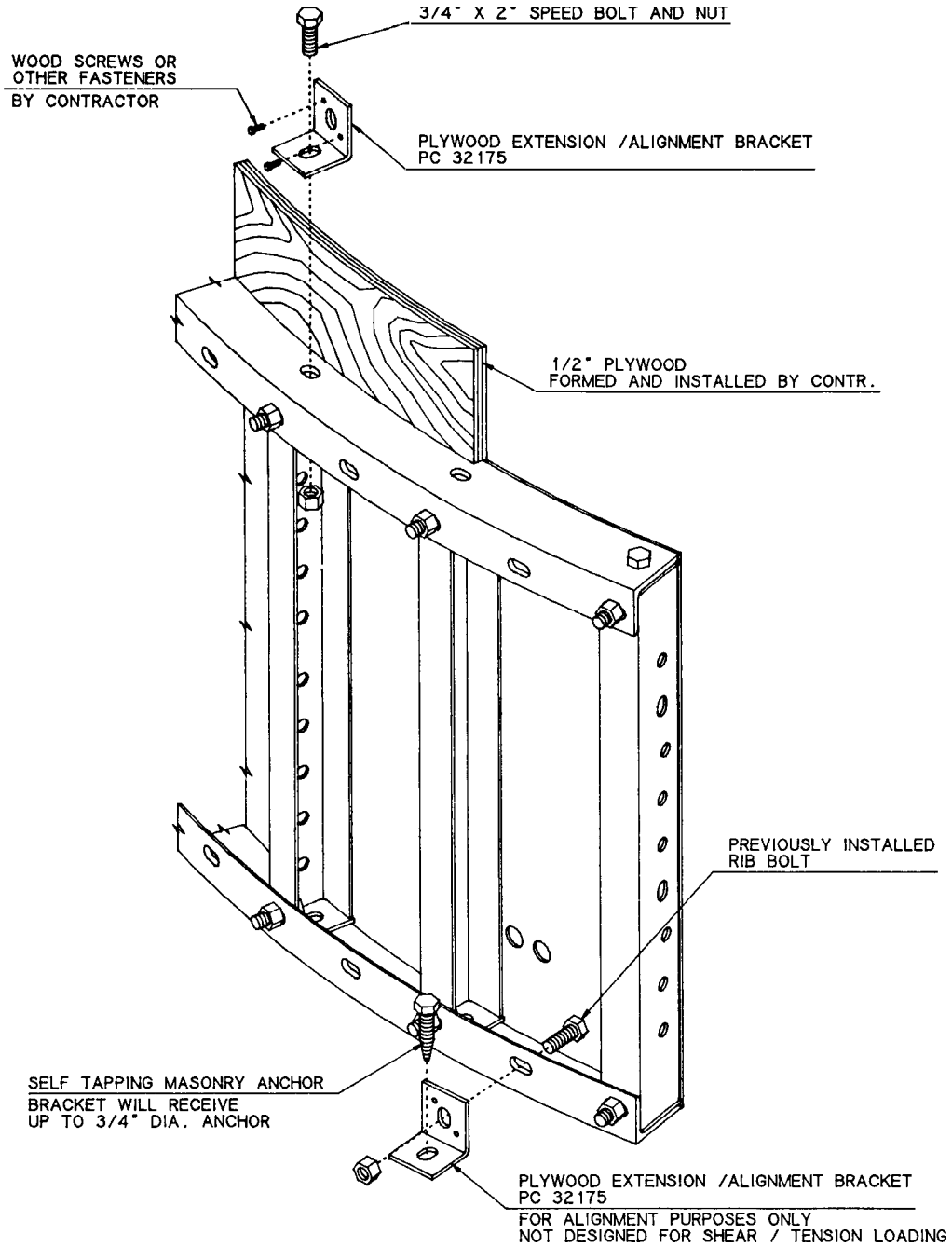

at this time. Complete alignment of panel and secure to slab with one (1) Alignment Bracket and anchor at panel end away from last anchor. Continue with remaining panels on first lift using one Alignment Bracket and anchor per panel section. When alignment is complete and satisfactory, fully tighten all joint bolts.

Temporary bracing is required when building gangs. Depending on gang size several connections may be required prior to installing predetermined bracing.

It should be noted here, it is customary to build inside wall gangs first since usually no fillers are used, then line up outside panels to inside with like panels opposing like panels. Align using panel centerline (not joints) as point of reference or workpoint. This will usually assure proper alignment of tie holes.

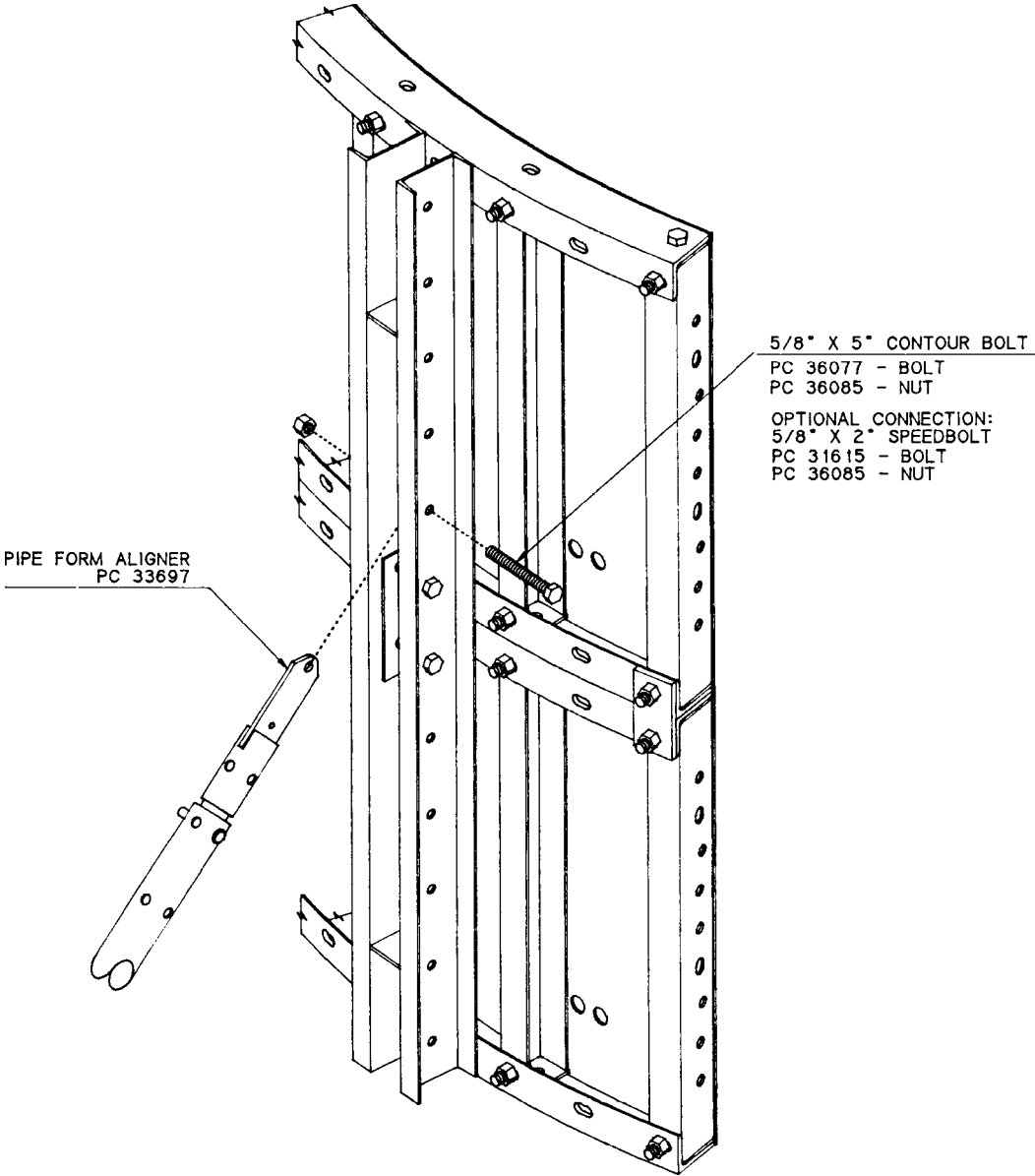

With first lift established, the remainder of gang may be assembled using the following guidelines.

- Stack like panels atop like panels (Flex-Form panels cannot be brick patterned or offset) and install $\frac{3}{4}$ " x 3" or 4" long bolts. Fully tighten only after achieving satisfactory alignment.
- Install $1\frac{5}{16}$ " dia. plastic plugs in those tie holes which will not be used. Only one of the dual tie holes at the ends of 12'-0" and 8'-0" long panels will be used. Determine which of these holes to plug and do so before installing outside panel/gang.
- Install remainder of aligner plates and complete alignment and bolt installation. Check to see that all previously installed bolts are tightened.
- Attach walers if necessary (20'-0" or higher gangs)
- Secure gangs with recommended plumbing braces.
- Establish wall thickness at top of gang using lag-stud with double nuts, or another wall tie at each Top Tie/Lift Bracket location.
- Install 50K Taper Ties and Batter Plate Castings at required locations. Attach Tie Bracket Angle to Batter Plate Casting with $\frac{1}{2}$ " Machine Bolt and Nut.
- Complete final plumbing and install bulkheads.

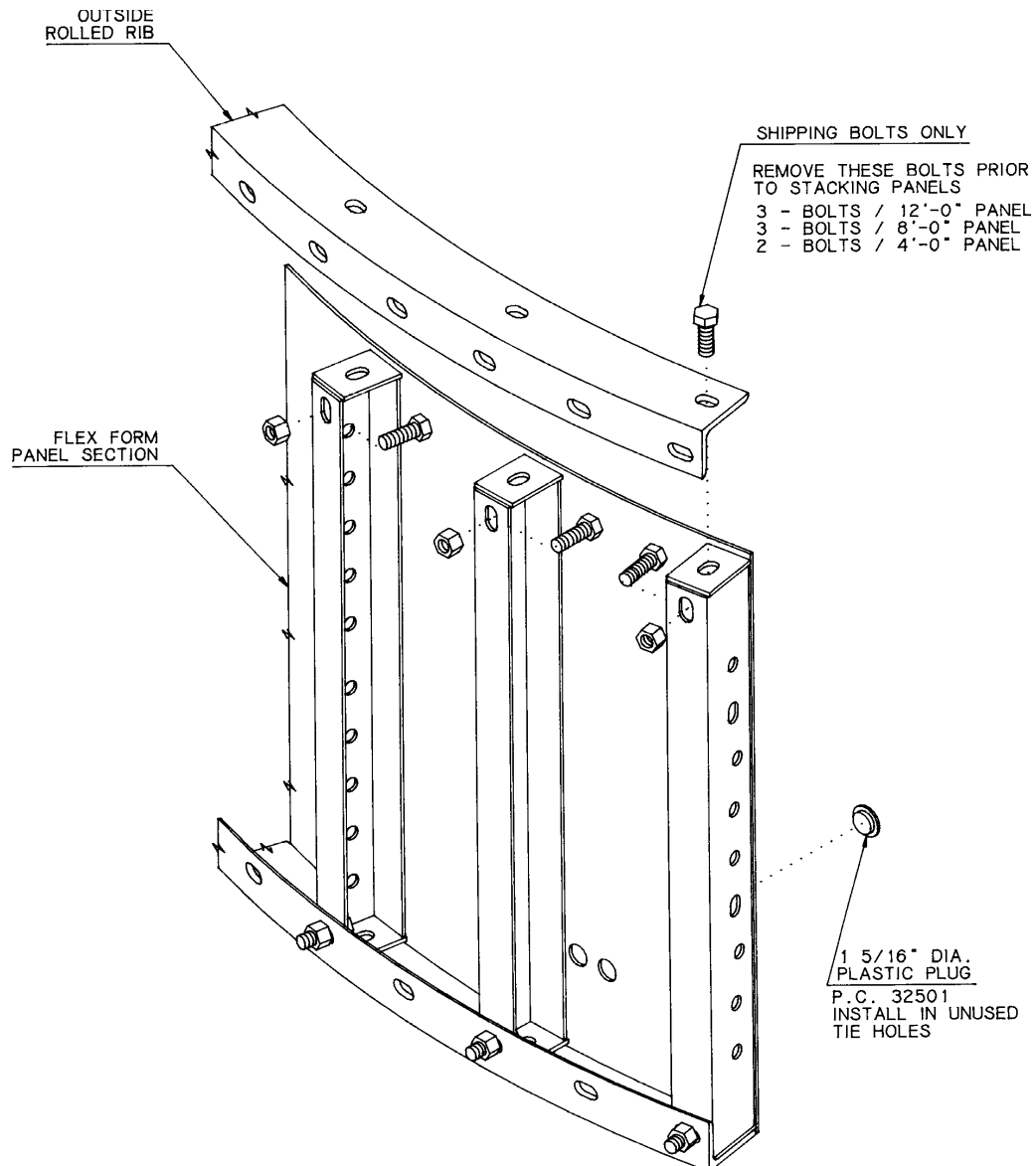

C. Flat Gang Assembly (horizontal)

1. Although generally the exception, Flex-Form gangs may be assembled in the flat or horizontal mode. Certain factors may make it necessary to assemble in this fashion, not the least of which is contractor preference.
2. The requisite here is that sleepers or risers be utilized to support curved panels and protect the skin plate from damage. See figure below. When erecting in this fashion aligner plates and/or walers should be tightened and secured before tightening horizontal joint bolts. All other procedures applicable to vertical stacking will apply here also.
3. Care should be exercised when lifting gang from horizontal to vertical. A final alignment is recommended before anchoring and bracing is completed.

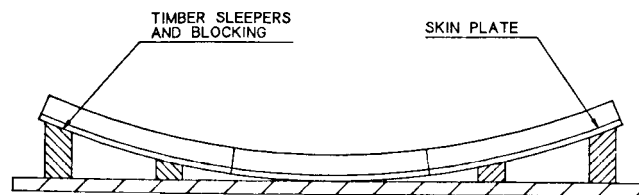

INSIDE GANG ASSEMBLY

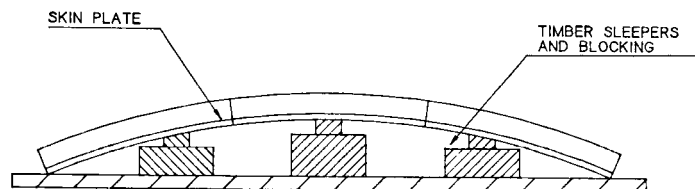

OUTSIDE GANG ASSEMBLY

D. Rib Field Installation

1. One of the notable features of Symons Flex-Form is that panels are shipped with the rolled ribs installed. However, on large jobs requiring different radii, rib change-out in the field becomes necessary. To accomplish this requires minimal installation labor. Generally a two-man operation, a third can assist in aligning ribs and installing bolts. This procedure does necessitate disassembly of the gang.

CAUTION: Exercise care when removing rolled ribs from panels due to panel "springback"

See illustrations on pages 12 thru 14 and refer to the following notes:

- Allow $\frac{1}{4}$ " to $\frac{3}{8}$ " set back at end of rib in relation to end of panel.
- When installing rib bolts be sure rolled rib is tight against end of stiffener.

OUTSIDE RIB INSTALLATION

NOTE: This section deals with reinstallation of rolled ribs should a field change be necessary. Panels are shipped with all rib face bolts installed and a minimum number in horizontal leg which are removed for stacking and form on grade.

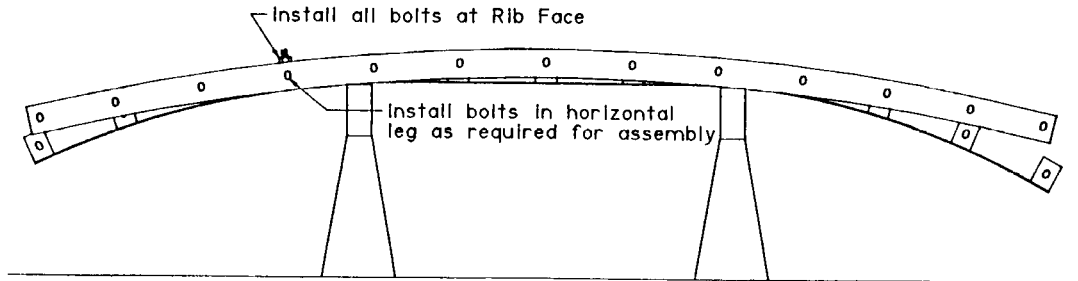

STEP 1

- A. Set panel on sawhorse or assembly fixture as shown.
- B. Position rib and begin bolt installation. Finger tighten only.

CAUTION
EXERCISE CARE WHEN REMOVING ROLLED RIBS FROM
PANELS, DUE TO PANEL "SPRING BACK".

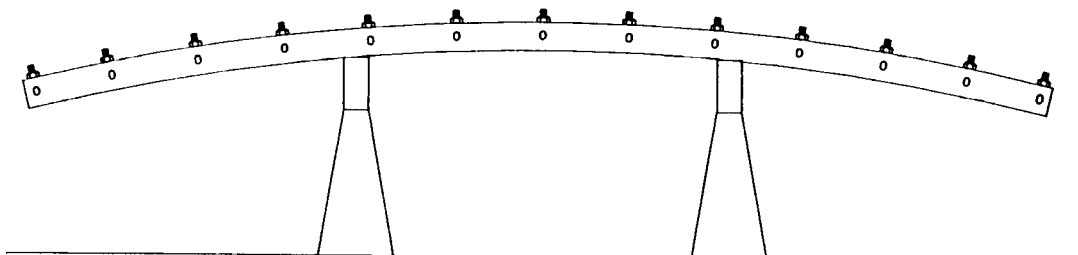

STEP 2

- A. Complete installation of bolts.
Bolts are required at EACH stiffener location.
- B. Check alignment of ribs at ends of panel and tighten bolts

INSIDE RIB INSTALLATION

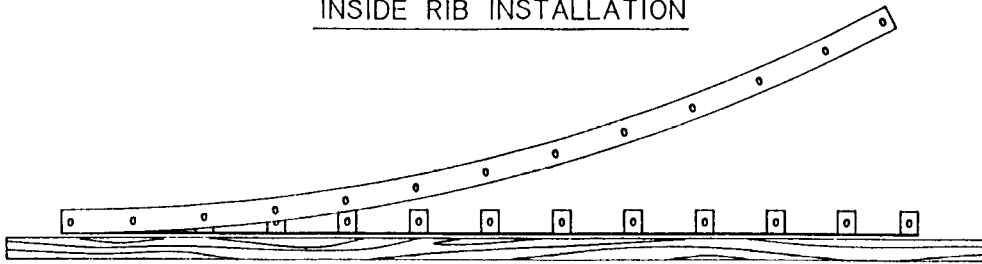

STEP 1

- A. Lay panel section on wood sleepers to protect Skin Plate.
- B. Install bolts from one end of ribs. Finger tighten.

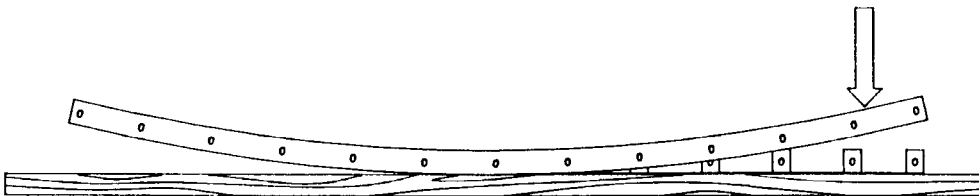

STEP 2

- A. Continue bolt installation by applying force at free end of rib.

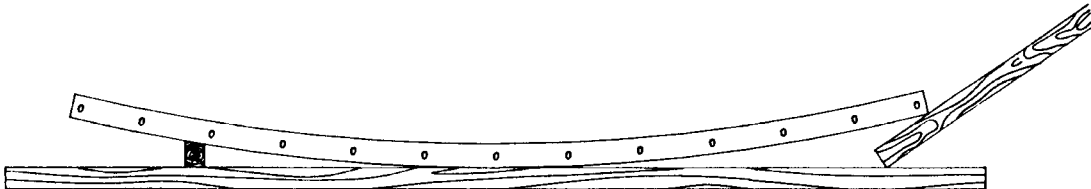

STEP 3

- A. Final bolt installation may require raising panel to rib as shown. Do NOT use any tool which may damage Skin Plate surface.

NOTE: Reference outside Rib Installation for other notes and recommendations.

ALTERNATE RIB INSTALLATION

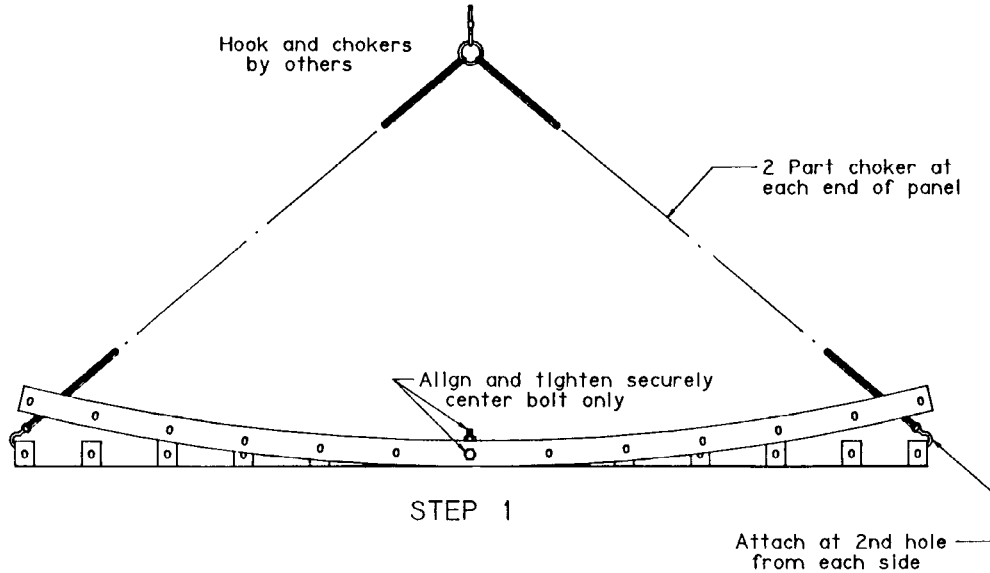

NOTE: This method is suggested for radii less than 10'-0"

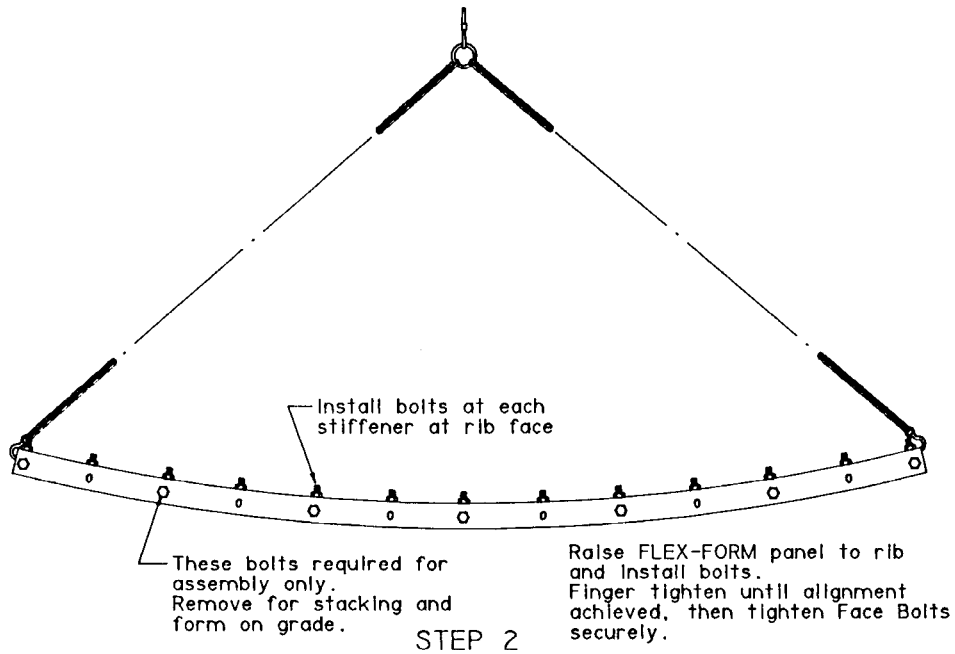

F. Void Panel

1. Flex-Form Void Panels are available in 3' x 4', 3' x 8', and 3' x 12' panels and are intended for use on walls with secondary pour troughs or haunches. They are designed to be used with 1/2" plywood which is attached by the contractor.
2. The Void Panel consists of typical Flex-Form stiffeners welded to a 4" strip of 3/16" steel skin plate at the top and 8" skin plate with accompanying tie holes at the bottom, thus creating a 24" void between these skin plate sections. A 5/16" spacer flat is welded between stiffener and skin plate so that 1/2" plywood will "flush up" to skin plate.

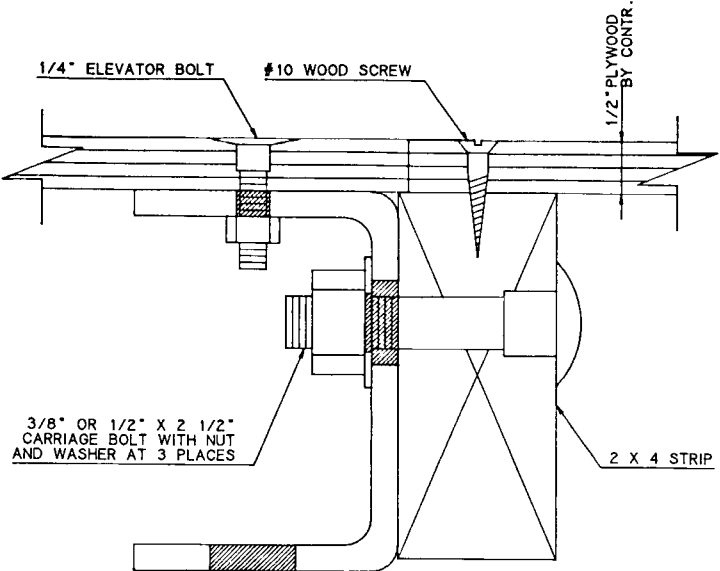

VOID PANEL
SUGGESTED PLYWOOD SPLICE

3. The preferred plywood fastener is 1/4" elevator bolts and nuts although wood screws may be used on panels with minimum re-use. See figure on next page for panel details. Plywood splices can be accommodated by lagging a 2 x 4 strip to web/accessory holes in stiffener. See figure above.

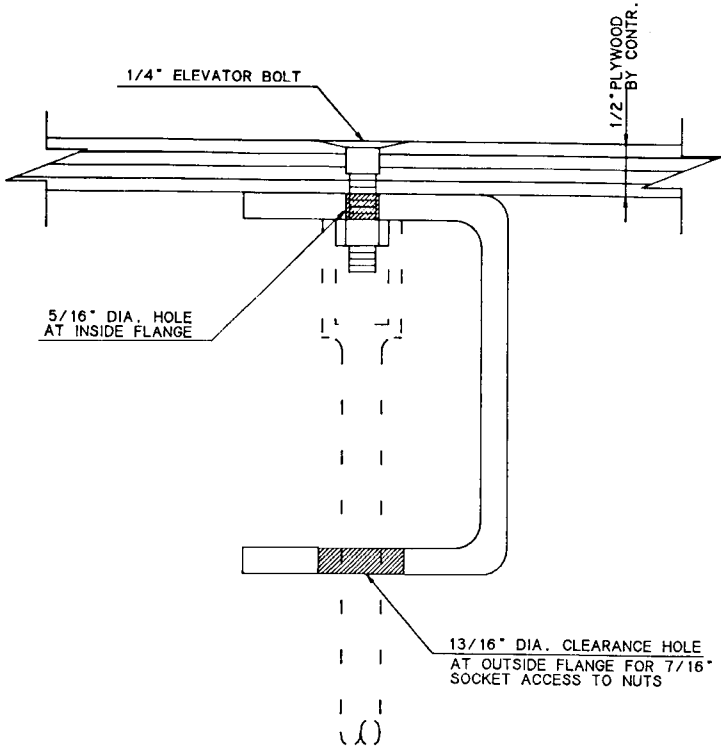

VOID PANEL
SUGGESTED PLYWOOD ATTACHMENT

3'-0" VOID PANEL SECTIONS

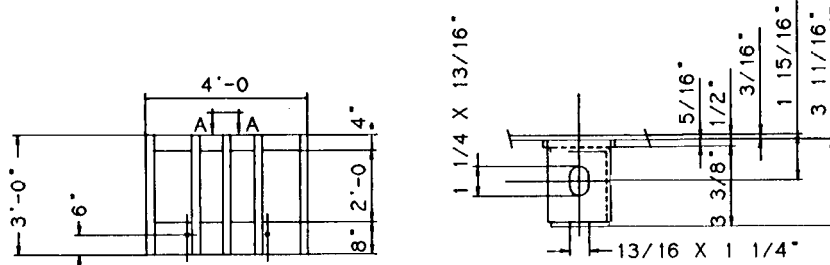

PC 32113 (3 X 4) Wt. = 129 Lbs. VIEW A-A

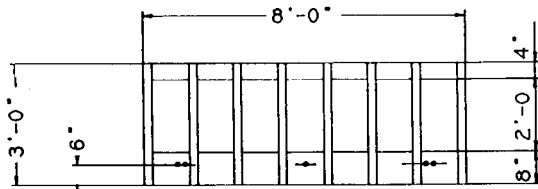

PC 32114 (3 X 8) Wt. = 214 Lbs.

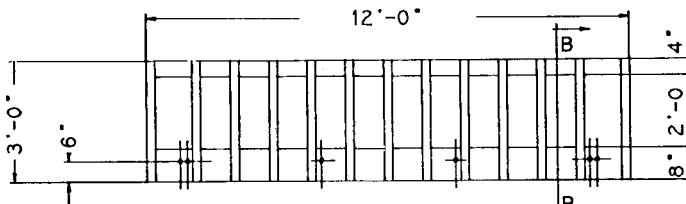

PC 32115 (3 X 12) Wt. = 335 Lbs.

NOTE: Tie hole locations same as typical 3' panel sections.

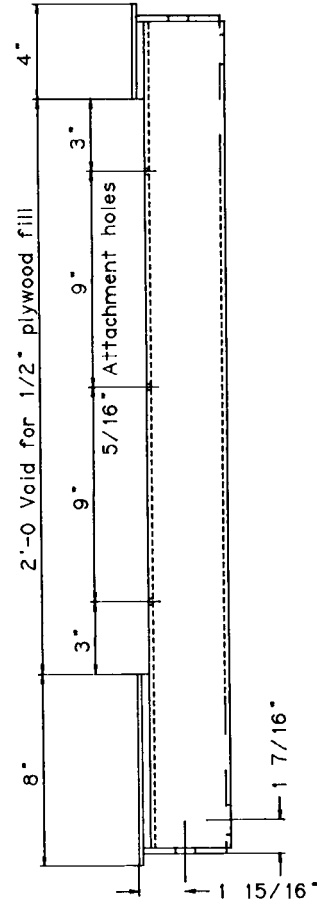

SECTION B-B

- The void from allows the contractor to drill holes as necessary for passage of reinforcing steel or provides for attaching wood-keyway using the Richmond Dowel Bar substitute system. See figure below.

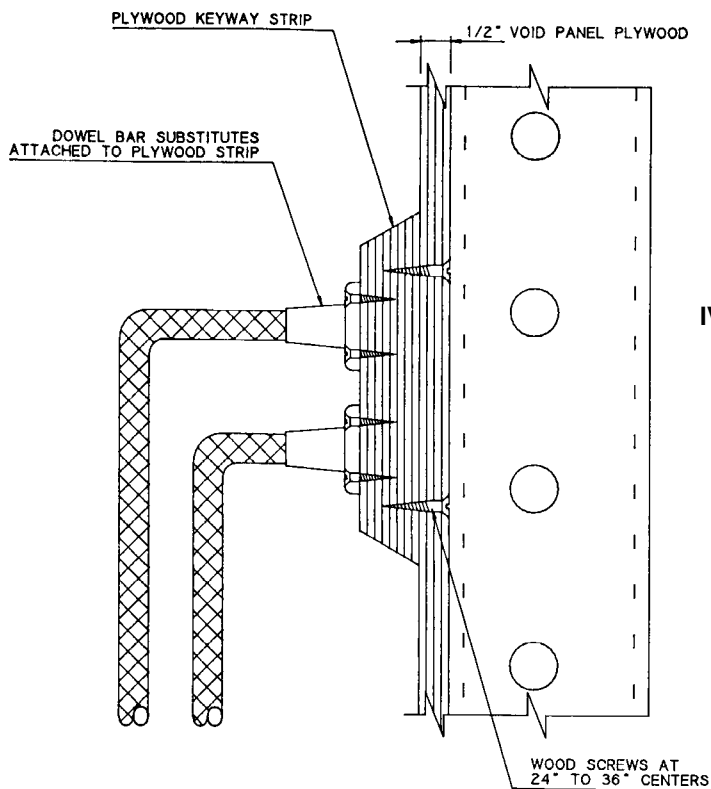

SUGGESTED BLOCKOUT DETAIL

G. Pour Door Panel

On occasion the requirement for pour windows or inspection doors arises. To meet this requirement a 6' x 12' Flex-Form® Panel is provided with two 20" x 24" hinged doors. These doors are located at the center of the 6'-0" width and 3'-0" from each end of the 12'-0" length so that when panels are stacked and placed side by side the resulting door spacing is 6'-0" horizontally and vertically. Generally doors are required on structures which have tall pours and a large radius (50'-0" +). This panel is dimensionally equal to a standard 6' x 12' and should be opposed with a standard 6' x 12'. The door panel is rentable and as depicted in Section I; the Product Code is 32117. The Pour Door is fabricated to a flat contour and therefore does not flex to an exact radius. However, the resulting deviation is generally within acceptable finish requirements for radii above 50'-0".

IV. ACCESSORY INSTALLATION

A. Tie Bearing Bracket

- Tie Bearing Brackets are attached to installed rib bolts. Remove nuts from two bolts at tie hole location and install tie bearing bracket then reinstall and tighten nuts.
- Outboard Tie Bearing Brackets should be held back slightly from edge of rib.
- Place Tie Bearing Bracket over stiffeners such that bearing pads on brackets bear directly on web of Flex-Form stiffener.
- Attach Tie Bracket Angle.

B. Top Tie/Lift Bracket

- Top Tie/Lift Bracket must be installed directly in line with stiffener. Use installed bolt and nut at rib face and install bolt and nut thru top of rib/stiffener.
- It is permissible to use single bolt connection at top when lifting individual panels only.

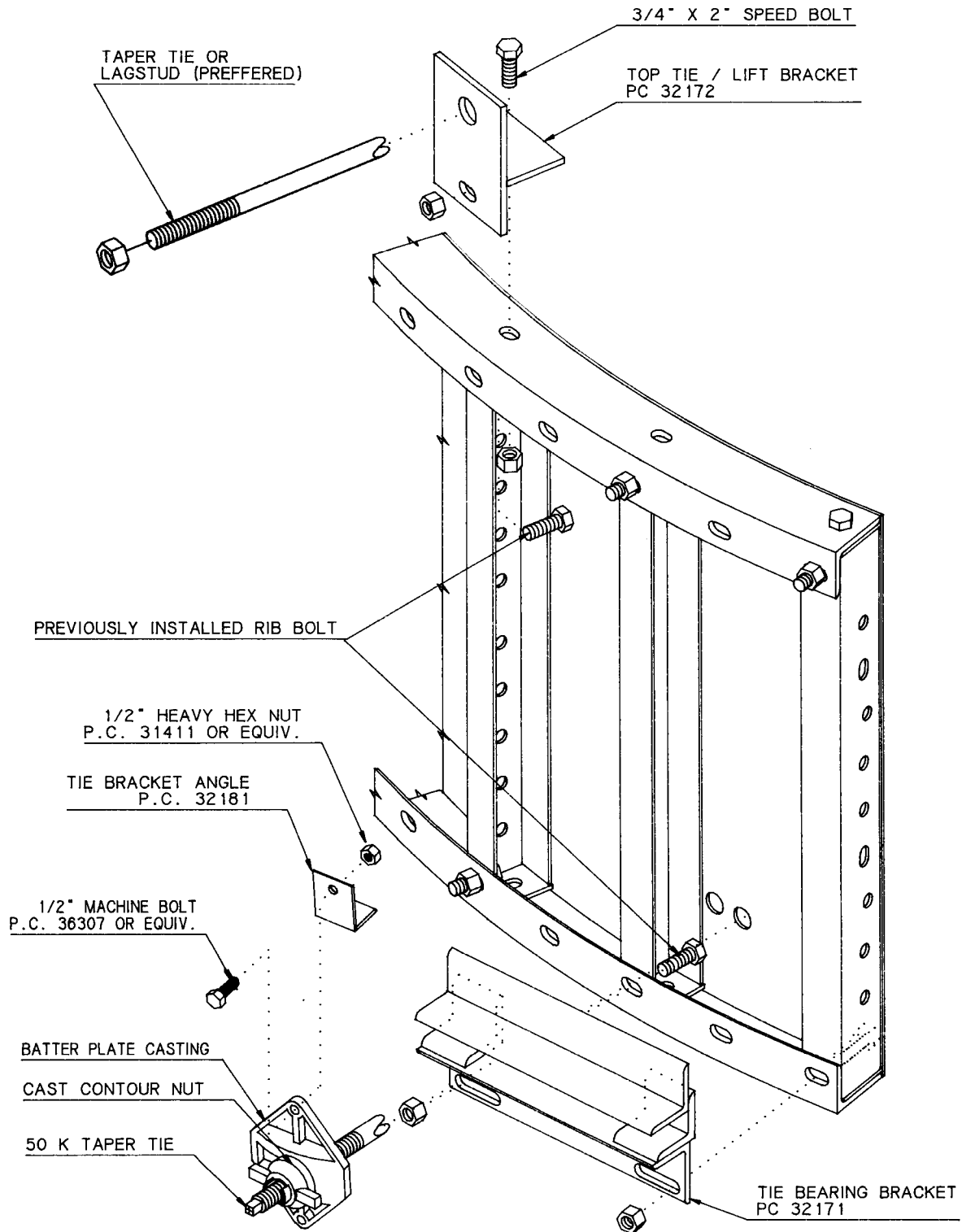

C. Panel Aligner Plate

- 1. Install Panel Aligner Plates at locations between Tie Bearing Brackets. Five (5) per 12'-0" panel, four (4) per 8'-0" panel, two (2) per 4'-0" panel. Install and tighten Aligner Plates before tightening horizontal joint bolts.

D. Plywood Extension/ Alignment Bracket

- 1. When pour height exceeds panel height by 6" or less the Plywood Extension/Alignment Bracket may be used to extend form height. This is one function of this accessory.

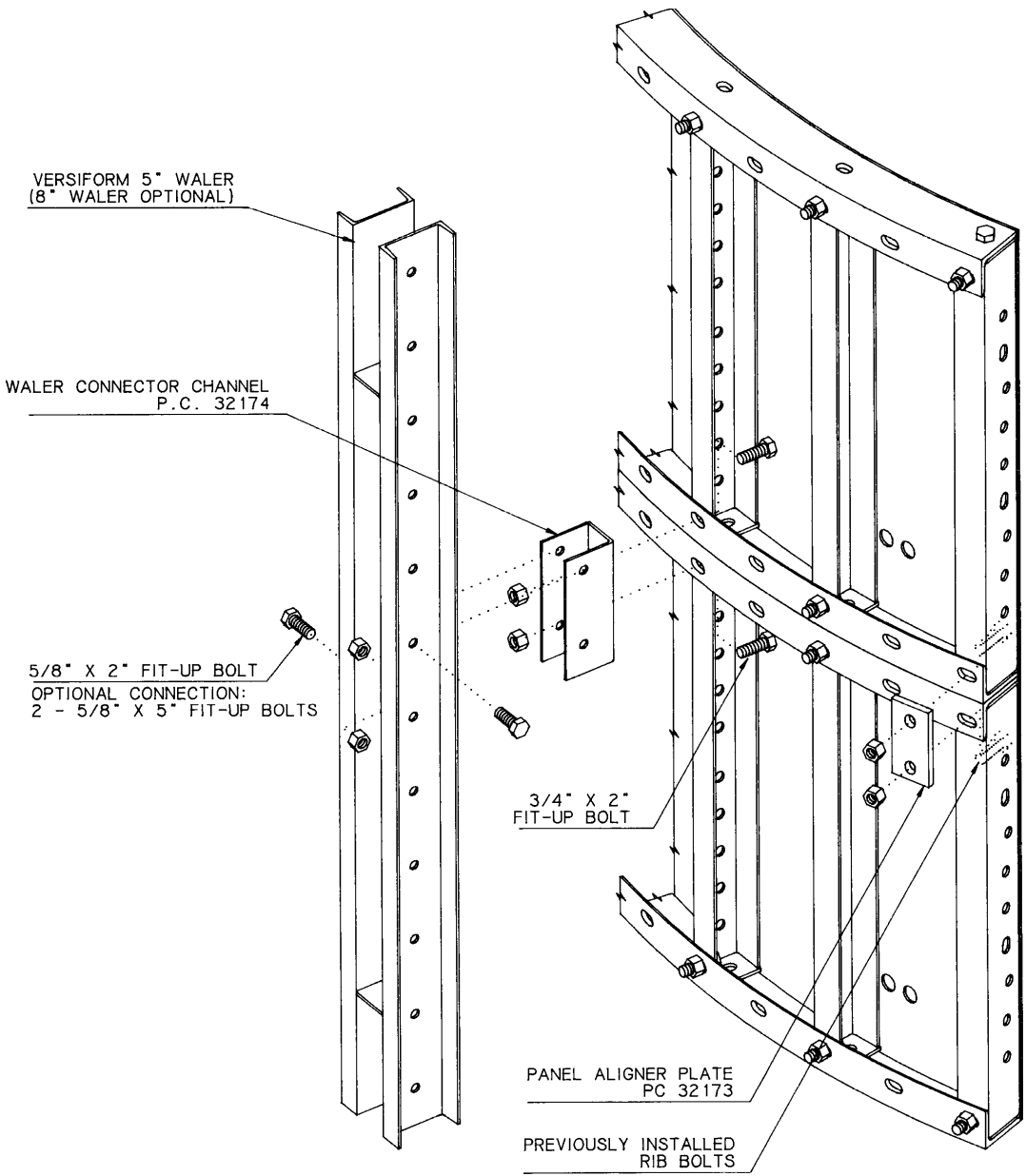

- The Plywood Extension/Alignment Bracket is designed for use with 1/2" plywood which can be fastened at either of two 5/16" dia holes provided on one leg or this bent plate angle member. Preferred fastener is the 1/4" dia. elevator bolt x 3/4" or 1" long with 1/4" nut. However, a #10 or 1/4" lag or wood screw could be used at larger radius requirements. See figure below.
- Nominal spacing is 12" centers, however, if top tie is required this spacing would inter-

ferre with locating Top Tie/Lift Brackets. For most radii 24" centers or every other stiffener is probably adequate. This problem can be circumvented by using a 5'-0 or 6'-0 panel at the top of the gang thereby placing ties below the top of the pour (wet tie at 12" max from top - 6" from top of panel).

- The alignment feature of this accessory is discussed in detail in gang assembly (Sect. III-C). Its function in this case is to align and anchor the bottom of form gangs to slab.

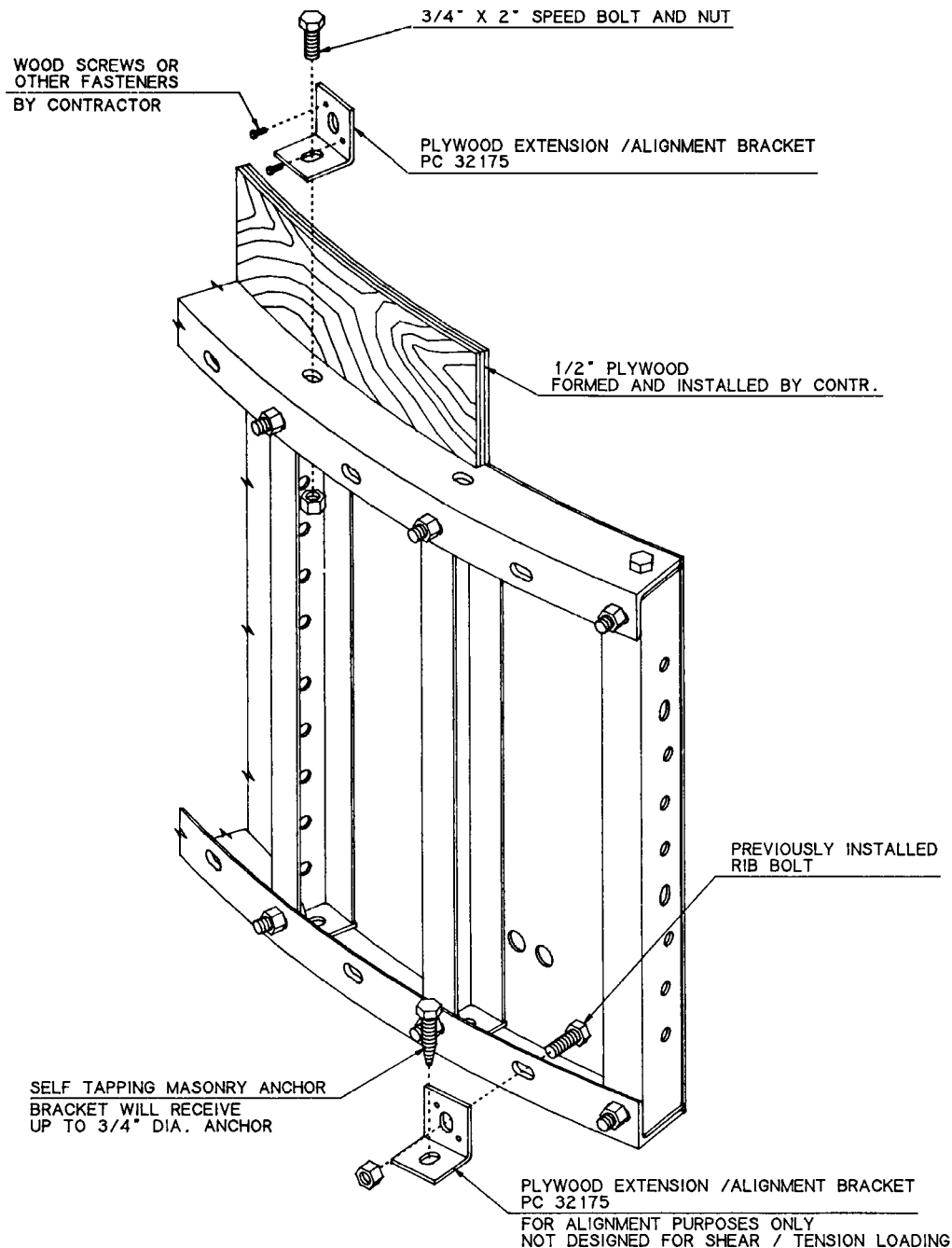

E. Ladder Connector Bracket

The Ladder Connector Bracket, PC32177, facilitates the addition of the Circular Column Form Ladders to a Flex-Form gang. The bracket will allow connection to an individual panel or can span two panels if desired. Two brackets are required for the connection of each ladder. See illustration below.

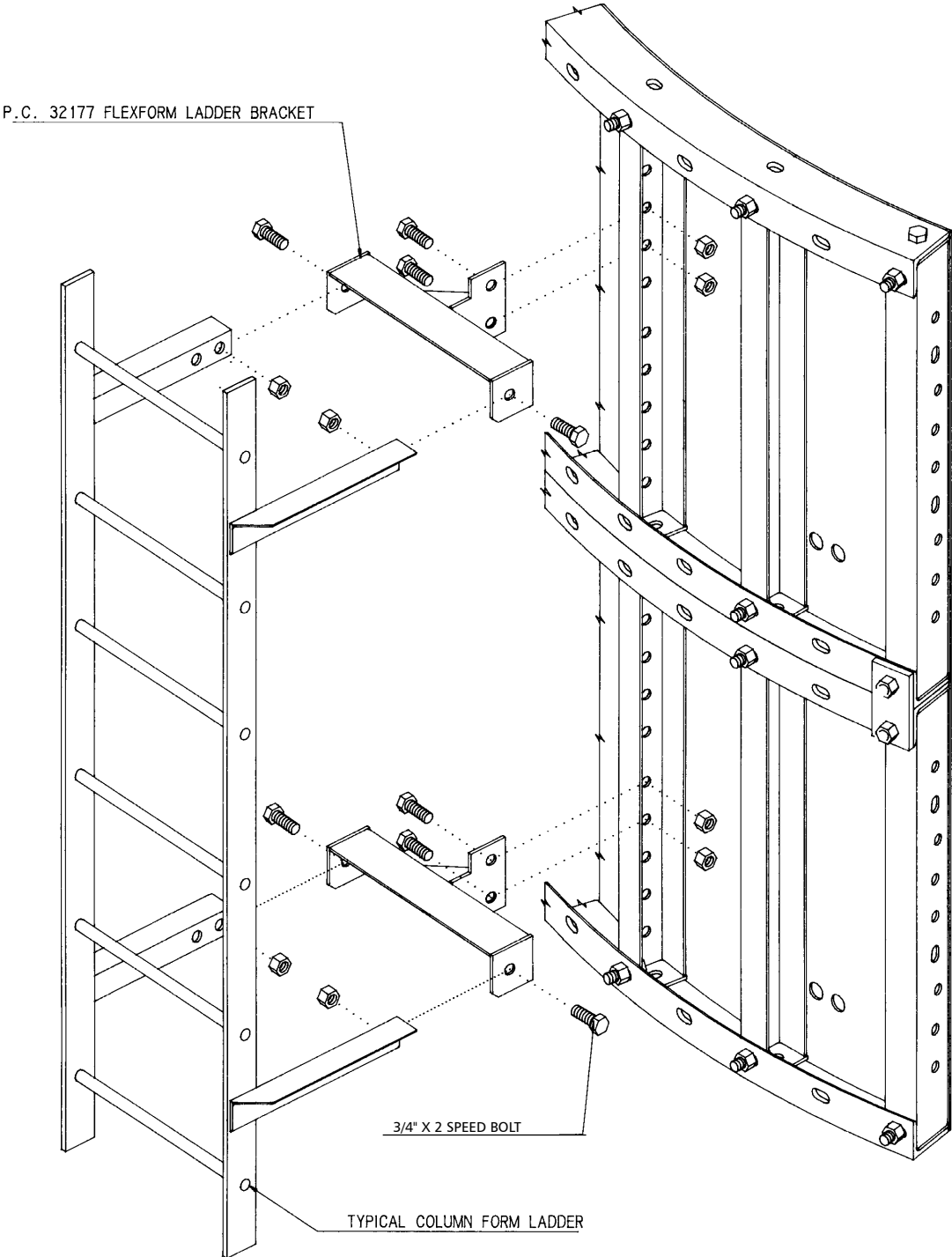

F. Walers

1. The Waler Connector Channel is used to provide a connection between Flex-Form panels and Versiform 5" walers. 5" Versiform walers are required on any Flex-Form gang in excess of 20'-0" high.
2. The Waler Connector Channel is attached to panels at each horizontal joint with existing bolts in the rolled rib. This is a two-bolt connection utilizing $\frac{3}{4}$ " dia. speed bolts. Top and bottom of gang attachment is a single $\frac{3}{4}$ " bolt connection. See figure on previous page.
3. The connection to the waler requires the Versiform $\frac{5}{8}$ " dia. bolts. This also is a two-bolt connection and can be accomplished in one of two ways as follows:
 - a. Use two (2) $\frac{5}{8}$ " x 5" bolts thru waler and bracket. See Figure on previous page.
 - b. Use two (2) $\frac{5}{8}$ " x 2" bolts. Install one bolt thru waler and one thru side of bracket at upper hole location and install one bolt thru waler and opposite side bracket at lower hole location. See figure on previous page.
4. Spacing of 5" walers are generally two (2) per 12'-0" panel, one (1) per 8'-0" panel and one (1) per 4'-0" panel or approximately 8'-0" centers. If Walkway Brackets are to be attached to walers the 8'-0" centers must not be exceeded.
5. The Waler Connector Channels are designed for use with new style Versiform walers (spacer plate at 11" from each end). Avoid using old style walers with plates $\frac{1}{4}$ " from each end.
6. Standard 5" Versiform walers are double 5" steel channels that are welded together through integral plate gussets which space them back-to-back 3" apart. Walers function to align and stiffen the gang form vertically. 5" walers are available in six standard lengths.
7. Standard 8" Versiform walers are double 8" channels welded together through integral plate gussets which also space them 3" apart. The function of 8" walers is similar to 5" walers, but they add significantly to the weight and cost of the gang. Though not commonly used with Flex-Form, they may be required for use as a plumbing waler. 8" walers are available in five standard lengths.

G. Anchor Clamp Adaptor — Multi-Lift Pours

1. The Anchor Camp Adaptor is designed for use with the Max-A-Form Thrust Bolt. It is a device with which to force the Flex-Form gang against the previously poured lift. Two (2) $\frac{3}{4}$ " x 2" Speed Bolts are required for connection to the top of the anchor clamp and two (2) $\frac{3}{4}$ " x 2" Speed Bolts are required to fasten the Thrust Bolt. See figure on following page.
2. The factors influencing anchor spacing are gang weight, spacing and anchor capacity. Ideally, spacing can be set to line up with a panel tie hole so that the tie hole can be used as an anchor template. To accomplish this a 5'-0" or 6'-0" panel must be used at the top of the form gang (5'-0" and 6'-0" wide panels have tie holes on both sides).
3. Anchor clamps incorporate a threaded rod looped around the anchor to provide vertical adjustment of form gangs, to effect horizontal adjustment of form gangs it is necessary to employ bracing or plumbing walers or a combination of the two.
4. Plumbing walers can be 5" or 8" Versiform walers. Symons Technical Services will determine waler size and spacing based on gang size and loading conditions. Since plumbing walers require an anchor or re-anchor it is economically feasible to place walers over tie holes. Though not necessary, this method eliminates the quantity of anchors needed and reduces the quantity of Tie Bearing Brackets since ties of normal locations will pass thru the walers. It does, however, necessitate two different tie or She Bolt lengths because the Waler is now acting as the Tie Bearing Bracket. $\frac{13}{16}$ " slots are provided in the face of the Rolled Angle Rib in line with the outboard Tie Holes on the 12'-0" and 16'-0" panels to allow for connection on the Panel Waler Connector.
5. If plumbing braces are to resist wind load, then it is recommended to have walers on both inside and outside gangs. If wind bracing is employed then plumbing can be accomplished with walers on only one side. See figures on following pages for attachment of Pipe Form Aligner or Max-A-Brace.

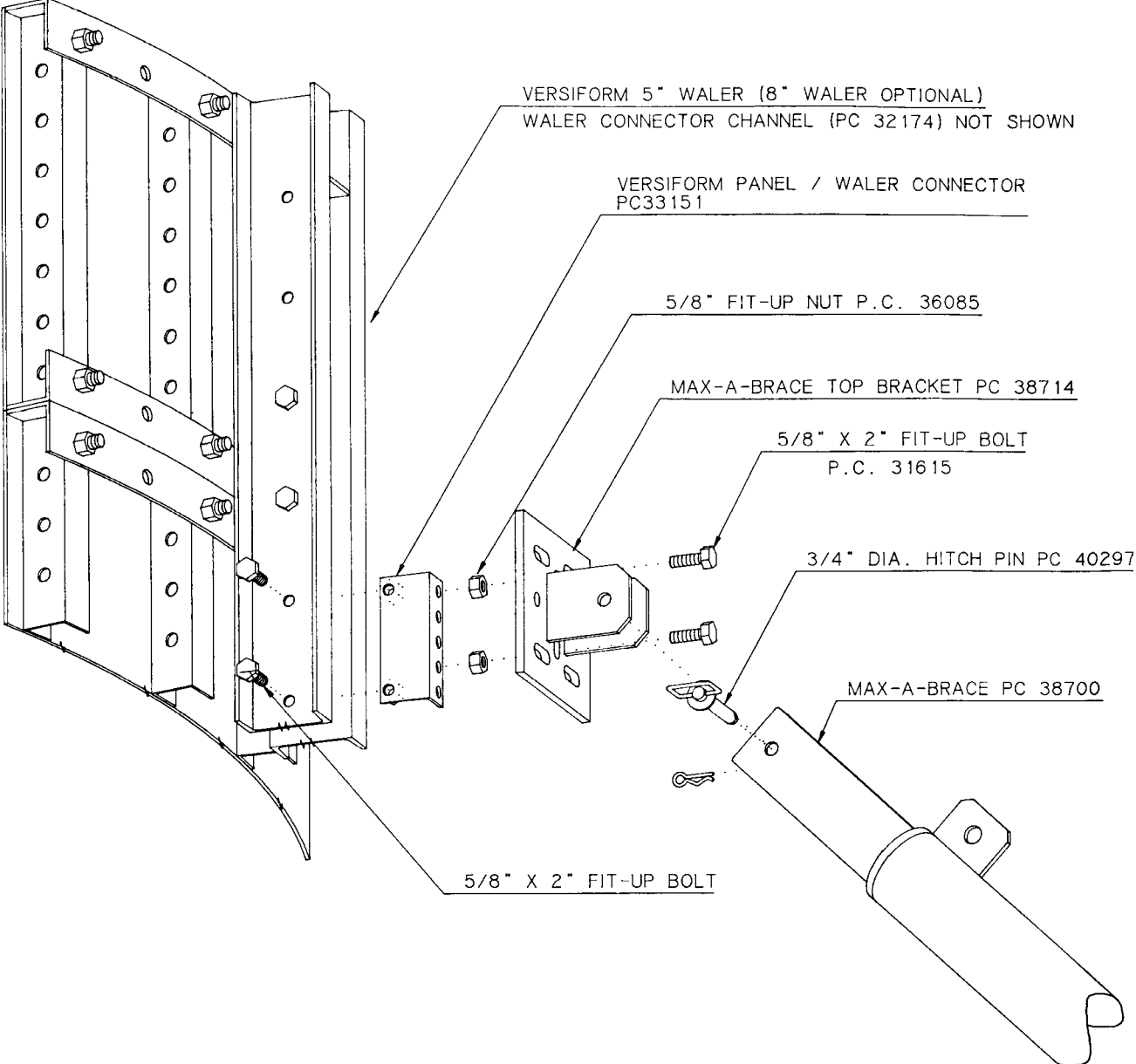

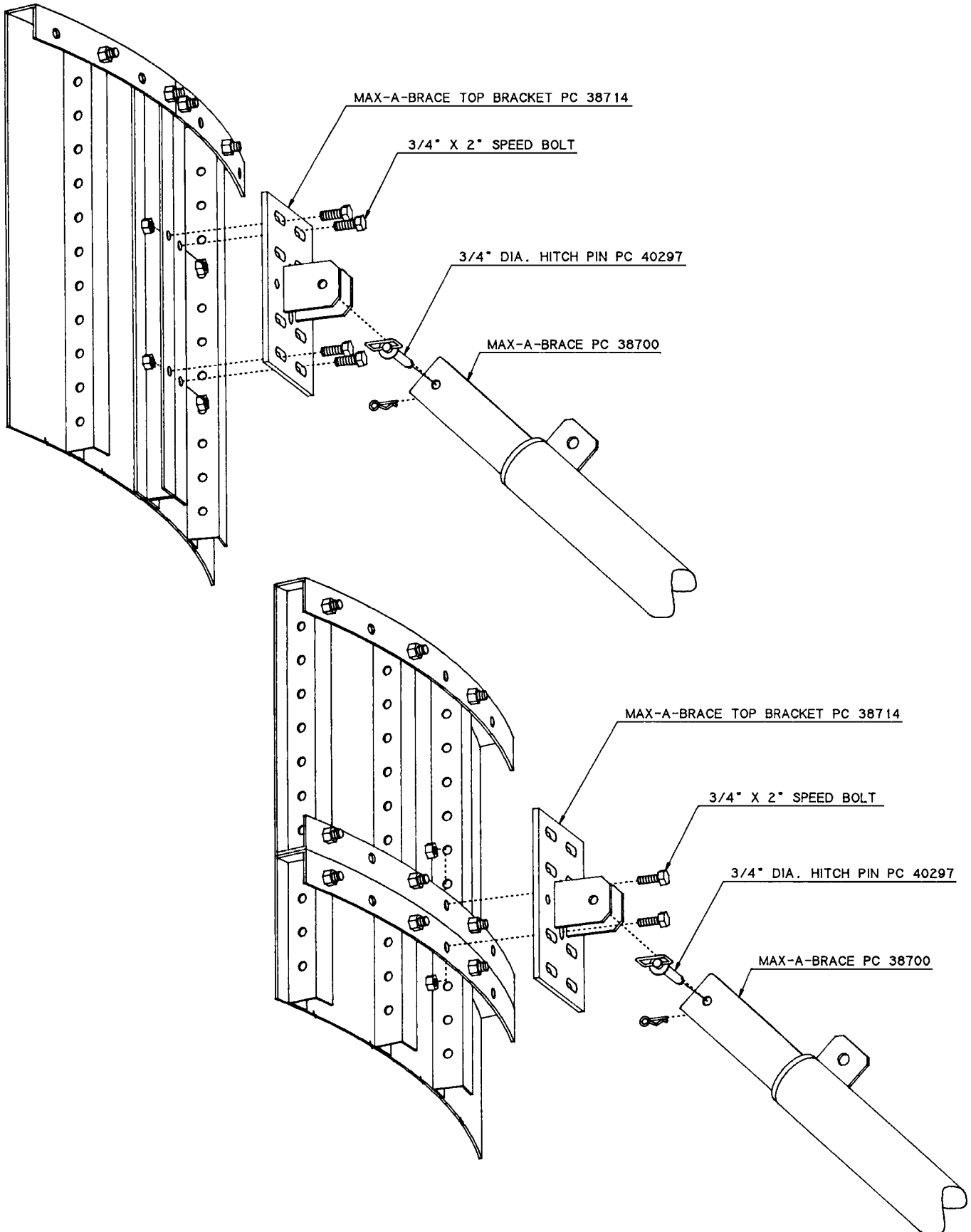

H. Walkway Brackets

- 1. The preferred walkway bracket for the Flex-Form system is the Max-A-Form Alternate Walkway Bracket PC38062 and Guardrail Post PC38061 which is attached to the accessory holes of the stiffeners. Two (2) 3/4" x 2" Speed Bolts are required for connection to stiffeners and two (2) 3/4" x 2" Speed Bolts for connection of Guardrail Post.

Note: Due to accessory hole spacing, use of the Versiform Wide Walkway Bracket is not recommended. Exception: Versiform Wide Walkway Bracket can be attached to walers.

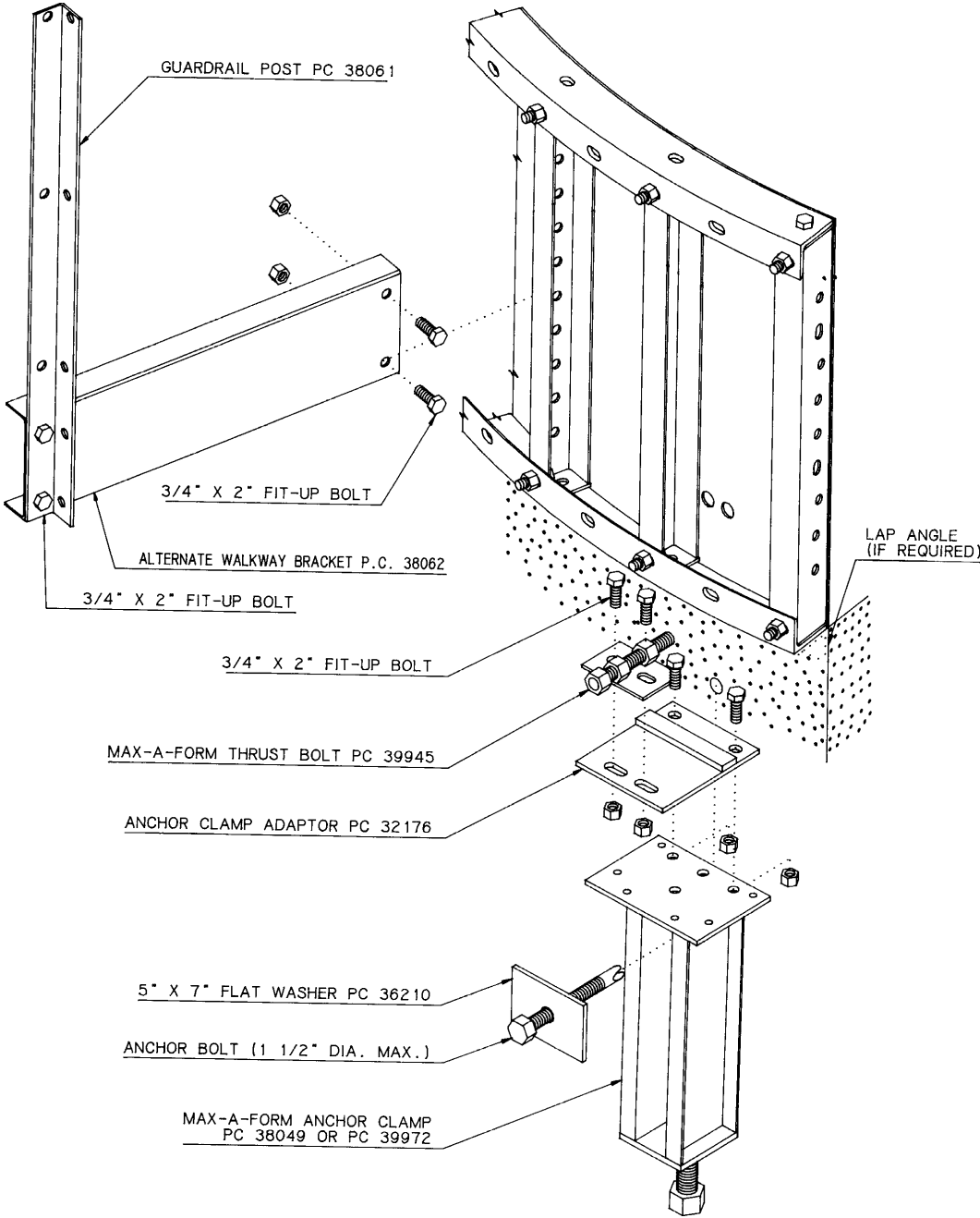

I. Wall Ties

1. Installation

- a. Wall ties must be in compliance with industry standards and safe practices established by the American Concrete Institute, The Occupational Safety and Health Administration, and The Scaffolding, Shoring and Forming Institute. The following note applies to all wall-tie applications. A 2.0 to 1.0 Safety Factor is required for all formwork.

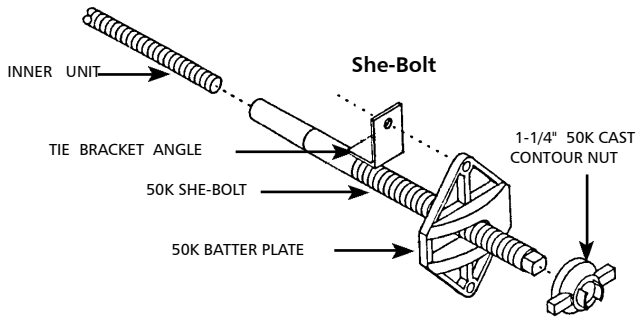

NOTE: THE BATTER PLATE CASTING FACILITATES A TIE SWING UP TO A 16 DEGREE ARC

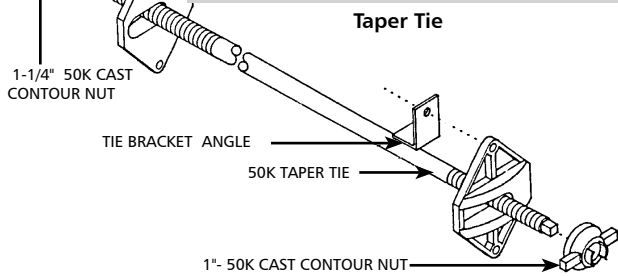

- b. Symons project drawings indicate safe load capacities of Taper Ties and She-Bolt assemblies, when both outer unit and inner ties are supplied by Symons.
- c. It is the contractor's responsibility to control concrete mix and placement procedure to assure that the maximum formwork design pressure is not exceeded.
- d. Tie installation precautions -- Be sure that the correct thread size cast contour nut is mated to all Taper Tie or She-Bolt out-unit threads.

2. Initial Impact Release of Embedded Taper Ties

- a. Taper Tie Hammering Caps are available for the smaller 1" diameter end of the 50K Taper Tie.
- b. The correct diameter and thread-type Hammering Cap must be utilized during initial impact release of embedded Taper Ties.
- c. The Hammering Cap is positioned at the smaller diameter end of the taper tie. The protruding end of the Hammering Cap is then struck with an 8 lb. or heavier sledge hammer. All mushrooming type impact damage is accumulated at the end of the Hammering Cap, rather than the butt end of the Taper Tie so as not to damage tie threads.

SHE-BOLT CAPACITIES AND THREAD DIMENSIONS

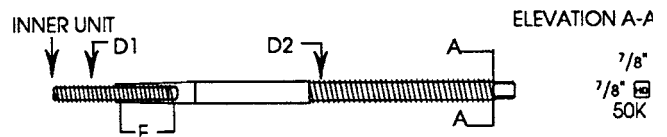

DESIGNATION	D1	D2	ULTIMATE STRENGTH	SAFE LOAD CAPACITY AT 2 TO 1 SAFETY FACTOR
50K	7/8"	1-1/4"	50,000 LBS.	25,000 LBS.

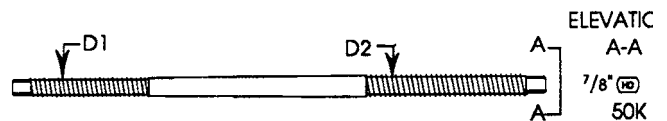

DESIGNATION	D1	D2	ULTIMATE STRENGTH	SAFE LOAD CAPACITY AT 2 TO 1 SAFETY FACTOR
50K	7/8"	1-1/4"	50,000 LBS.	25,000 LBS.

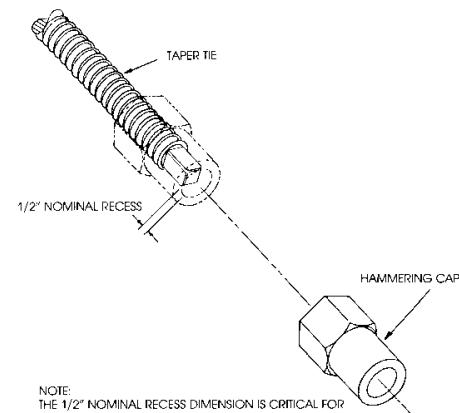

NOTE:
THE 1/2" NOMINAL RECESS DIMENSION IS CRITICAL FOR THE FOLLOWING 2 REASONS:
 • IT ASSURES THAT ALL OF THE THREADS OF THE NUT PORTION OF THE HAMMERING CAP ARE IN MESH TO WITHSTAND THE TRANSFER OF SLEDGE-HAMMER IMPACT TO THE TAPER TIE.
 • IT PROVIDES A SAFE CLEARANCE BETWEEN THE BUTT END OF THE TAPER TIE AND THE STRIKING SLEDGE-HAMMER.

VI. SPECIAL APPLICATIONS

Flex-Form can be adapted to many circular structures with the addition of certain special, purchase only components. The preceding text dealt primarily with round tanks and circular walls in ganged wall panel segments. This section will briefly cover some special applications and although some non-standard pieces and special techniques are necessary, the same basic assembly and erection procedures previously covered still apply. In all cases, special non-standard components are required. The extent or type of component required is dependent on the size of the individual structure and pertinent job conditions. Therefore, these applications should be discussed with Regional Engineer or Product Management.

A. Tension/Compression Ring

Commonly known as a shaft form this Flex-Form application has the distinct advantage of eliminating ties. The outside form becomes in effect a tension ring resisting tension forces, while the inside form (compression ring) resists compressive forces. Special items normally required are, closure panels, stripping panels, special ribs, tension/compression straps and stripping ratchets.

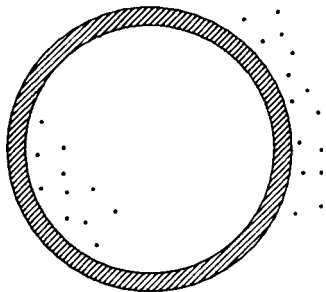

TENSION / COMPRESSION RING

B. Bullnose

Bullnoses are generally associated with highway piers and columns but the term may apply to the rounded end of any structure. The use of Flex-Form in this application is dependent on several conditions, the most important being the width and pour height of the structure. This application most often will require special closure panels only.

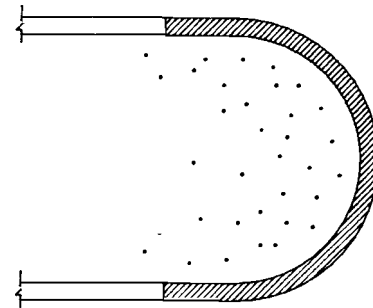

BULLNOSE

C. Pier Cap Radius Soffit

A very common detail on bridges is a radius soffit at the pier cap. Used in conjunction with the standard Max-A-Form panels, Flex-Form may be used to form the curved soffit of these structures provided the allowable loading on the panel itself is not exceeded. Most often the soffit panel will be fastened with bolts although the Max-A-Form adjustable jacks with bottom ties may be used for support.

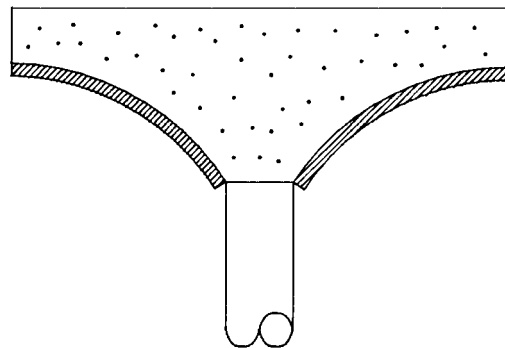

HAMMERHEAD CAP RADIUS SOFFIT

D. Ogee Curve

The Ogee Curve is a common contour seen at the top of the downstream face of a dam. Most often a parabolic curve, it is quite often close enough to a true radius to allow the use of a standard rolled rib. However, special rolled ribs may be manufactured to accommodate this situation.

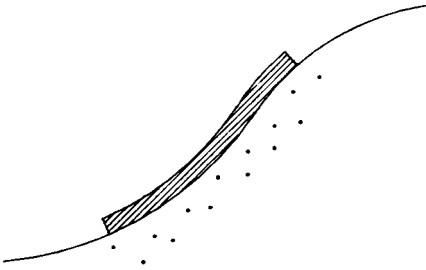

OGEE CURVE

E. Arch Culvert Radius Soffit

A typical condition used in the construction of ammunition igloos, Flex-Form can be incorporated with other standard or special equipment to form these structures.

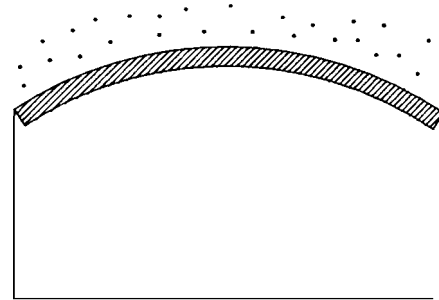

ARCH CULVERT RADIUS SOFFIT

INDEX

Accessories	7
Accessory Installation	17
Anchor Camp Adapter	7
Anchor Clamp Adaptor	22
Arch Culvert Radius Soffit.....	28
Batter Plate Casting.....	10
Batter Plate Castings	10
Bullnose	27
Concrete Pressure.....	1
Exterior Stiffeners.....	1
Fillers.....	6
Gang Assembly	7
Guardrail Post	25
Interior Stiffeners	1, 3
Ladder Connector Bracket	7, 21
Machine Bolt and Nut	10
Max-A-Form Aternate Walkway Bracket	25
Max-A-Form Thrust Bolt	22
Multi-Lift Pours.....	22
Ogee Curve	28
Panel Aligner Plate	7, 19
Panel End Rail Bolt Spacing	2
Pier Cap Radius Soffit.....	27
Plugs	10
Plywood Extension/ Alignment Bracket	19
Plywood Extention/Alignment Bracket.....	7
Pour Door Panel	17
Product Codes	1
Rib Field Installation.....	11
Rolled Ribs	3
She-Bolt.....	26
Stacking Panles	10
Standard 5" Versiform Walers.....	22
Standard 8" Versiform Walers.....	22
Standard Panels.....	1
Straight Ribs.....	5
Taper Tie.....	26
Taper Tie Hammering Caps.....	26
Taper Ties	10
Temporary Bracing	9
Tension/Compression Ring.....	27
Tie Bearing Bracket.....	7, 17
Tie Bracket Angle.....	7, 10
Top Tie/Lift Bracket	7, 17
Void Panel	15
Waler Connector Channel.....	7, 22
Walers	10, 22
Walkway Brackets.....	22, 25
Wall Ties.....	26

	<p style="text-align: center;">⚠ WARNING</p> <p style="text-align: center;">Improper Use of Concrete Accessories Can Cause Severe Injury or Death</p> <p>Read, understand and follow the information and instructions in this publication before using any of the Dayton Superior concrete accessories displayed herein. When in doubt about the proper use or installation of any Dayton Superior concrete accessory, immediately contact the nearest Dayton Superior Service Center or Technical Service Department for clarification. See back cover for your nearest location.</p>
---	--

Dayton Superior products are intended for use by trained, qualified and experienced workmen only. Misuse or lack of supervision and/or inspection can contribute to serious accidents or deaths. Any application other than those shown in this publication should be carefully tested before use.

The user of Dayton Superior products must evaluate the product application, determine the safe working load and control all field conditions to prevent applications of loads in excess of a product's safe working load. Safety factors shown in this publication are approximate minimum values. The data used to develop safe working loads for products displayed in this publication are a combination of actual testing and/or other industry sources. Recommended safe working loads given for the products in this publication must never be exceeded.

Worn Working Parts

For safety, concrete accessories must be properly used and maintained. Concrete accessories shown in this publication may be subject to wear, overloading, corrosion, deformation, intentional alteration and other factors that may affect the device's performance. All reusable accessories must be inspected regularly by the user to determine if they may be used at the rated safe working load or should be removed from service. The frequency of inspections depends upon factors such as (but not limited to) the amount of use, period of service and environment. It is the responsibility of the user to schedule accessory hardware inspections for wear and remove the hardware from service when wear is noted.

Shop or Field Modification

Welding can compromise a product's safe working load value and cause hazardous situations. Knowledge of materials, heat treating and welding procedures is necessary for proper welding. Consult a local welding supply dealer for assistance in determining required welding procedures.

Since Dayton Superior cannot control workmanship or conditions in which modifications are done, Dayton Superior cannot be responsible for any product altered in the field.

Interchangeability

Many concrete accessory products that Dayton Superior manufactures are designed as part of a system. Dayton Superior strongly discourages efforts to interchange products supplied by other manufacturers with components supplied by Dayton Superior. When used properly, and in accordance with published instructions, Dayton Superior products have proven to be among the best designed and safest in the industry. Used improperly or with incompatible components supplied by other manufacturers, Dayton Superior products or systems may be rendered unsafe.

Installation

WARNING

1. Dayton Superior Corporation products shall be installed and used only as indicated on the Dayton Superior Corporation installation guidelines and training materials.
2. Dayton Superior Corporation products must never be used for a purpose other than the purpose for which they were designed or in a manner that exceeds specific load ratings.
3. All instructions are to be completely followed to ensure proper and safe installation and performance.
4. Any improper misuse, misapplication, installation, or other failure to follow Dayton Superior Corporation's instruction may cause product malfunction, property damage, serious bodily injury and death.

THE CUSTOMER IS RESPONSIBLE FOR THE FOLLOWING:

1. Conformance to all governing codes
2. Use of appropriate industry standard hardware
3. The integrity of structures to which the products are attached, including their capability to safely accept the loads imposed, as evaluated by a qualified engineer.

SAFETY INSTRUCTIONS:

All governing codes and regulations and those required by the job site must be observed. Always use appropriate safety equipment

Design Changes

Dayton Superior reserves the right to change product designs, rated loads and product dimensions at any time without prior notice.

Note: See Safety Notes and Safety Factor Information.

DAYTONSUPERIORBRANDS

CONCRETEACCESSORIES

Accubrace[®]
Aztec[®]
Bar Lock[®]
Corewall[®]
Fleet-Lift™
Swift Lift[®]
Taper-Lock[®]

CONSTRUCTIONCHEMICALS

Unitex[®]

FORMINGPRODUCTS

Symons[®]
Max-A-Form[®]
Steel-Ply[®]
Sym-Ply[®]

DAYTONSUPERIORPRODUCTS

BRIDGE DECK FORMING

Adjustable Joist Hangers
Bridge Overhang Brackets
Haunch and Fillet Forming
Pres-Steel, Coil Rod and Con-Beam
Hangers
Screed Supports

CHEMICALS

Bond Breakers
Cleaners / Strippers
Concrete Repair/Restoration
Curing Compounds / Sealers
Epoxies
Floor Levelers
Form Release Agents
Grout
Hardeners / Industrial Toppings
Liquid Densifiers
Surface Retarders

FORMINGANDSHORING

Aluminum Shoring
Ganged Formwork
Garage Beam System
Handset Formwork
Highway Forms
Jump Forms
Modular Deck Shoring
One Sided Frames
Self Spanning Forms
Steel Frame Shoring

FORMLINERS

ABS Plastic
Polystyrene Plastic

PAVING

Dowel Bar Expansion Caps
Dowel Bar Retrofit System
Elastomeric and Hot Pour Joint Seal
Metal Keyway Form Systems
Tie Bar Assemblies
Transverse Bar Assemblies
Welded Dowel Assemblies
Wire Baskets without Dowels

PRECAST

Anchors and Lift Systems
Coil / Ferrule Inserts
Core Plugs
Magnets
Precast Forms

Sandwich Panel Connector
Shear Connectors
Slotted Inserts

REBAR SPLICING

Forged Dowel Bar Couplers
Lockshear Bolt Couplers
Shear Resistance Products
Straight Thread Couplers
Taper Thread Couplers

REBAR SUPPORTS

Concrete Dobies
Continuous Plastic and Steel
Bar Supports
Individual Plastic and Steel
Bar Supports
Mesh Chairs
Paving Chairs
Side Form Spacers

TIES AND ACCESSORIES

Modular Form Ties
Single Waler System
Ties and Accessories

TILT-UP

Braces and Brace Anchors
Helical Ground Anchors
Setting Plugs
Strongback System
Tilt-Up Anchors and Lifting Systems

CONTACT INFORMATION



48575 Downing Street
Wixom, MI 48393
800.876.4857 | info@formtechinc.com
formtechinc.com

99853
03/12

Give us a call at any of our branch locations, email us at info@formtechinc.com, or click on formtechinc.com/quote to get a quote. Our experienced Form Tech representatives will answer your questions, and help you get your project started with some of the best concrete forming, shoring, and accessory products in the industry, backed by a professional and detail-oriented staff.



Charleston, SC

7377 Peppermill Lane
North Charleston,
SC 29418
843.628.3434



Detroit, MI

Corporate Headquarters
975 Ladd Road
Walled Lake,
MI 48390
Branch: 248.344.8260
Corporate: 248.344.8265



Charleston, WV

161 Industrial Road
St. Albans,
WV 25177
304.722.6804



Pittsburgh, PA

2850-A Kramer Road
Gibsonia,
PA 15044
412.331.4500



Charlotte, NC

1000 Thomasboro Road
Charlotte,
NC 28208
704.395.9910



Raleigh, NC

115 Peffinder Lane
Raleigh,
NC 27603
919.833.0911



Cleveland, OH

20801 Miles Road
North Randall,
OH 44128
216.692.0497



TRUSTED FORMWORK & ACCESSORY SPECIALISTS

800-876-4857 | info@formtechinc.com | formtechinc.com