

**PERFORM
WITH
PRECISION**

STEEL-PLY®

**CONCRETE
FORMING
SYSTEM**

APPLICATION GUIDE

F FORMTECH
concrete forms, inc.



SYMONS®
By Dayton Superior



INNOVATION CENTER

REAL-WORLD SOLUTIONS INSPIRED BY YOUR VISION

Your vision is to take concrete construction to new heights. We turn that vision into real-world solutions through precision research and development, testing and technology.

Together we are redefining what is possible in the concrete construction industry. Our Innovation Center is comprised of:

- **A state of the art chemical lab**
- **A full-featured mechanical test facility**
- **Product demonstration areas**
- **Contemporary training and meeting areas**

Bring us your ideas and we will deliver your solution.



800.876.4857

Table of Contents

Introduction	1	Adjustable Shear Wall Brackets	31
Handles	1	Anchor Inserts.....	31
Components	1	Anchor Bolts.....	31
Safety Eyes.....	1	Guide Bolts	31
Fillers	2	Multi-Shear Wall Brackets	32
Wedge Bolts.....	2	Conventional Panel Tie Gang Forming	33
Steel Fillers and Long Bolts	3	Assembling Gangs	33
Adjustable Long Bolts	3	Gang Form Ties.....	34
Job Built Fillers	4	Cone Ties.....	35
Stripping and Tie Breakbacks.....	4	Form Alignment.....	35
Ties	5	Tie Removal.....	35
Tie Capacities	5	Curved Walls.....	35
Tie Alignment	5	Curved Gang Forming.....	37
Tie Spacings.....	5	Horizontal Gang Alignment.....	38
Special Purpose Ties and Hardware	6	3" Aligner Channel / 3" Channel Aligner Bracket.....	39
Single End Threaded Ties	6	Vertical Strongbacks	39
Adjustable Single End Threaded Ties.....	6	Steel-Ply Gang Fillers	40
Ties Threaded Both Ends	6	Sizes	40
Single End Threaded Toggle Ties.....	7	Double Duty Lift Brackets.....	40
#1 Cone Ties	7	Waler.....	41
#2 Cone Ties	7	Turnbuckle	41
#2A Cone Ties.....	8	Double Duty Lift Bracket.....	41
S-Pilaster Ties	8	Scaffold Bracket	41
Base Tie Bolts	8	Ties	42
S-Base Ties.....	9	Horizontal Steel-Ply	42
Pre-Bent Ties.....	9	Horizontal Gang Assembly	43
Accessories	9	Walers.....	44
Pipe Walers.....	9	Waler Splice Channels	45
3" Aligner Channels/3" Channel Aligner Brackets	10	"Y" Walls with 45° Walers and Splices	46
Pilaster Forms and Short Bolts.....	10	Maxi-Waler Wall Gangs	49
Pilaster Braces.....	11	Assembly	49
Pilasters formed with Inside Corners	11	Spreader Clip.....	50
Bay Corners.....	12	Adjustable Top Tie.....	50
Bay Corner Brackets.....	12	Waler Lift Brackets.....	51
Hinged Corners	13	Ganged Core Forms	53
Culvert Forms.....	13	Double Hinged Fillers.....	53
Form Aligners.....	14	Lifting Core Forms	53
Turnbuckle Aligners	15	Double Hinged Filler	54
Pipe Form Aligners	15	Double Hinged Filler	56
Scaffold Brackets	16	Columns	58
Brick Ledge Brackets.....	16	Column Wedge Bolt Positions	58
Beam Pockets.....	16	Adjustable Column Form Extender	59
Form Extension Brackets	17	Column Filler Angle	59
Cantilever Brackets	17	Ganged Columns	59
Haunch Support Brackets.....	18	Quick Column Hardware.....	60
Handset Erection Procedures	20	Column Lift Corner (CLC).....	60
Sill Plates.....	20	Column Form.....	60
Footing Forming with Steel-Ply Panels	20	Adjustable Rectangular Column Form	61
Erection Procedures	22	Battered Walls	61
Sloped Footings.....	24	Batter Tie Down Bracket	62
Stepping Forms.....	24	Index	65
Bulkheads	25		
Wall Corners.....	25		
Intersecting Walls.....	26		
Walers.....	27		
Strongbacks.....	28		
Stacking Forms	29		
Second Lift Forming	30		

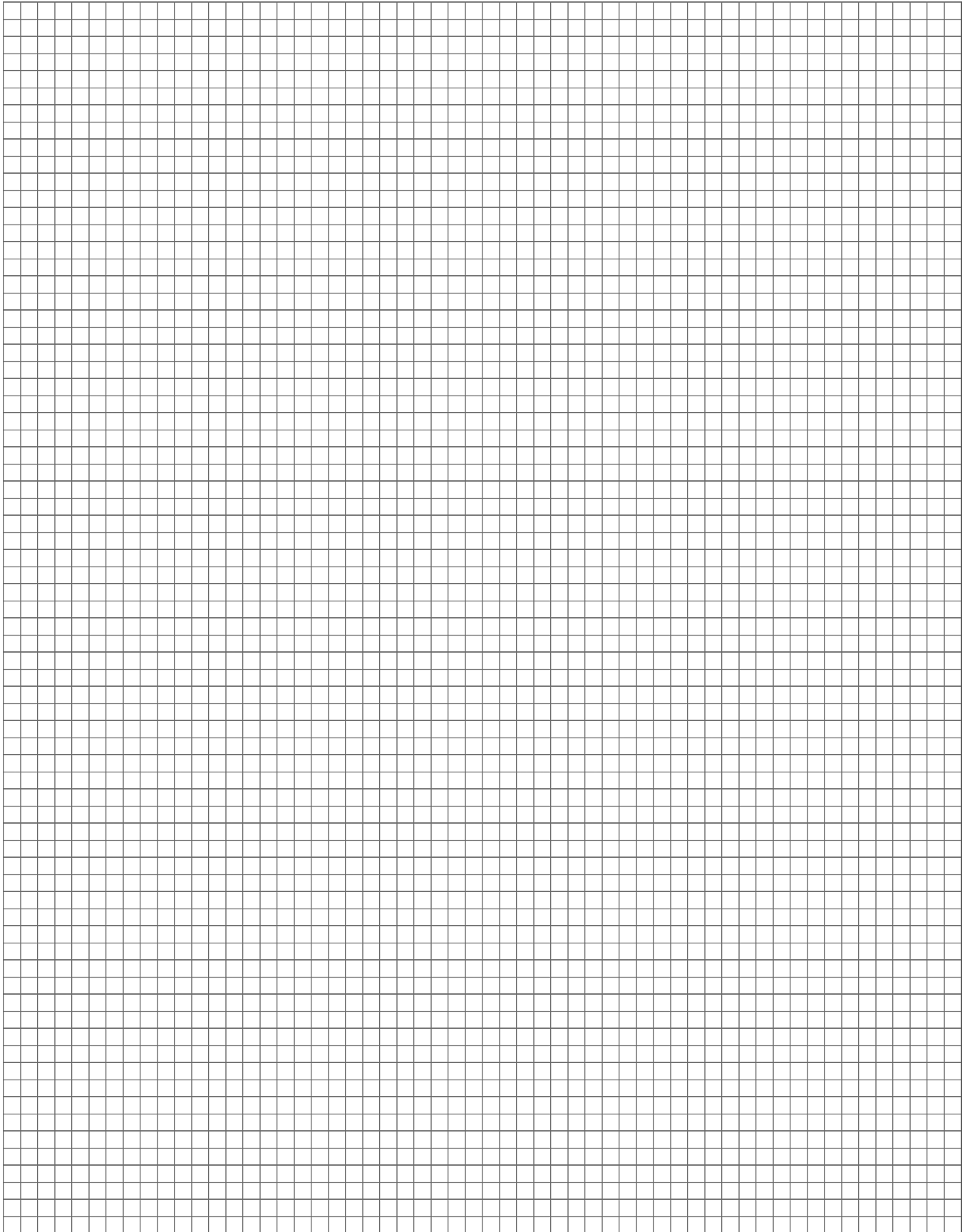

INTRODUCTION

The Steel-Ply components and accessories illustrated herein have been designed with safety and performance in mind to help achieve a safe and productive forming operation. It's recommended that all construction personnel thoroughly familiarize themselves and comply with the applicable industry standards and safe practices established by the American Concrete Institute (ACI), American National Standards Institute (ANSI), The Occupational Safety and Health Administration (OSHA), and the Scaffolding, Shoring and Forming Institute (SSFI). Tie spacings shown are for illustration purposes only. Proper spacing must be determined for individual job conditions. Refer to Ties section for tie capacities. The maximum allowable pour pressure for the Steel-Ply system is 1000 psf.

Handles

Steel-Ply standard handles are designed to be used to assist in manually transporting or positioning each modular panel, and should not be used as a means of attachment or for any other purpose.

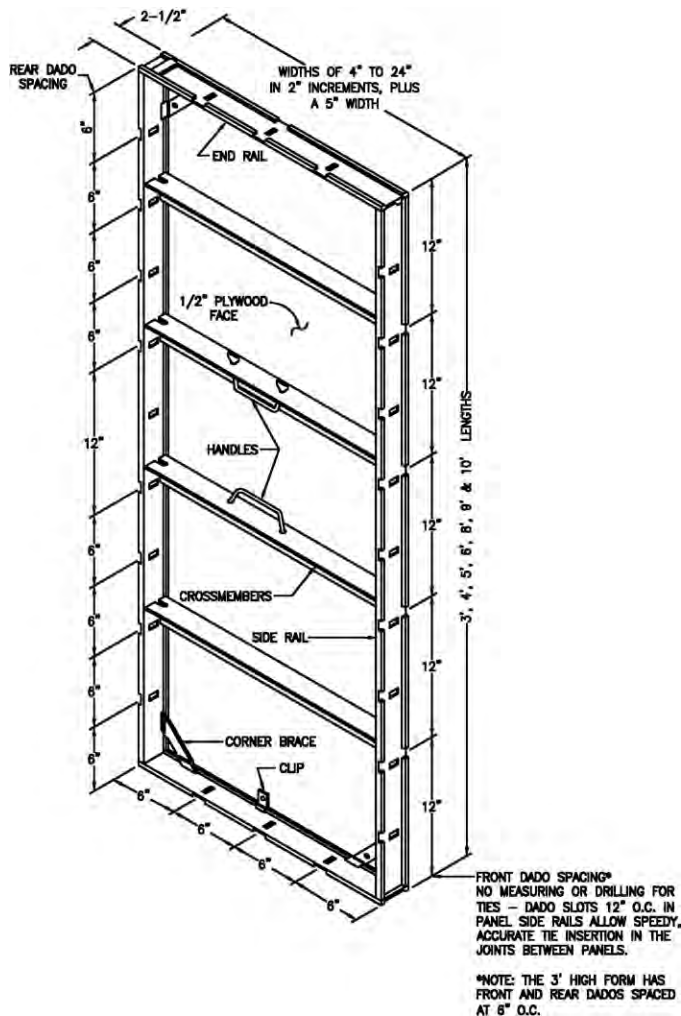

5' Steel-Ply Panel

COMPONENTS

Safety Eyes

The installation of Safety Eyes on Steel-Ply panels allows easy attachment of safety belts while working on the forms, though work platforms are recommended and normally provide more efficient working conditions.

The Safety Eye meets the requirements of OSHA (29 CFR Part 1926) subpart M 1926.502d15.

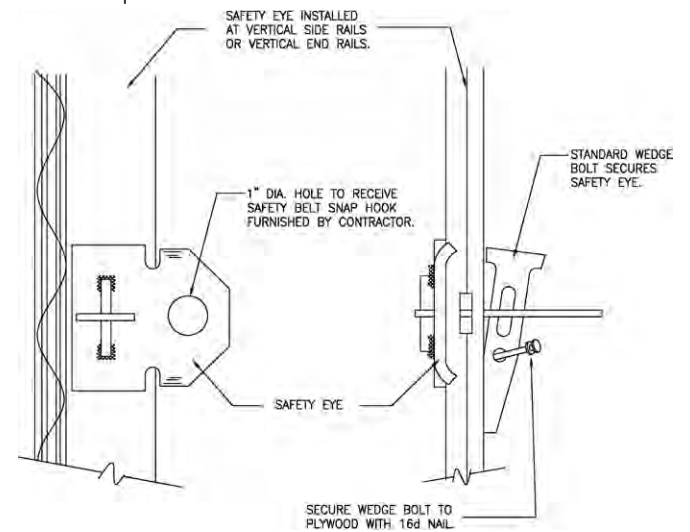

Safety Eye Installation

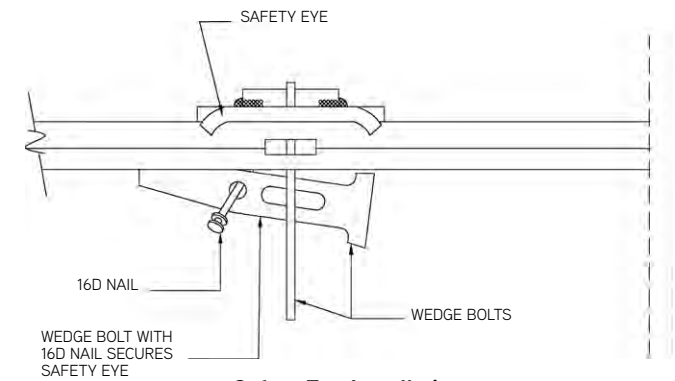

Safety Eye Installation

CAUTION: DO NOT use handles as a safety belt hook-up or as a connecting point for bracing, scaffolding or ganged movement of panels.

CAUTION: Do not use Safety Eye as a Lifting Bracket. Do not attach to a single horizontal side rail.

CAUTION: Symons recommends gloves, safety shoes and safety glasses during the panel erection and stripping processes.

Fillers

Steel-Ply Fillers are manufactured from the same steel and plywood as panels, and are available in all even inch widths from 4" to 22" and 5". These fillers require wall tie connections to both side rails, and therefore either the same size filler must be in position directly opposite or some specific form detail that will accept the wall tie connections.

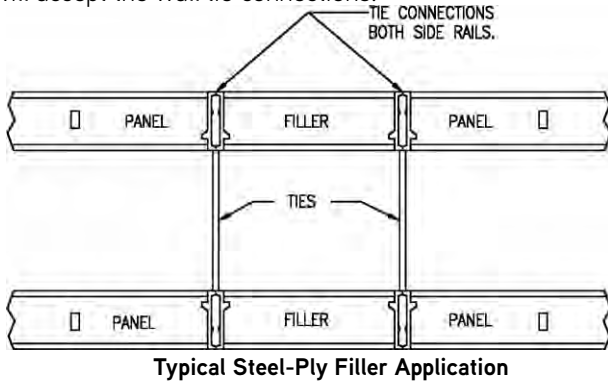

Typical Steel-Ply Filler Application

Filler width may be determined by looking carefully at the end rails. Slots are located in 6" increments from each end of the end rail for fillers from 10" to 22".

NOTES:

- Front and rear dados align on 12" centers. Three foot high forms have front and rear dados at 6" centers.
- Handles are added to 20", 22" and 24" wide frames. 5', 6' and 8' length frames have two handles. 3' and 4' lengths have one handle.
- There are no Wedge Bolt slots or dados on 4", 5", 6" and 8" filler end rails. All other end rails have slots and dados at 6" O.C. from both ends.

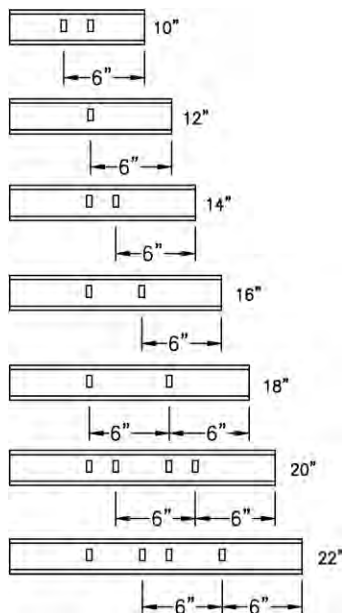

Slot Spacing for Filler End Rails

Wedge Bolts

Two identical Wedge Bolts function as a lock-bolt set, one as a connecting bolt, the other as a clamping wedge. At typical side rail to side rail form connections, the loop end of the tie is positioned in dado slots and is secured by the same Wedge Bolts.

For typical walls, form connecting Wedge Bolts are only required at standard tie connection positions. Additional Wedge Bolts are utilized at other positions for attachment of walers, scaffold brackets or other accessory components.

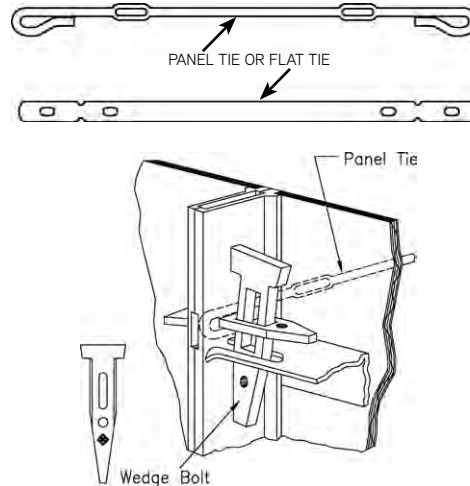

Typical Wedge Bolt Connection through Ties and Side Rails

A sufficiently tight Wedge Bolt connection can be achieved by pushing down on the head of the vertical Wedge Bolt with one hand while striking the head of the lateral Wedge Bolt with a hammer. The vertical Wedge Bolt will respond downward to a tight, secure position. Excessively tightened Wedge Bolts require excessive labor during stripping. Care should be taken when striking Wedge Bolts with a hammer during assembly and disassembly.

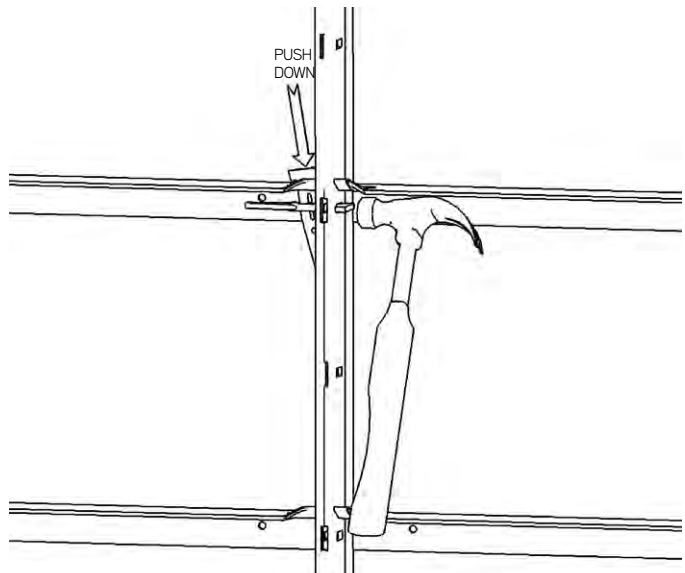

Hammer Strikes Horizontal Wedge Bolt

Steel Fillers and Long Bolts

1", 1½" and 2" Steel Fillers are cold formed U-shaped steel. These fillers utilize a Long Bolt that passes through the filler to grip both adjoining side rails. Tie slots are located in the center of the face of the "U" for wall ties. The Long Bolts pass through the loop end of the ties.

The Long Bolt is punched with two ¼" holes to accommodate a 16D, or 20D nail, or a broken off panel tie end to shorten the bolt for 1", and 1½" steel fillers. See the Adjustable Long Bolt section.

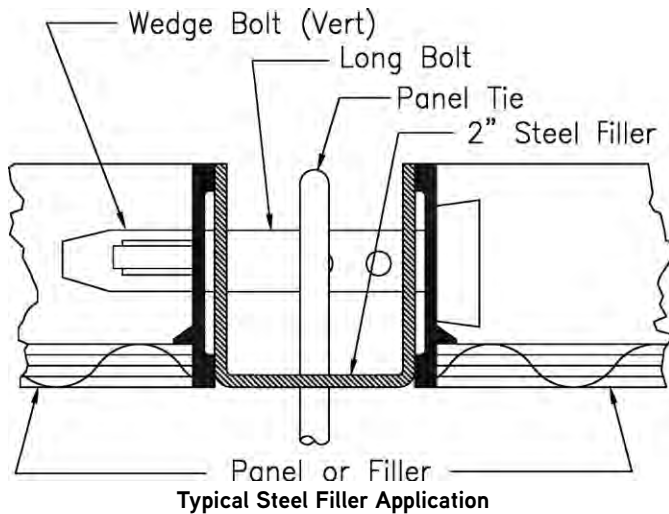

CAUTION: If tension exists in job-built filler, tension rods must be installed through panel siderails. If compression exists, lumber blocking is required.

Adjustable Long Bolts

We recommend that the tapered end of all of the Adjustable Long Bolts at each fill-in joint be pointed in the same left or right direction. The width of the filler determines if the Wedge Bolt is located in the slotted hole at the square end or the slotted hole at the tapered end.

Application:

1. For width of fillers from ½" to 2" in ½" increments insert Wedge Bolt in slotted hole at tapered end.
2. For width of fillers from ¼" to 1¾" in ½" increments insert Wedge Bolts in slotted hole at square end.

NOTES:

- Form Ties must be used at all filler conditions.
- Do not short stop with nail where there will be a high shear load on nail.

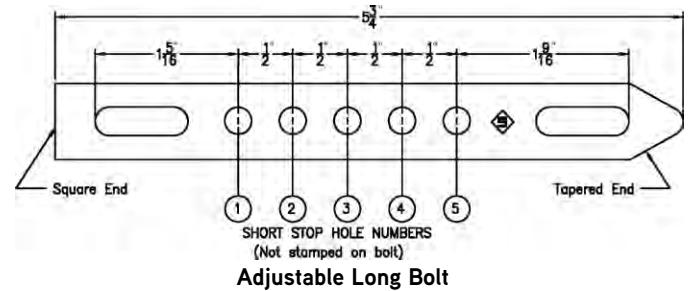

ADJUSTMENT RANGE

Short Stop Hole No.	Width of Filler Wedge Bolt at Square End	Width of Filler Wedge Bolt at Tapered End
1	0"	2" to 2¼"
2	¼" to ½"	1½" to 1¾"
3	¾" to 1"	1" to 1¼"
4	1¼" to 1½"	½" to ¾"
5	1¾" to 2"	0" to ¼"

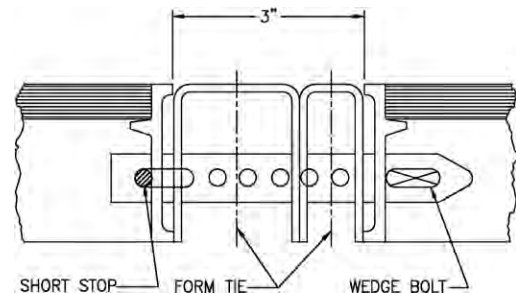
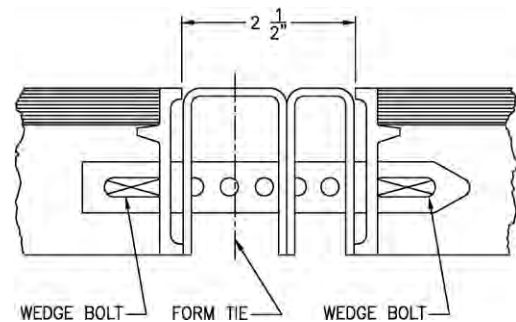
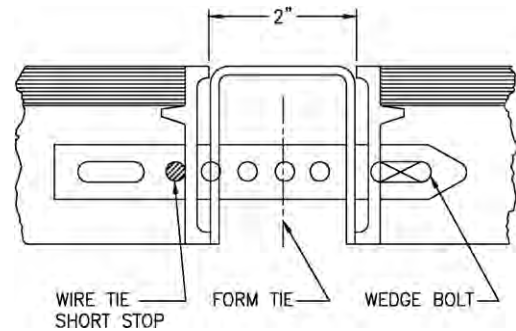

Typical Examples of Adjustable Long Bolt and Steel Filler Applications

**Job Built Fillers
(Utilizing Filler Angles)**

Filler Angles provide a means to construct a custom size filler of 3/4" plywood that can be connected to side rails of adjoining forms. Job-built fillers are recommended where reinforcing steel, pipes, etc., must protrude through the form face.

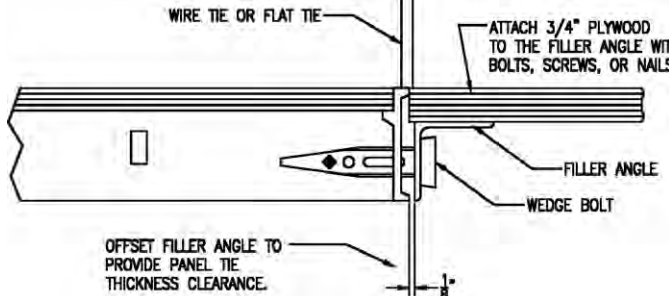

Typical Filler Angle Attachment

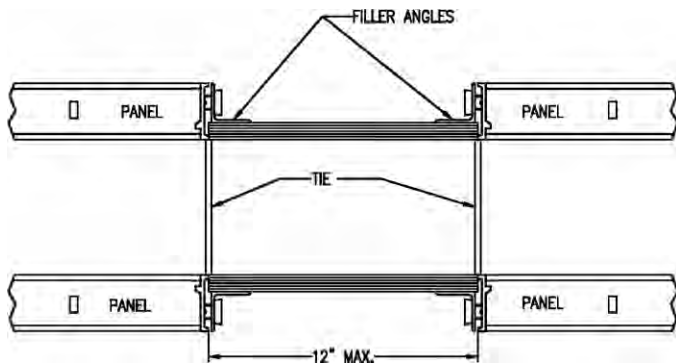

Typical Job-Built Filler with Filler Angles

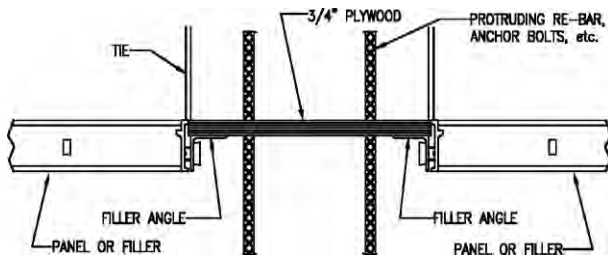

Typical Job-Built Filler with Rebar Penetrations

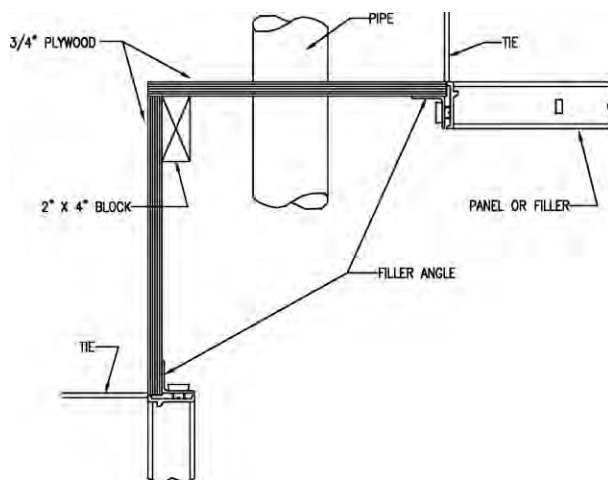

Custom Inside Corner Job-Built With Two Filler Angles

Stripping and Tie Breakbacks

Panel stripping can be started at any point after walers and connecting hardware are removed. Usually, it is easier to start stripping forms at an outside corner, or adjacent to a 1", 1 1/2" or 2" filler. It is recommended that hardware be placed in a metal container so that none of the pieces are lost.

CAUTION: Symons recommends wearing gloves, safety shoes and safety glasses during the erection and stripping processes.

Breakback of ties is recommended within two days after stripping. With S-Panel ties, a 1/2 to 3/4 twist will break them back.

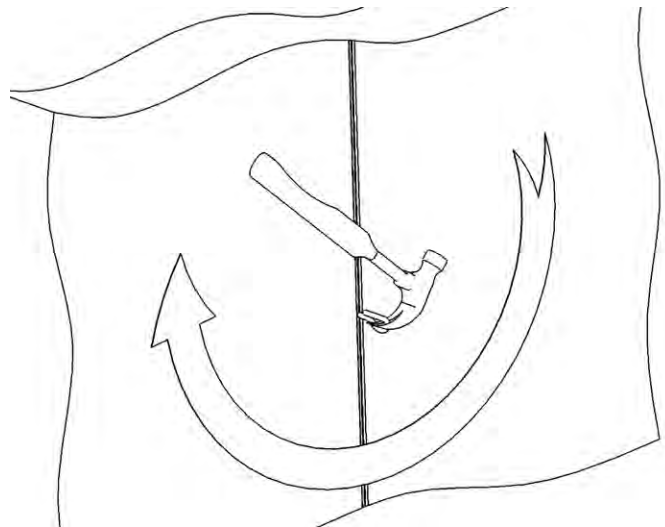

Breaking Back a Wire Tie

Flat ties are broken off by a firm hammer blow hitting the edge of the tie as shown. A blow against the flat side of the tie will bend the tie.

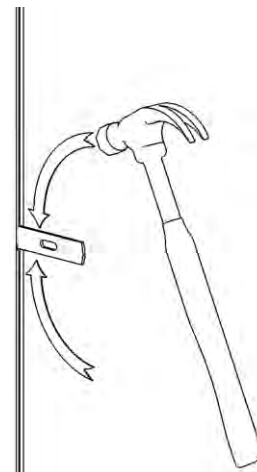

Breaking Back a Flat Tie

CAUTION: Care should be used in striking ties with a hammer during the stripping process.

TIES

Tie Capacities

Safe Load Ratings
 Symons S-Panel and Flat Ties

	Ultimate Load (lb)	Rating According to Factor of Safety 2.0 (lb)
Standard Duty Panel Tie	4,500	2,250
Standard Duty Threaded Tie ⁽¹⁾	4,200	2,100
Standard Duty S-Base Tie	3,000	1,500
Heavy Duty Panel Tie	6,000	3,000
Standard Duty Flat Tie	6,000	3,000
Heavy Duty Flat Tie	7,000	3,500
Heavy Duty Adjustable Flat Tie	7,000	3,500
Toggle Tie ⁽¹⁾	4,200	2,100

⁽¹⁾ Tie capacity is dependent on adequate anchorage

Tie Alignment

Occasionally, to simplify erection, it may be advantageous to connect ties between opposing form joints that are not exactly opposite. Either panel ties or flat ties can be safely swung laterally up to 1" on 8" walls, or up to 2" on 16" walls. Exceeding the 1:8 angle proportion will diminish the tie strength or cause failure by bending through the tie breakback crimp. Also, the wall thickness dimension will foreshorten appreciably.

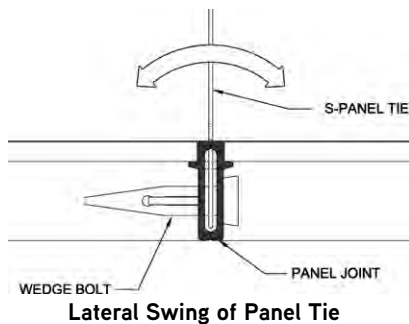

Panel ties can swing up or down up to 1" on 8" walls, or up to 2" on 16" walls. An example would be where a plate is utilized under one form side only. A 3/4" thick 1 x 4 plate under one side for any wall thickness 6" or more, or a 1 1/2" thick 2 x 4 plate under one side for any wall 12" or thicker are within the 1:8 angle proportion.

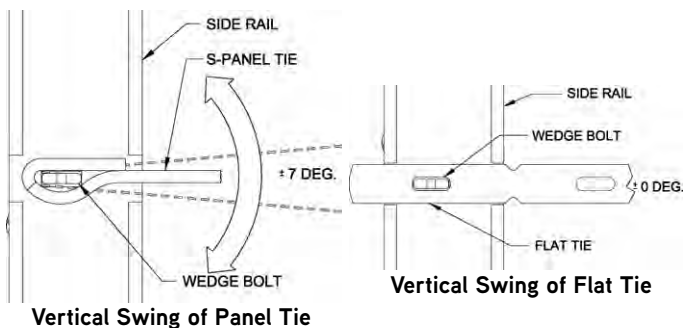

Tie Spacings

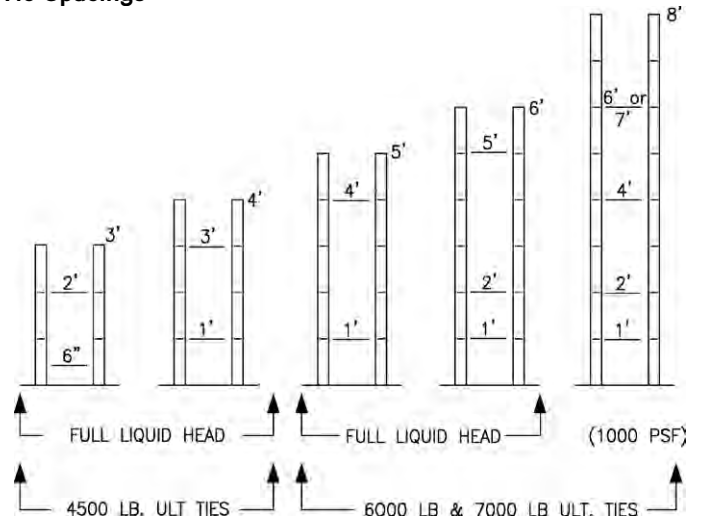

**Tie Spacings
 Walls 8' Tall or Less**

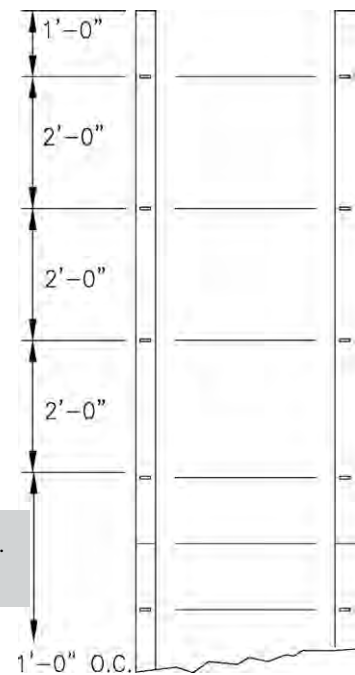

**Tie Spacings
 Walls Taller Than 8'
 6,000 lb Ultimate Tie Capacity**

NOTE: Ties at 1' O.C.
 7' or more from top.

SPECIAL PURPOSE TIES AND HARDWARE

The ultimate load capacity of threaded ties is 4,200 lbs which provides for a safe load of 2,100 lbs at 2:1 safety factor. There are three types of threaded ties.

Single End Threaded Ties

A typical application provides the varying fractional inch wall tie requirement common to most battered walls.

Threaded ties have a special 1/4" x 20 thread and require use of a special 1/4" x 20 threaded nut. Spreader action is provided through utilization of the Keeper Bolt. The Keeper Bolt takes the place of a standard Wedge Bolt at each threaded tie panel connection. The tie contains a breakback flat at the threaded end, and a breakback tool must be used to twist the tie end. The ease or effectiveness in performing the tie breakback will depend upon how deep the breakback flat is embedded in the concrete. Breakback depths up to 1" should readily twist off.

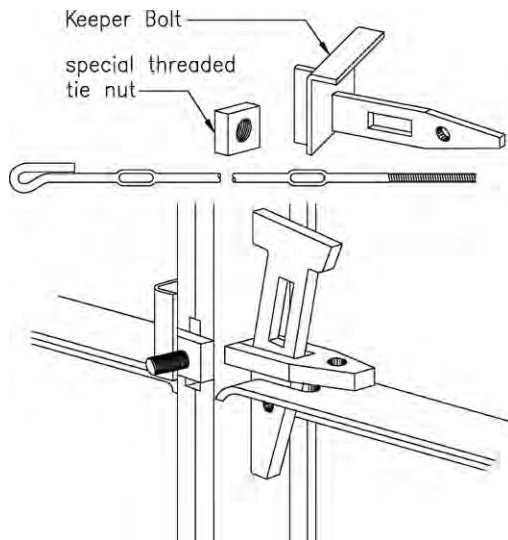

Threaded Tie Connection to Steel-Ply

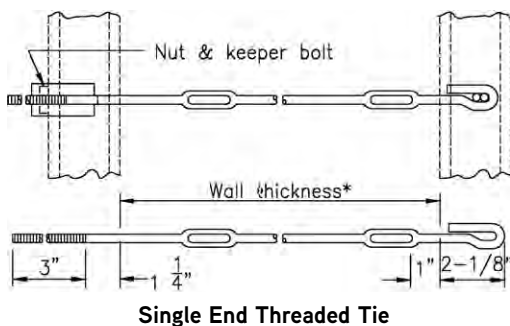

Single End Threaded Tie

Adjustable Single End Threaded Ties

This tie has approximately 5" of length adjustment available but does not have a breakback flat at the threaded end. It should only be used in applications where a minimum below surface breakback is not required; such as, the back fill side of a battered retaining wall.

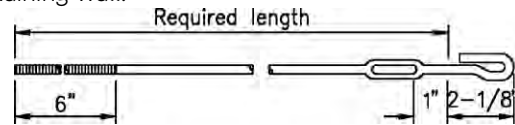

Adjustable Single End Threaded Tie

Ties Threaded Both Ends

Thread at both ends offers twice the range to adjust to job variations in wall thickness and still retain reasonable assurance toward breaking back the tie utilizing the jaw grip breakback tool.

Single End Threaded Toggle Ties

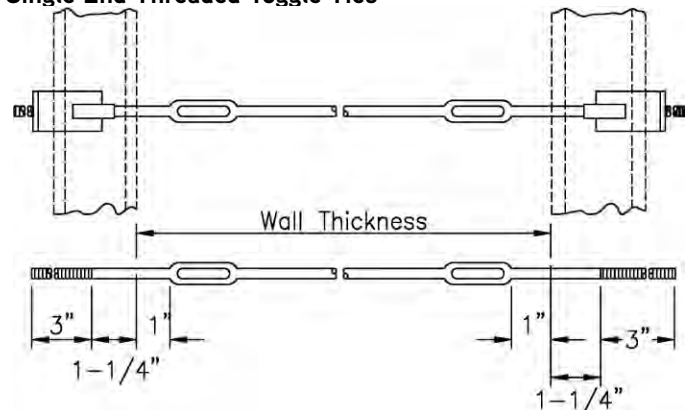

Tie Threaded Both Ends

THREADED TIE NOTES:

- Safe recommended load on the special 1/4" x 20 tie thread is 2,100 lbs. @ 2:1 safety factor.
- Standard thread length provides 2" of adjustment.
- The capacity of the toggle ties is dependent on adequacy of anchorage of toggle.
- Recommended vertical spacing for any type threaded tie 1'-0" O.C. for all wall heights.
- Extreme care should be taken to assure each nut is adjusted so that each tie will carry its share of form load. Use the Keeper Bolt.

The toggle end threaded tie facilitates two basic application connections:

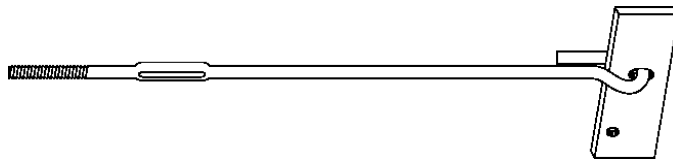

Single End Threaded Toggle Tie

1. Toggle ties provide for field weld attachment to steel piling, structural steel, etc.

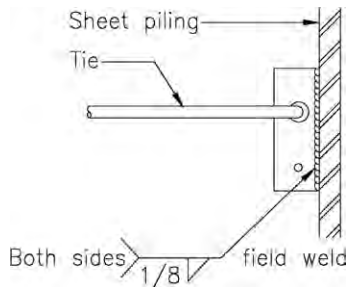

Single End Threaded Toggle Application #1

2. Toggle ties provide anchorage to lumber or steel sheathing by inserting the toggle through a 7/8" diameter hole in the sheathing and securing its bearing position with an activating wire.

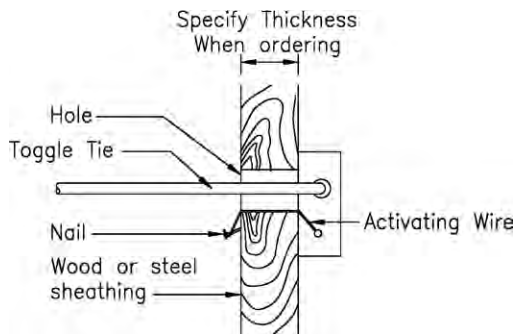

Single End Threaded Toggle Application #2

#1 Cone Ties

#1 Cone Ties and Z-Tie Holders are used for job-built forms comprised of 3/4" plywood, 2x4 studs and double walers. Ties must be placed before second adjoining form is erected. In most cases, outside walls are erected first, ties are secured, and then the inside wall is erected, guiding on the protruding ties.

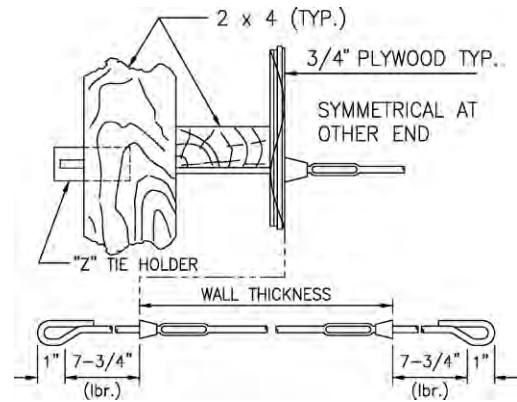

#1 Cone Tie

#2 Cone Ties

#2 Cone Ties and Z-Tie Holders facilitate tying vertical panels opposite job-built forms comprised of 3/4" plywood, 2x4 studs and double 2x4 walers. Normally, it is advantageous to erect the job-built side first with ties and bracing installed. The Steel-Ply panels on the opposite side would be automatically aligned parallel to the previously waled job-built forms.

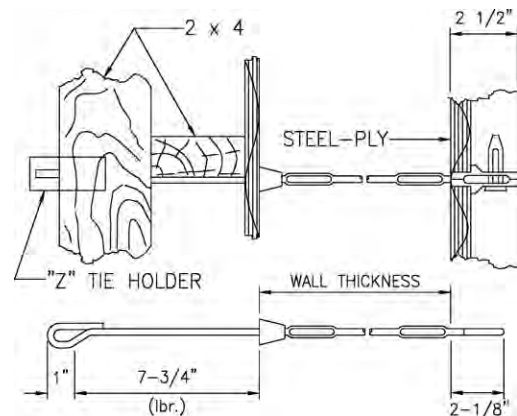

#2 Cone Tie

#2A Cone Ties

#2A Cone Ties and Z-Tie Holders will connect vertical panels opposite job-built forms comprised of 3/4" plywood and double 2x4 walers directly against the plywood (no studs). Tie loops are perpendicular to each other.

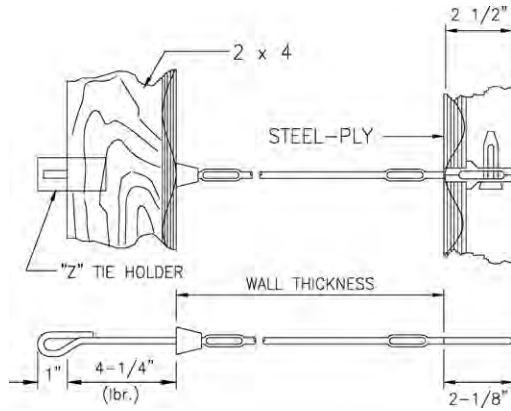

#2A Cone Tie

S-Pilaster Ties

The overall length of a pilaster tie positions opposite wall panels at a given wall thickness. The breakback flat at one end is moved inboard to establish a breakback point on the tie ahead of a brick ledge or other type boxout.

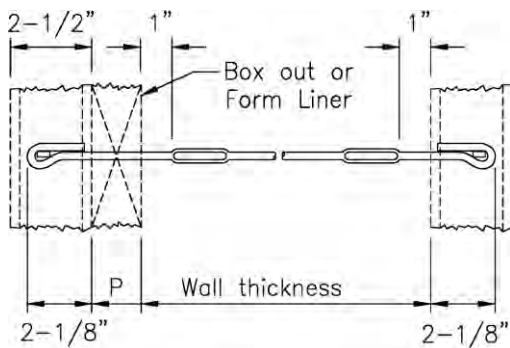

S-Pilaster Tie

Double pilaster ties have special breakbacks positioned from both ends of the tie.

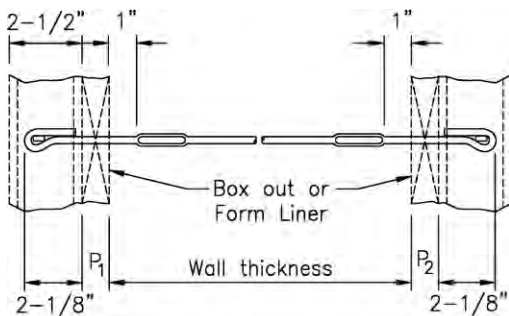

S-Double Pilaster Tie

Base Tie Bolts

The Base Tie Bolt will secure either a panel tie or a flat tie to an end rail or a side rail resting on a footing or where panels butt against an existing vertical surface. One end of the tie must be connected to the first form side prior to its placement. The tie is then in position to receive the opposite form side. The Base Tie Bolt first pass through the ties and then through the panel connecting slots. The connection is secured by a 16d nail inserted through a nail hole in the nose of the Base Tie Bolt.

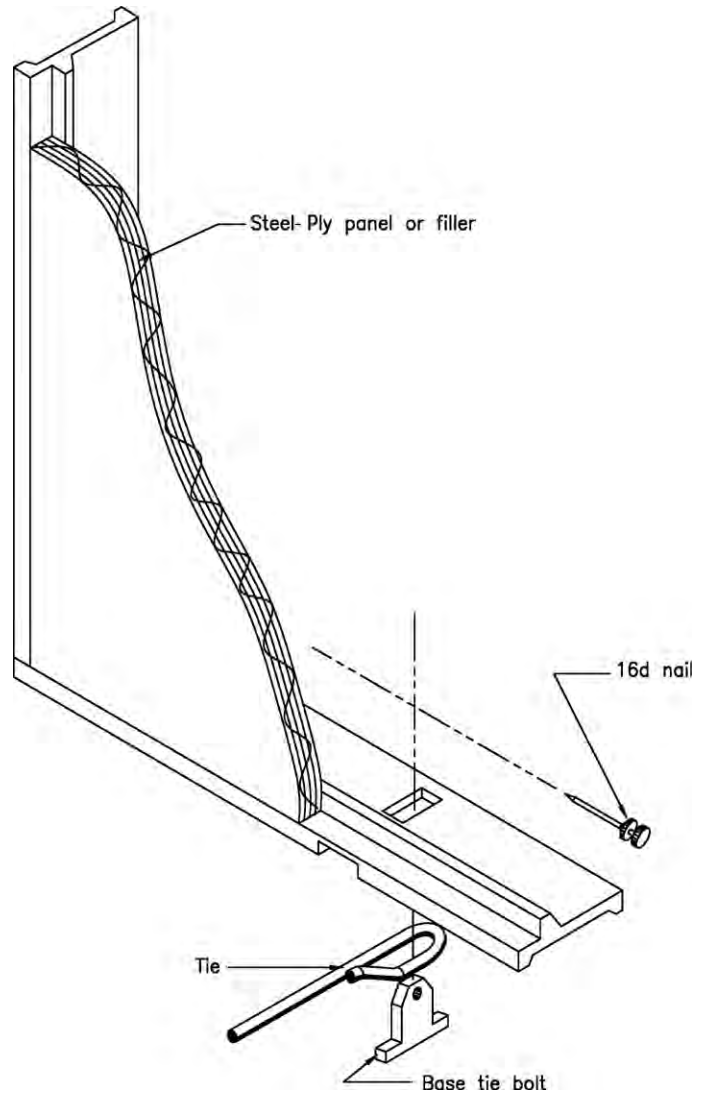

Base Tie Bolt Application

S-Base Ties

The S-Base Tie has an up-turned open loop at each end which protrudes up through the bottom rail connecting bolts slots. Wedge Bolts insert through the protruding loop ends.

Pre-Bent Ties

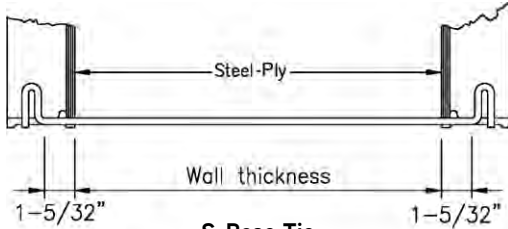

**S-Base Tie
(No Breakback Standard)**

(Many types available)

Unusual wall shapes on occasion warrant the need for special factory pre-bent ties. The form joint points of connection for pre-bent ties are predetermined and located on the engineering layout furnished.

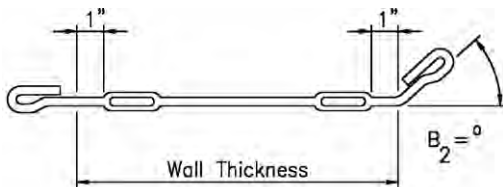

Pre-Bent Tie

CAUTION: Do not attempt to bend ties on the job. Bent tie capacity is less than straight ties. The greater the bend, the less the capacity. Consult a qualified Symons representative for capacities.

ACCESSORIES

Pipe Walers

The Pipe Aligner Hook will secure 1 1/2" (schedule 40) pipe or 1.90" O.D. tubing for use as walers. The aligner hooks position in the dado slots between side rails at either 6" or 18" from the top and/or bottom end rails and two Wedge Bolts make the connection.

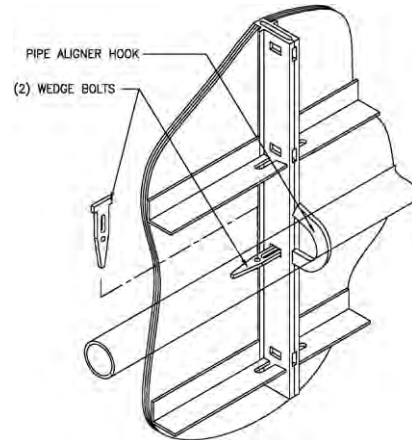

Pipe Aligner Hook Installation

Attachment procedure requires that the pipe waler length be held in position prior to inserting the aligner hooks into the form joint dado slots. The first (lateral) Wedge Bolt is tapped through the connection with a hammer. A snug tightening action results due to the slight under tolerance length of the aligner hook. A second locking Wedge Bolt secures the connection.

Pipe walers should not be utilized as load gathering walers as the Pipe Aligner Hook is not designed to support concrete pressure loads and the pipe may crush or bend. Two pipes can be lapped and clamped at the same Wedge Bolt connection by utilizing two Pipe Aligner Hooks. The first Pipe Aligner Hook is attached with two Wedge Bolts (normal fashion). The second Pipe Aligner Hook holds the other pipe and is attached to the protruding end of the lateral connecting Wedge Bolt. A double head nail may be inserted in the Wedge Bolt's nail hole as a keeper.

Alignment continuity can be accomplished by lapping pipes over two or more panel joints and utilizing two or more double hook positions.

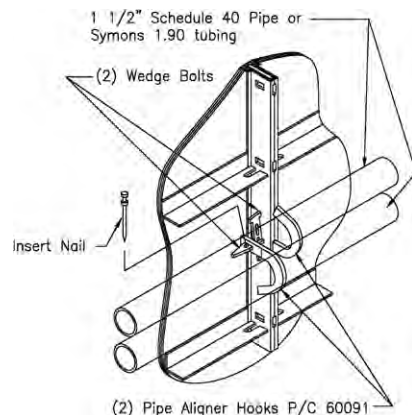

Installation of Two Pipe Aligner Hooks

3" Aligner Channels / 3" Channel Aligner Brackets

Single 3" Aligner Channels provide excellent straight wall alignment when they are attached with 3" Channel Aligner Brackets and 8" Gang Waler Rods. Curved walls can be aligned with 3" Aligner Channels that have been custom rolled to the required curvature.

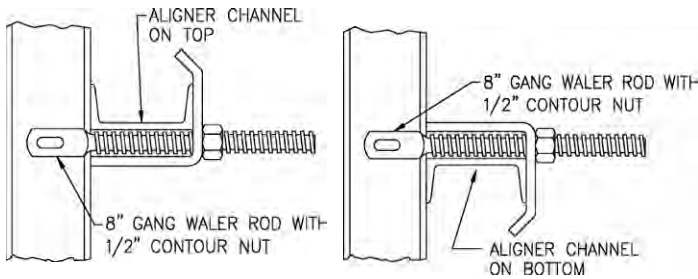
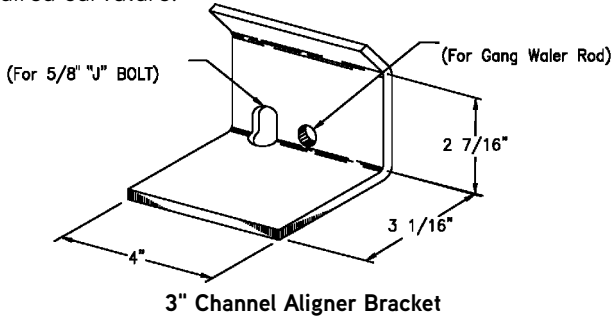

**Typical Application
Aligner Channel on Top or Bottom**

Channels can be lapped and clamped at the same Wedge Bolt connection by utilizing a Gang Waler Plate. In order to lap past each other, the 3" Aligner Brackets must be installed with one 3" channel above the Gang Waler Rods and the other channel below the waler rods.

Lapping channels and clamping with Gang Waler Plates at two or more panel joints, provides alignment continuity of one length to the other. Lapping channels also saves cutting longer lengths to fit a shorter dimension.

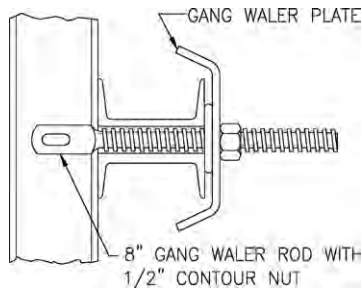

Lapping Channels

Pilaster Forms and Short Bolts

The Pilaster Form is adjustable in 1" increments for pilasters from 1" to 12" deep. There are two connecting flanges, one for even-inch increments, such as 2", 4", 6" and the other for the odd increments such as 1", 3", 5", etc.

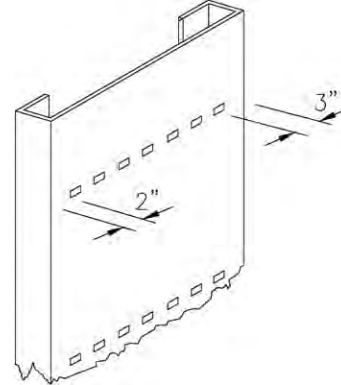

Slot Spacing on Pilaster Form

To determine which end of the flange is even, and which end odd, simply measure the space between the first increment slot and the edge of the form. On one end, the measurement is 2" from the edge, and on the other end, it is 3" from the edge.

If, for example, odd increments are desired, the 2" side of the flange is placed nearest the wall. For even increments, flip the Pilaster Form over, placing the 3" end nearest the wall.

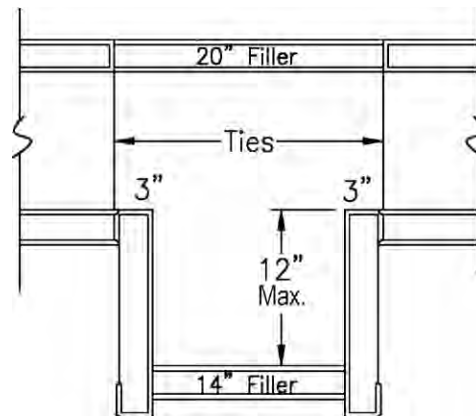

Typical Pilaster Form Application

A Short Bolt eliminates the need for short-stopping or shimming Wedge Bolts, and makes stripping easier when properly installed.

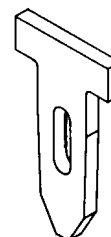

Short Bolt

Where the Pilaster Form joins the panel at the wall and Short Bolts are not available, short-stopping is necessary. Insert a nail in the horizontally placed Wedge Bolt's nail hole, thus drawing up the wedge so that insertion of the vertically placed Wedge Bolt forms a snug connection.

On the opposite, or outside end, where the pilaster is attached to the filler, loose fitting Wedge Bolts can be tightened by "shortstopping" or shimming. To shim, slip an extra Wedge Bolt horizontally on the connecting Wedge Bolt, insert through pilaster and filler, and lock in place with a third Wedge Bolt (see illustration).

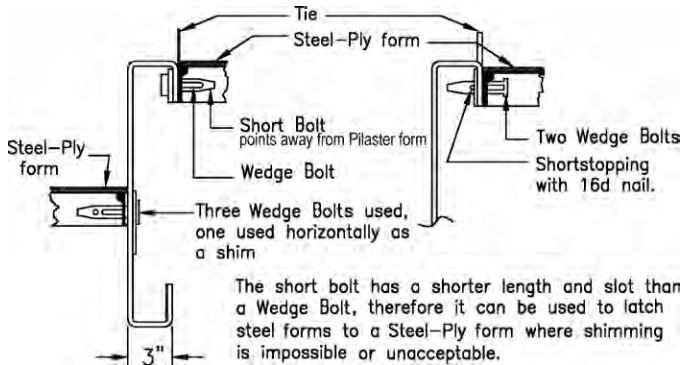

Each Pilaster Form displaces 3" of wall face dimension adjacent to the wall tie at its flange-to-panel connection, therefore the form opposite the pilaster must be 6" wider than the pilaster being formed.

Pilaster Braces

The Pilaster Brace eliminates the need to use lumber for bracing the corners of Pilaster Forms in order to achieve right angle corners on pilasters.

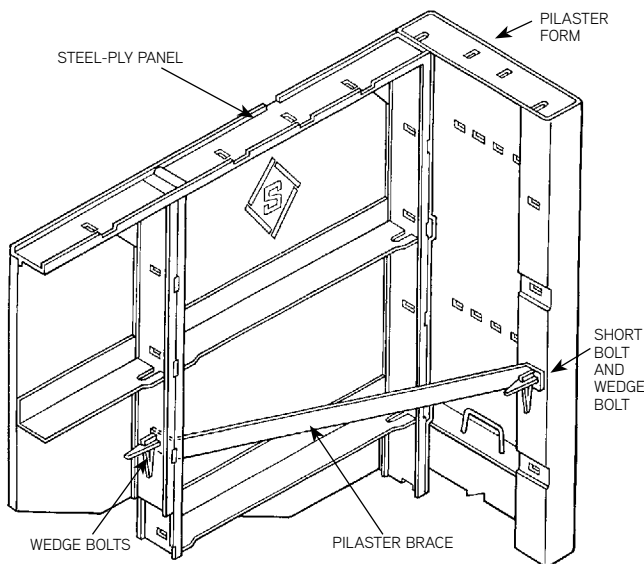

Typical Pilaster Brace Installation

The Pilaster Brace is needed on only one side of the pilaster.

Two braces are required on the bottom form and one brace on each additional stacked form. The first brace should be located 6" or 18" from the bottom of the pour. Additional braces should be located 6" or 18" below the end rail of each form.

Avoid interference with walers or ties.

A panel must be located next to the pilaster form to facilitate brace connection.

Attach Pilaster Braces with Steel-Ply Wedge Bolts at the panels and a Short Bolt at the Pilaster Form

Pilasters formed with Inside Corners

Pilasters are also formed using Inside and Outside Corners with appropriately sized fillers.

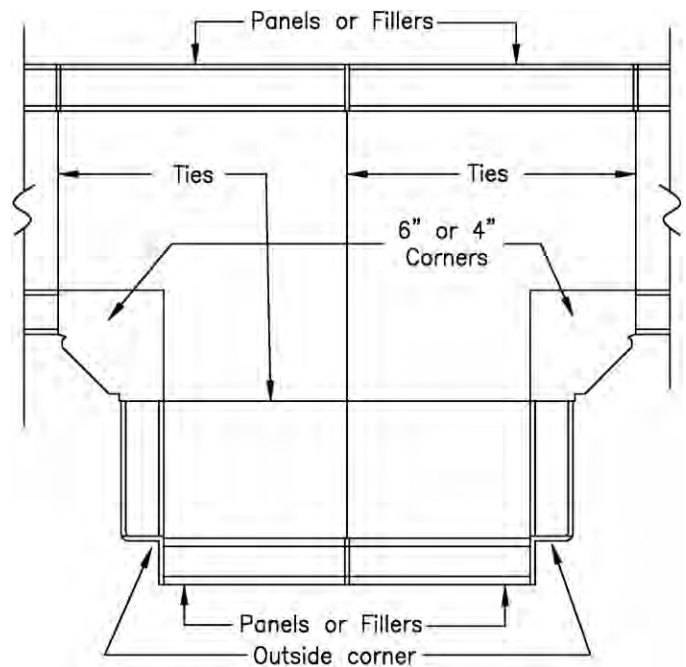

Typical Panel, Filler and Panel Tie Configuration for Pilasters

NOTE: Flat Ties cannot be crossed as shown in diagram above.

Bay Corners

Inside Bay Corners opposite Outside Bay Corners form a 135° angle wall corner. The Inside Bay Corner has a 3"x3" face dimension, and the Outside Bay Corner has a 7"x7" face dimension. Panel ties connect at adjoining panel joints the same way as they do on standard 90° corners. Bay Corners can be used horizontally to form wall haunches and sewage treatment plant "Y" Walls.

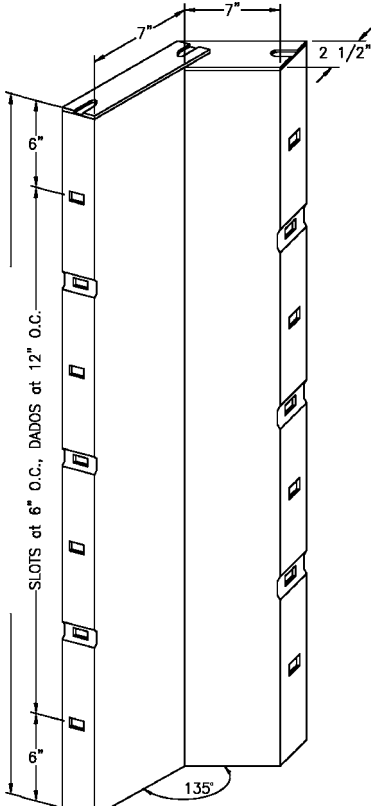

Outside Bay Corner

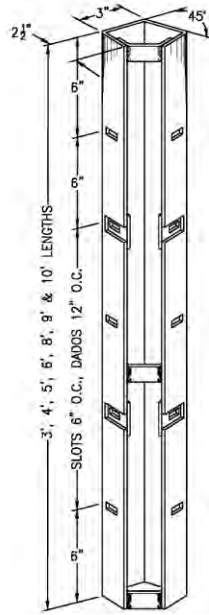

Inside Bay Corner

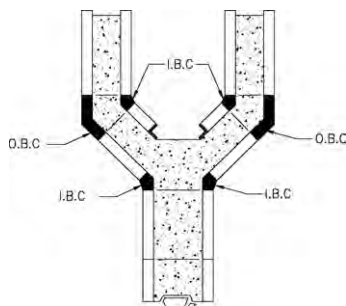

Typical "Y" Wall

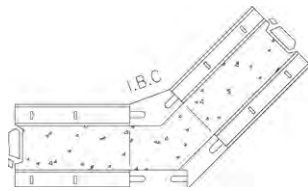

Typical Bay Corner Application

Steel fillers or job-built fillers enable Bay Corners to adjust to any wall thickness.

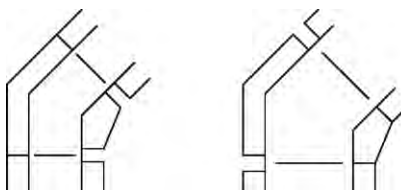

Bay Corners and Fillers

WALL THICK-NESS	FILLER SIZE REQUIRED
6"	1 1/2"
8"	5/8"
10"	1/8"
12"	1"

Bay Corner Brackets

Bay Corner Brackets and two appropriately sized fillers can be used in place of Outside Bay Corners. The brackets should be placed at crossmember locations, starting 1'-0" from the bottom. Do not attach bracket to Steel Fillers.

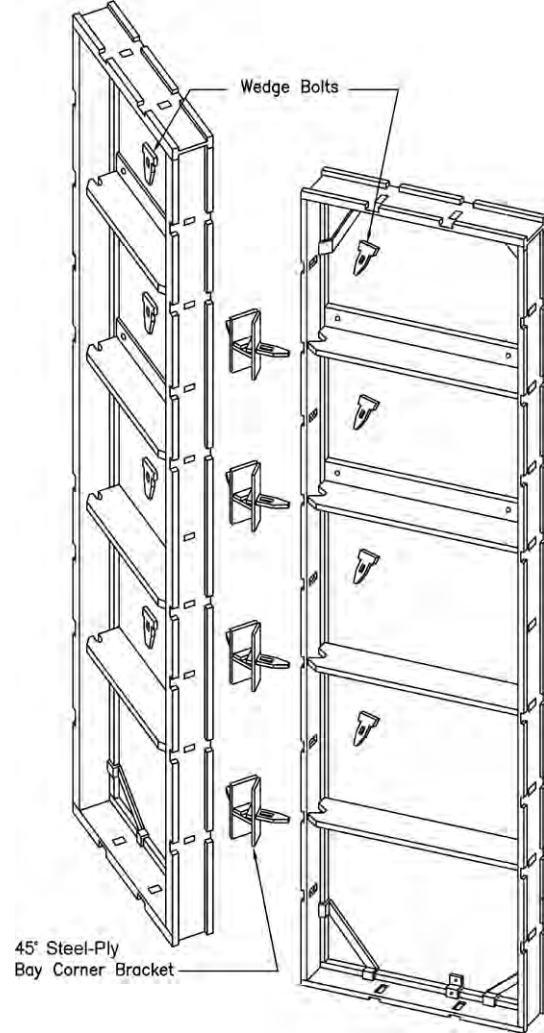

Typical Bay Corner Bracket Installation

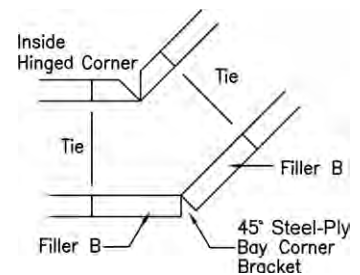
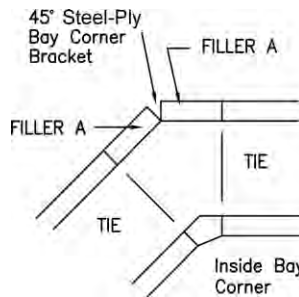

WALL THICK-NESS	FILLER A SIZE REQUIRED
6"	5 1/2"
8"	6 5/16"
10"	7 1/8"
12"	8"

WALL THICK-NESS	FILLER B SIZE REQUIRED
6"	8 1/2"
8"	9 5/16"
10"	10 1/8"
12"	11"

Hinged Corners

The Inside Hinged Corner may be used to form inside corners down to 45°.

The Outside Hinged Corner will form outside corners from 135° down to as sharp as a 5° angle. Always insert connecting Wedge Bolts toward the adjoining panels so that the maximum swing angle will not be restricted

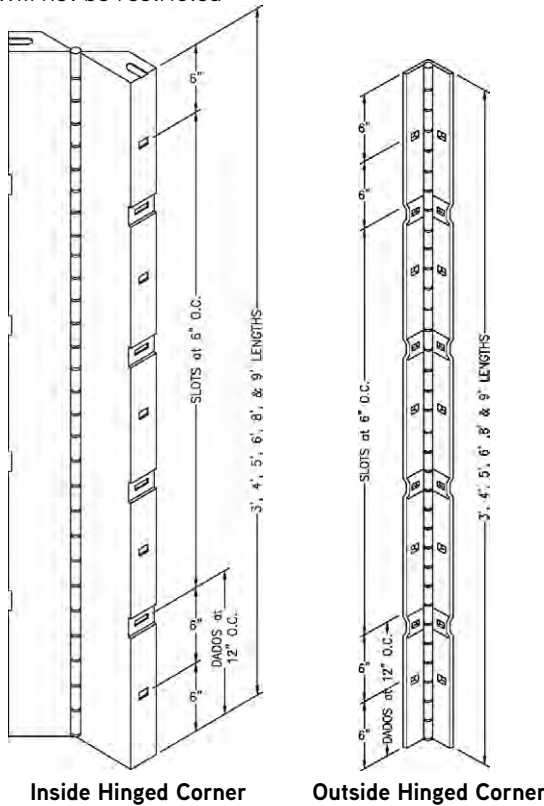

Inside Hinged Corner

Outside Hinged Corner

In most wall applications, Inside Hinged Corners are used opposite Outside Hinged Corners.

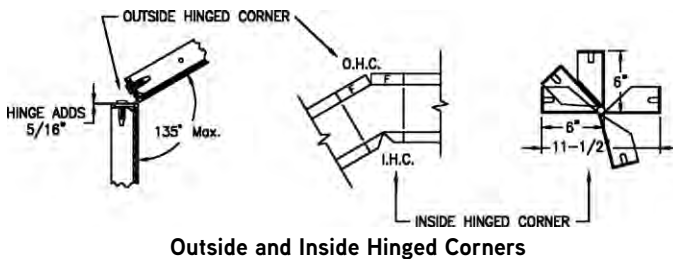

Outside and Inside Hinged Corners

CAUTION: Due to the inherent flexibility of hinges, corners formed should be waled, braced and blocked as required.

CAUTION: Do not use Hinged Corners in column applications. Use Column Hinges shown in Quick Column Hardware section.

Culvert Forms

The Culvert Form creates the chamfered corners that prevail in box culverts. On most chamfer cornered culverts, the roof slab and walls are poured monolithically. Panel ties are usually required at the horizontal form joint between the Culvert Form and the top rail of the inside forms. This means the outside form must also have a horizontal joint at the same elevation, so that tie daddos occur at the same staggered positions at opposing form sides. A top tie is then required over the deck to the outside form on the other wall side of the culvert. The deck forms must be properly shored to support the dead and live concrete placement loads.

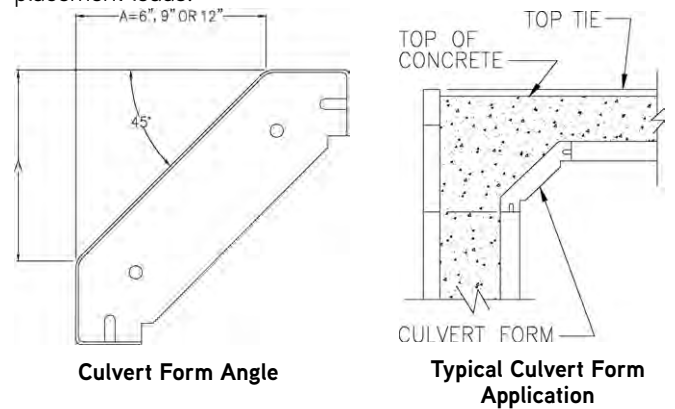

Culvert Form Angle

Typical Culvert Form Application

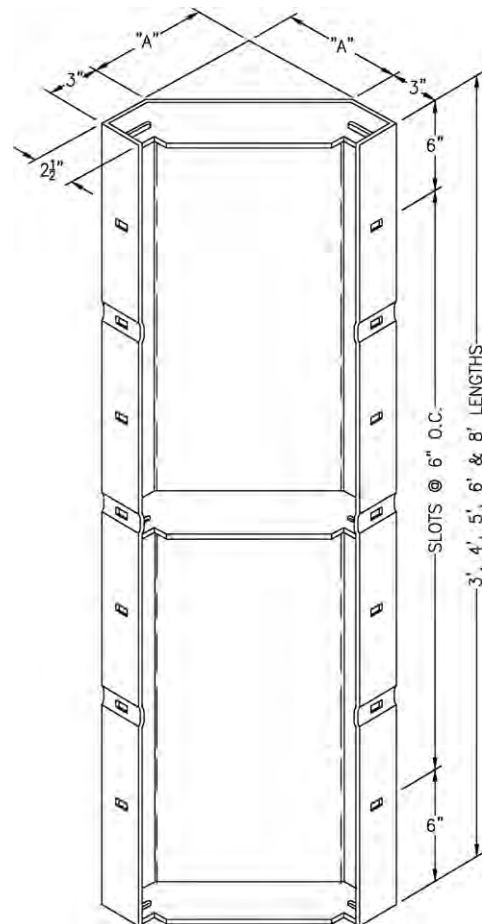

Culvert Form Dimensions

Form Aligners

Form Aligners are required to position forms straight and plumb and are not intended to resist concrete pressure or any other loads.

Symons attachment plates secured to lumber provide a very quick and sturdy alignment connection directly to any panel joint.

The ground end of the aligner can be nailed to either a Symons steel stake or a lumber stake.

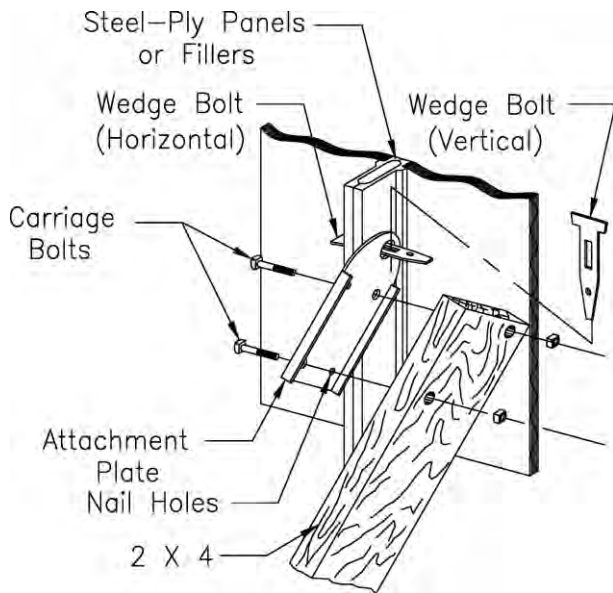

Typical Form Aligner Attachment to Steel-Ply

CAUTION: Wall and column forms must be adequately braced to safely support all foreseeable lateral loads associated with wind, eccentric loading, etc. The materials, quantities, locations and methods of attachment and anchorage of the bracing design shall be the responsibility of the contractor based on job site conditions and applicable industry standards.

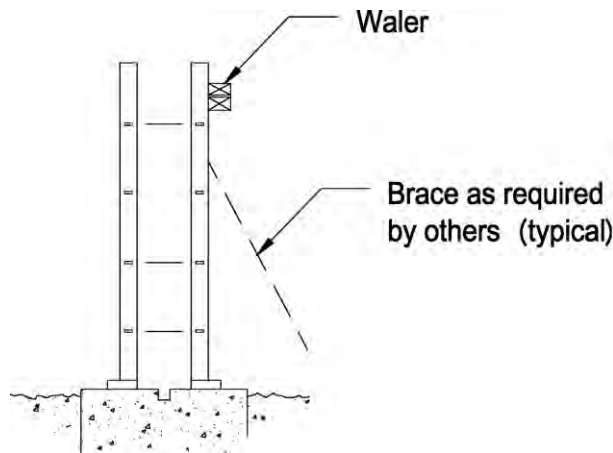

Forms Alignment with Walers and Braces

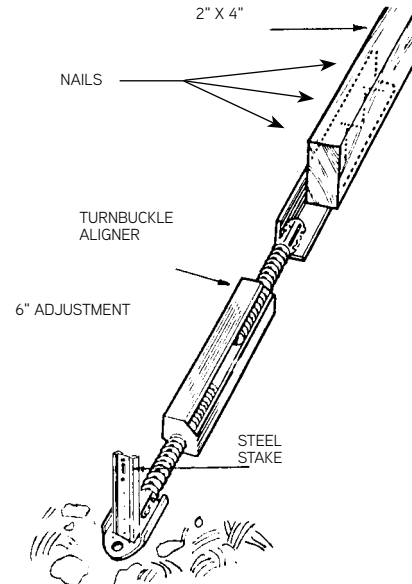

Typical Turnbuckle Aligner Application

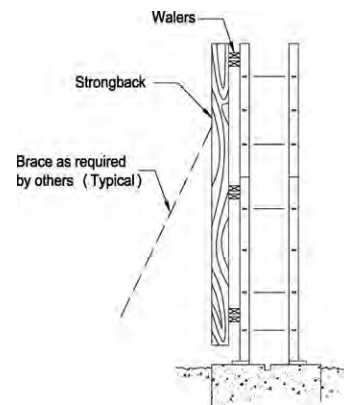

Form Alignment for Stacked Forms

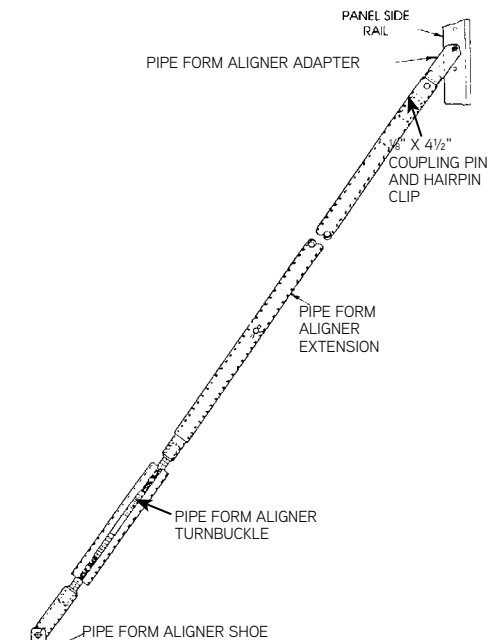

Typical Pipe Form Aligner Application

Turnbuckle Aligners

An additional adjustment advantage may be gained by utilizing a Symons Turnbuckle Aligner nailed to the end of a lumber brace. The lower end of an Turnbuckle Aligner contains a large rectangular slot to accommodate a Symons steel stake. It can also be nailed to a lumber stake.

If the strongbacks are lumber, a wood aligner can be nailed on; or if Symons steel Versiform® walers are utilized as strongbacks, the attachment plate end of the adjustable turnbuckle can be bolted to the strongback with a standard 5/8" x 6" Versiform Fit-Up Bolt.

Pipe Form Aligners

The Symons Pipe Form Aligner is adjustable from 11'-7" up to 20'-9" and connects to side rails by utilizing the Steel-Ply Pipe Form Aligner adapter at the Wedge Bolt slot midway between crossmembers.

A Pipe Form Aligner Adapter is not required to connect directly to vertical Versiform waler strongbacks. Either end of the aligner may be installed between the double 5" waler channel with a 5/8" x 6" Fit-Up Bolt. A Pipe Form Aligner Shoe is utilized at the ground end of the Pipe Form Aligner. It has openings for anchoring with a 3/4" dia. concrete anchor bolt or a Symons flat or 3/4" dia. round steel stake which may be driven into the ground.

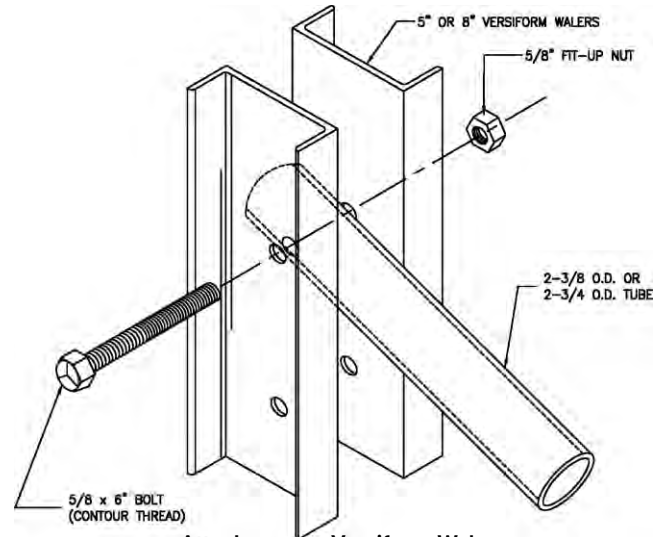

Attachment to Versiform Waler

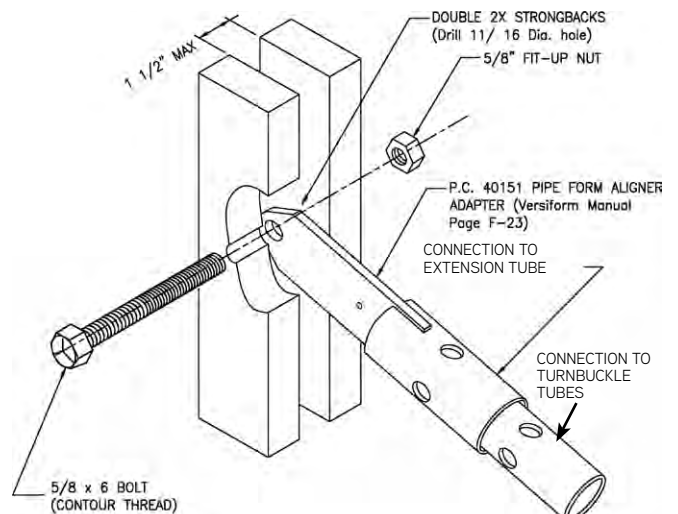

Pipe Form Aligner Attachment to Strongbacks

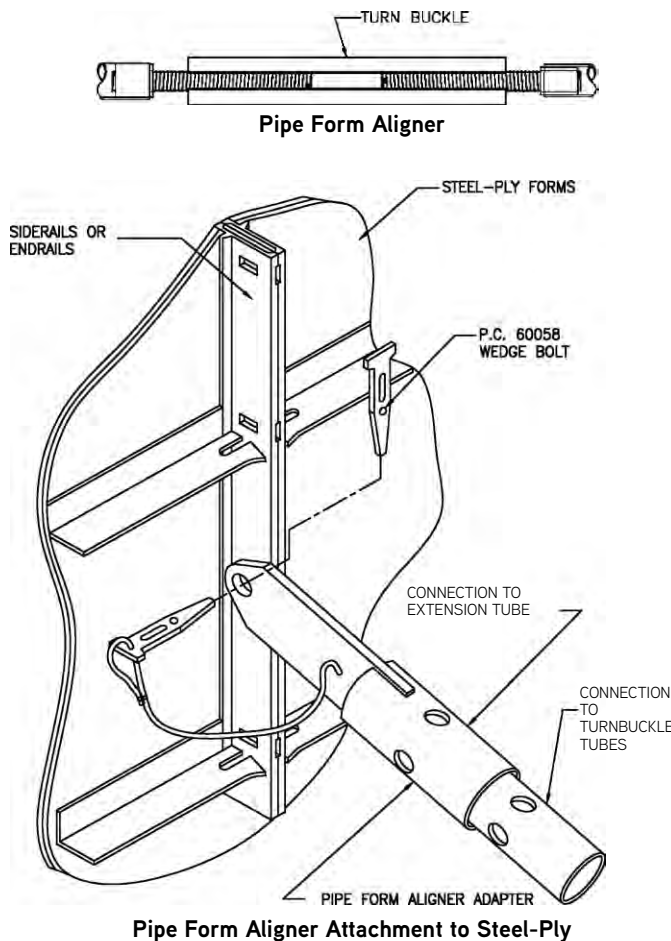

Pipe Form Aligner Attachment to Steel-Ply

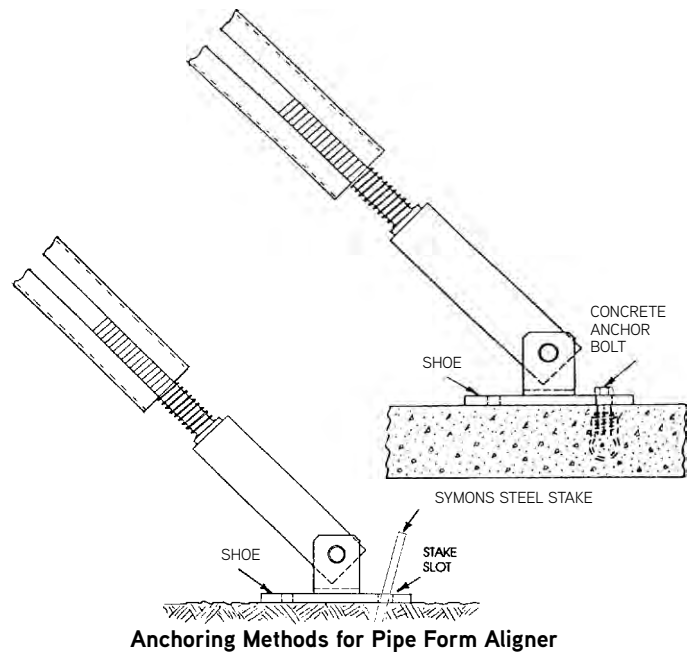

Anchoring Methods for Pipe Form Aligner

Scaffold Brackets

Scaffold Brackets should be installed where one or more levels of work platforms are required for personnel safety whenever access to forming components or concrete placement necessitates work above grade or deck levels.

The allowable load on a Scaffold Bracket is 500 lbs, and brackets shall not be spaced more than 8 feet apart in accordance with applicable OSHA standards, and shall be in compliance with all applicable governmental regulations, codes and ordinances.

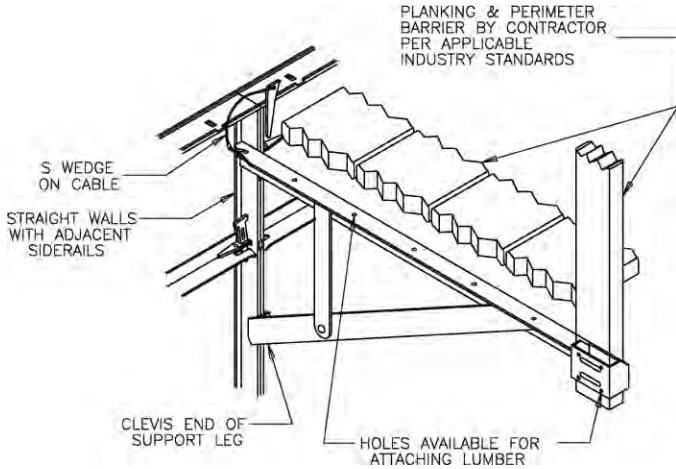

Scaffold Bracket Attachment

Use a Wedge Bolt through the bracket slot and the panel side rails. Lock the Wedge Bolt with the S-Wedge cabled to the bracket. Be sure the clevis on the lower end straddles the side rails.

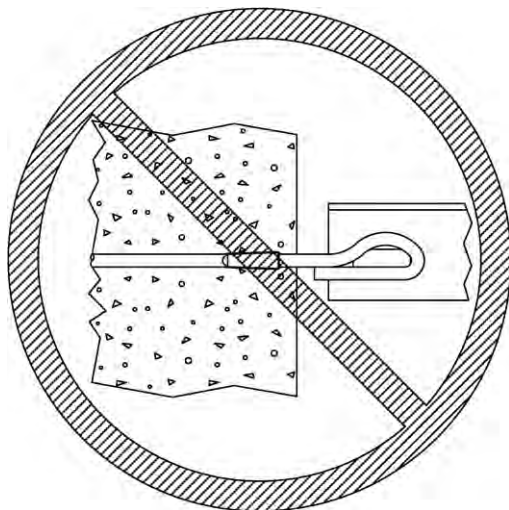

CAUTION: Do not attempt to secure Scaffold Bracket to ties after forms are removed or in any manner other than as illustrated.

Brick Ledge Brackets

The Brick Ledge Bracket is designed for quick attachment of brick ledges and various other types of box-outs such as beam pockets and window openings that extend to the top of a wall. Connection to panels is made with Wedge Bolts.

The nailer plate end of the Brick Ledge Bracket is 3 3/8" long and requires the 2x4 to be the minimum width framing member. In most applications, nailing through the backside of the Steel-Ply panel plywood is required to hold the bottom of the box-out tight against the form face.

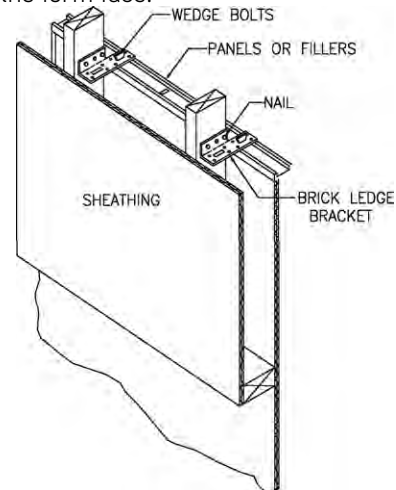

Typical Brick Ledge Bracket Installation

Beam Pockets

The Beam Pocket is nailed to the Steel-Ply form to provide a ledge in the finished concrete for an 8" deep steel beam to set on.

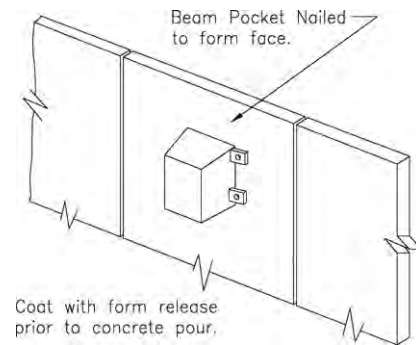

Typical Beam Pocket Installation

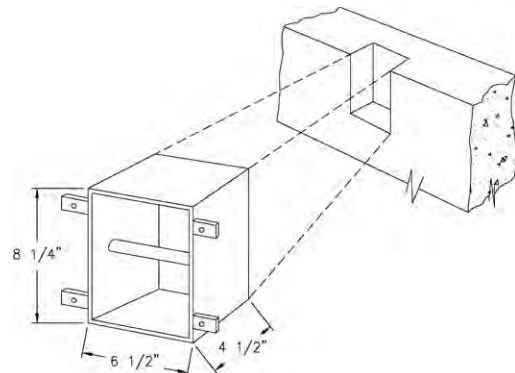

Beam Pocket and Concrete Void

Form Extension Brackets

The Form Extension Brackets are a convenient means for extending a standard panel wall height, an additional 3" to 12" on straight or curved walls. The brackets are designed to be used with 3/4" plywood or sheathing boards and are very practical for saving the most expensive panel plywood at the top of a wall that requires rebar protrusions through the form face. The brackets are 12" in length and have slots at either end for connecting to panels. They also have center slots so that a waler can be attached. The brackets attach with a Wedge Bolt up from the top rail of the panel below and may be locked rigid with an S-Wedge. The S-Wedge is necessary to bridge between the opposite side slots of the bracket while drawing the connecting Wedge Bolt tight.

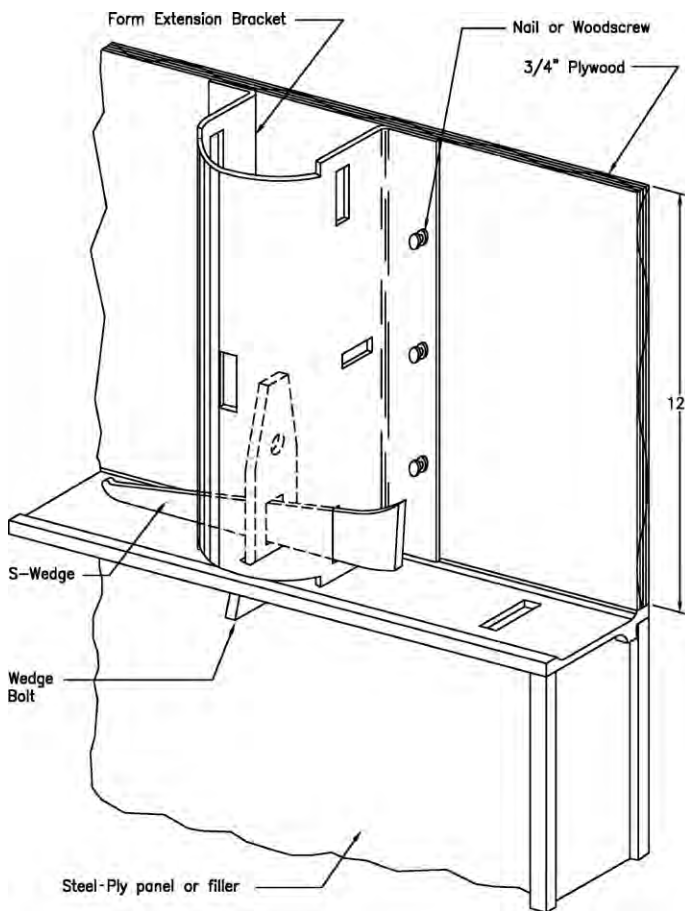

Typical Form Extension Bracket Installation

Cantilever Brackets

Cantilever Brackets suspend an opposing form from the first wall side erected. This makes possible the difference in elevation at the bottom of the forms so that a base slab can be monolithically poured with the wall. The capacity is 700 lbs and maximum spacing is not to exceed panel length when forms are hung horizontally or 8'-0" when hung vertically.

When the suspended forms are horizontal, a Long Bolt with an S-Wedge connects the Cantilever Bracket to the form side rail.

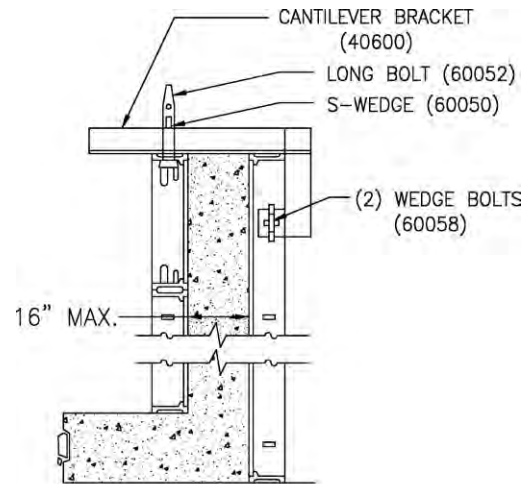

Typical Configuration – Horizontal Suspended Forms

When the suspended forms are vertical, a Cantilever Clip with Fast-Pin couples the Cantilever Bracket to the inside forms at the first connecting bolt slot (6" from the top rail).

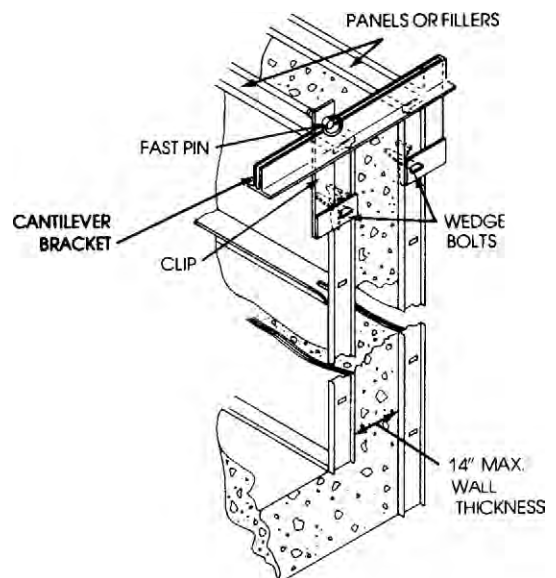

Typical Configuration – Vertical Suspended Forms

CAUTION: Forms must be tied or braced as required.

Haunch Support Brackets

The Haunch Support Bracket is connected to the Steel-Ply side rail using the attachment bolt on the cable and secured with a Wedge Bolt vertically. Then erect posts and stringers. Stringers should be securely attached to the Angle Support Plate as shown below. Formwork, stringers and posts must be in place and braced prior to placing any formwork or planking on Haunch Support Brackets.

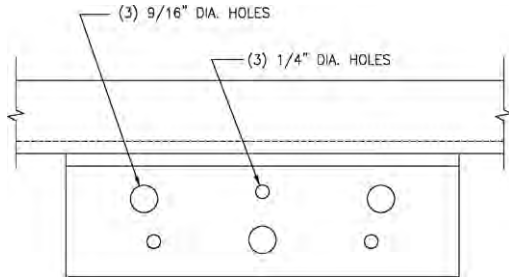

Haunch Support Bracket Hole Configuration

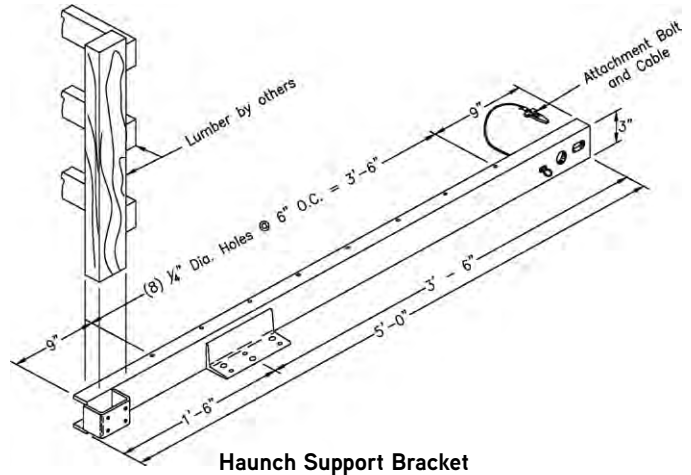

Haunch Support Bracket

Boxout by others

Suggestion: To provide a nailing surface for planking & boxout, nail a 2x4 flat to bracket prior to erection.

Guardrails & posts by others.

Planking by others.

Haunch Support Bracket

W8x10, Aluminum Beam or Joist, or lumber (see page 19 for connections).

Crossbracing & lateral bracing by others.

Post Shore, H.D. Shoring, or post by others with positive connection to stringer.

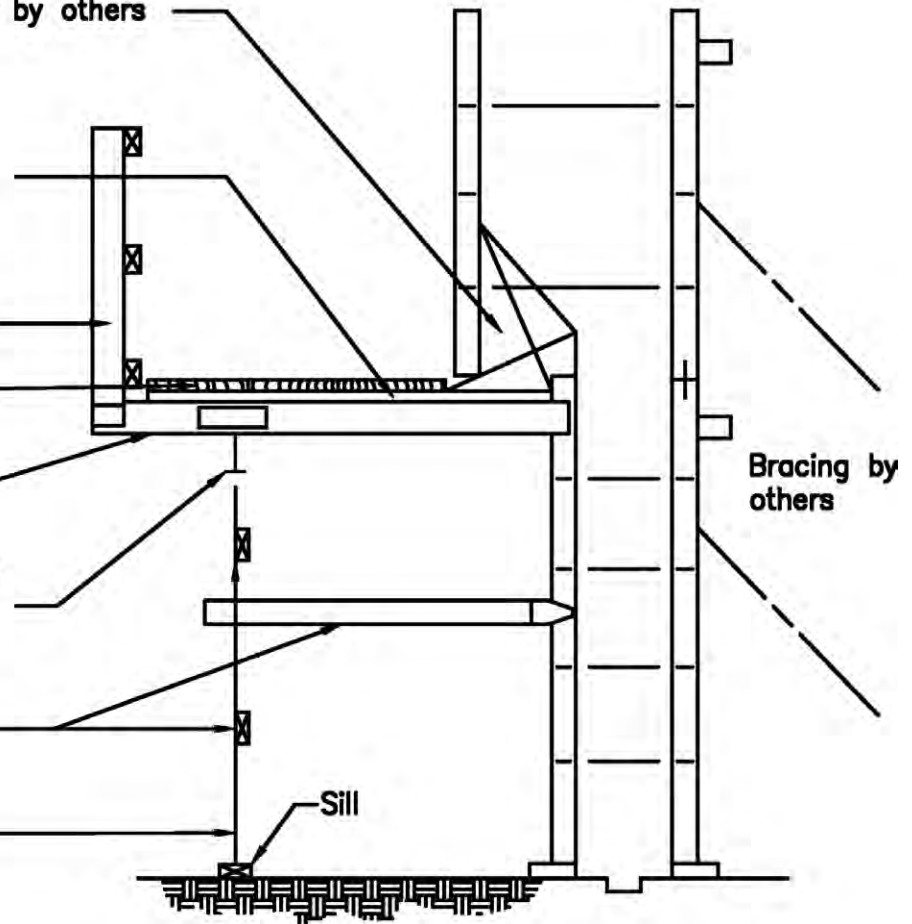

Typical Haunch Support Bracket Application

CAUTION: Grade must be sufficiently compacted to withstand all imposed loads without settlement.

IMPORTANT: Above Caution must appear on layout drawing

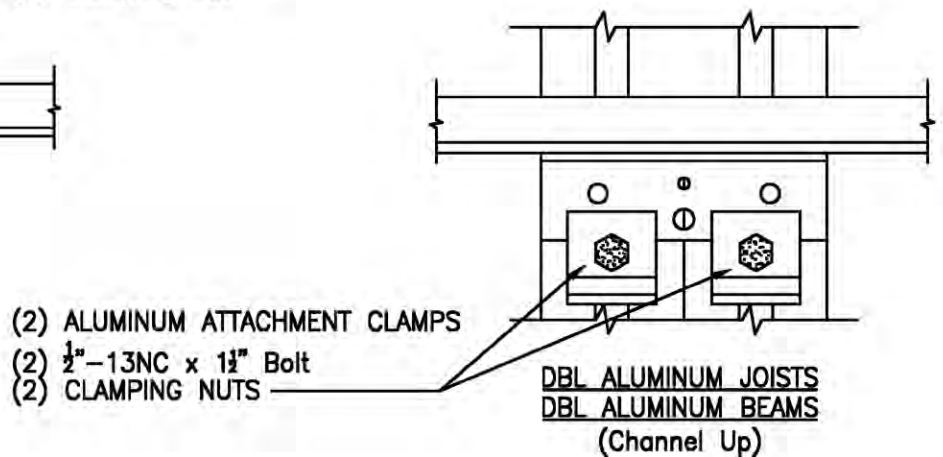
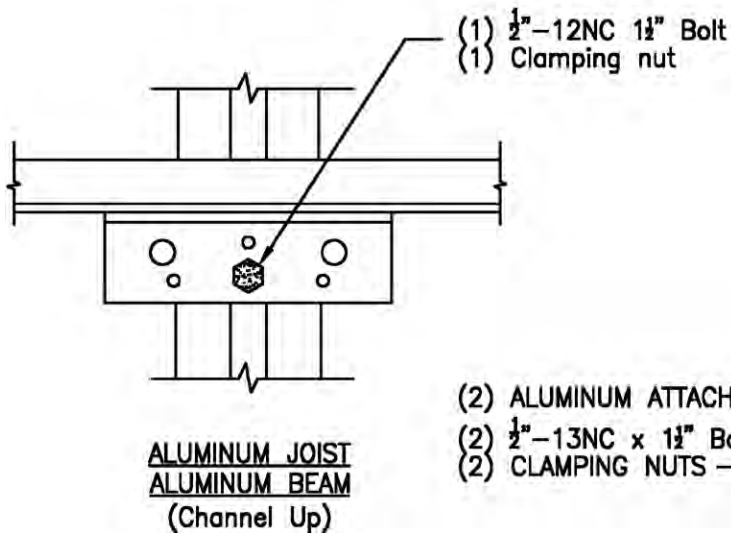
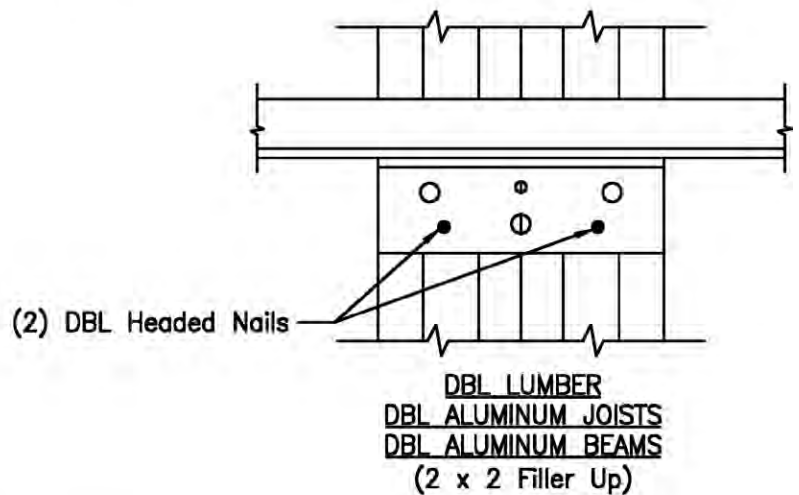
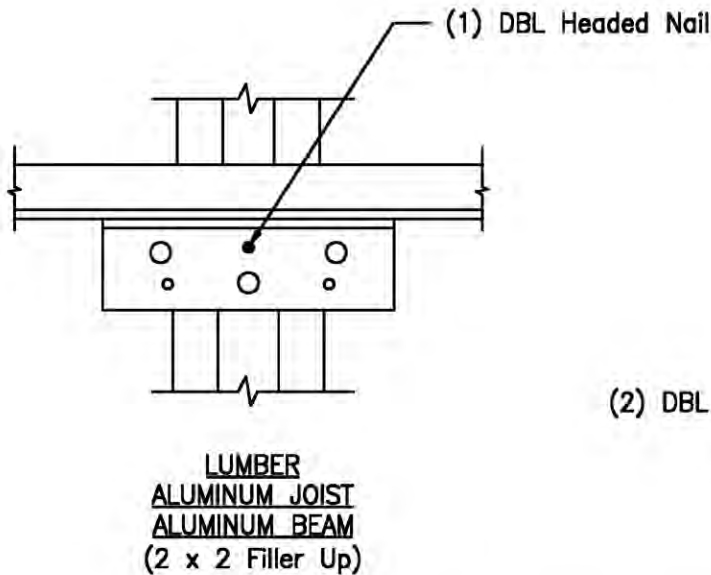
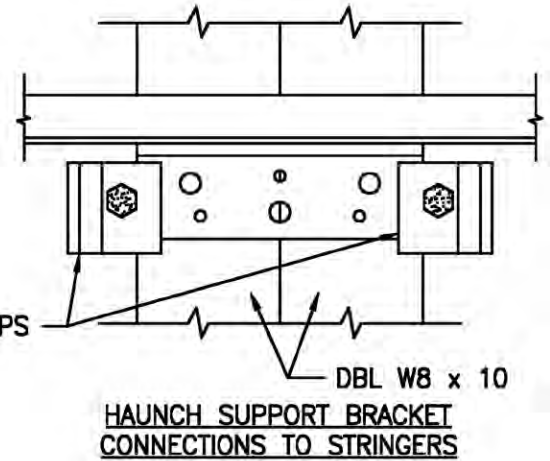
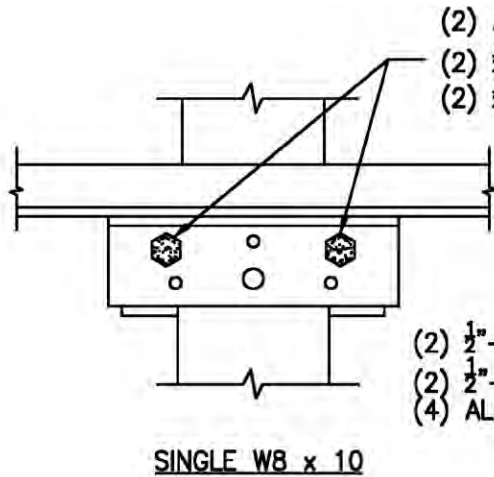

Footing Forming with Steel-Ply Panels

Footing, pad and slab forming with Steel-Ply is made easy with the Footing Corner Bracket and the Stake Plate. Two Footing Corner Brackets at each corner, one on top and one on the bottom, hold the panels firmly and at virtually any dimension that your job requires (2" increments). The Stake Plates are then positioned along the top edge of the Steel-Ply panels as needed for steel stakes to hold the forms in place against the concrete pressure. Either 3/4" round or I-beam steel stakes can be used with the Stake Plate. The Stake Plates can be located midway between Steel-Ply crossmembers and end rails to provide access for a stake puller

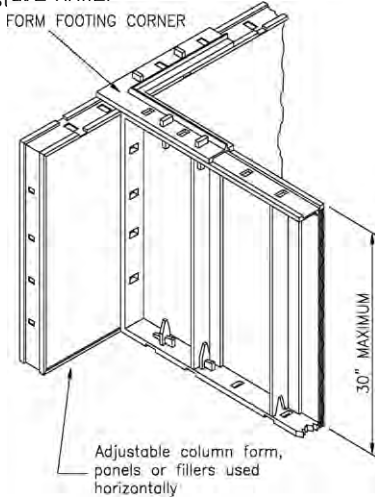

Typical Footing Corner Configuration

All components assemble with standard Wedge Bolts.

The Stake Plate is also designed to accommodate wood forms. It has two nail holes for this purpose.

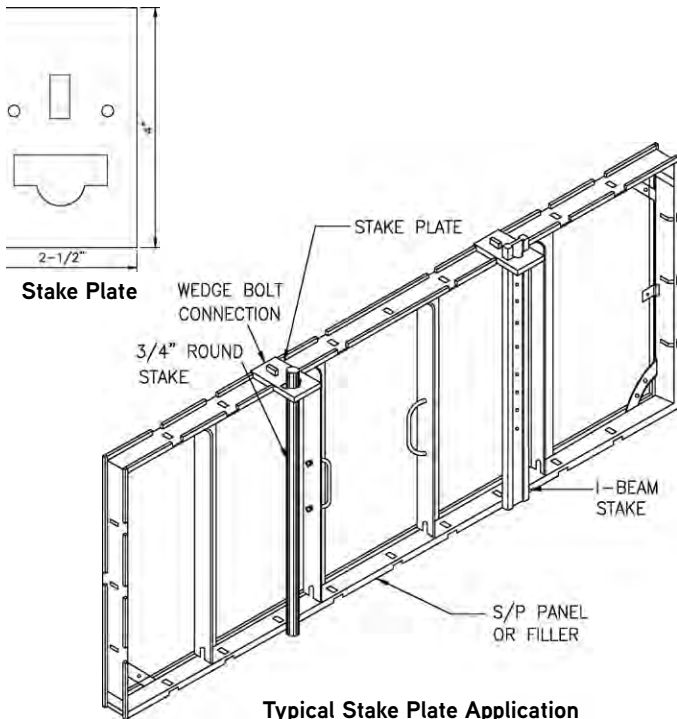

Typical Stake Plate Application

HANDSET ERECTION PROCEDURES

Sill Plates

Panels can be set directly on the concrete footing working to a chalk line or on lumber plates. Plates are recommended because they provide a positive on-line wall pattern and level out rough areas on the footing.

Plates function to preform the position and size of pilasters, changes in wall thickness, locate corners, etc.

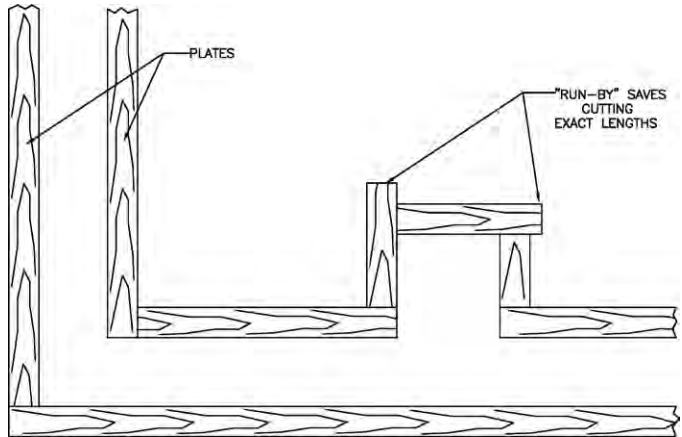

Typical Plate Configurations

Plates extend a level on-line surface for setting grade beam walls which only bear on intermittently spaced footing pads.

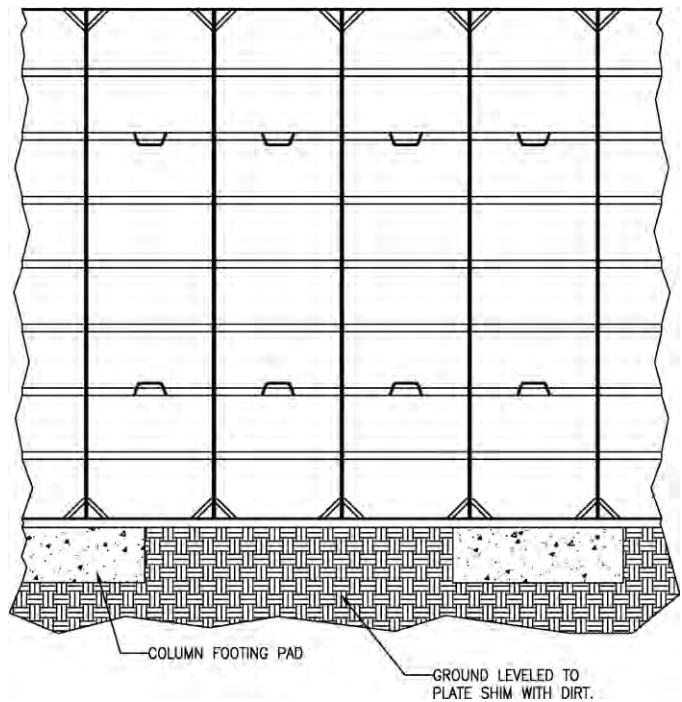

Typical Plate and Footing Pad Configuration

Depending upon the distance between footing pads, it may be necessary to use stakes to align and level the plates.

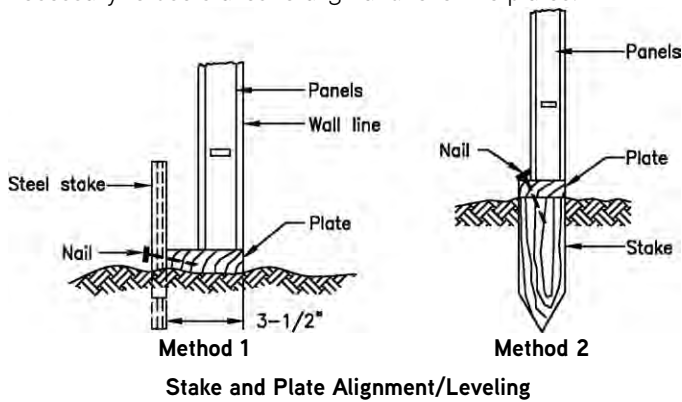

Panels should be nailed down so that they will stay on line. (The panel face should be flush with inside edge of plate.) All panel and end rails contain 2 wide-spaced nail holes. The first panel is nailed at both nail holes. Subsequent panels require only one nail through the leading nail hole relative to panel setting direction.

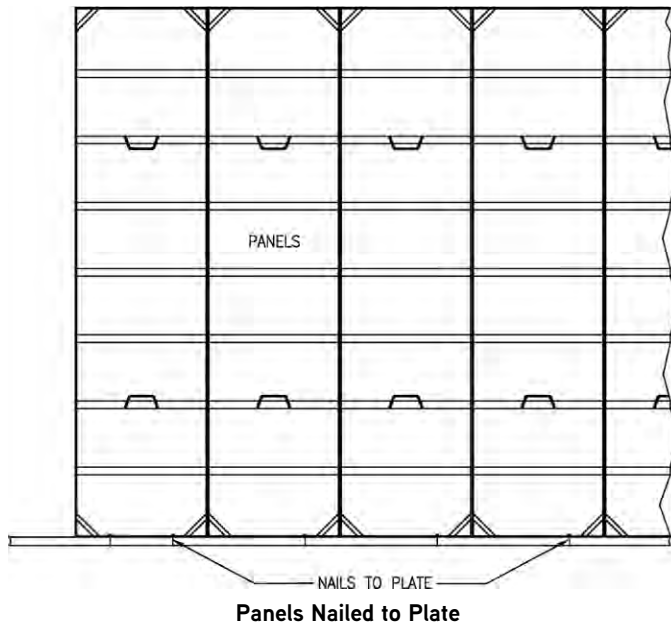

The Wedge Bolt, side rail tie connection is designed with easy-fit tolerances for speed of assembly. These tolerances permit up to 1/4" of slack in a tie spreader action control of wall thickness. Any slack present between opposing forms is removed by lateral pressure during concrete placement. For this reason, panels should be nailed down, aligned and braced on one side of the wall only. The opposing forms are then free to pull out any tie slack without affecting alignment.

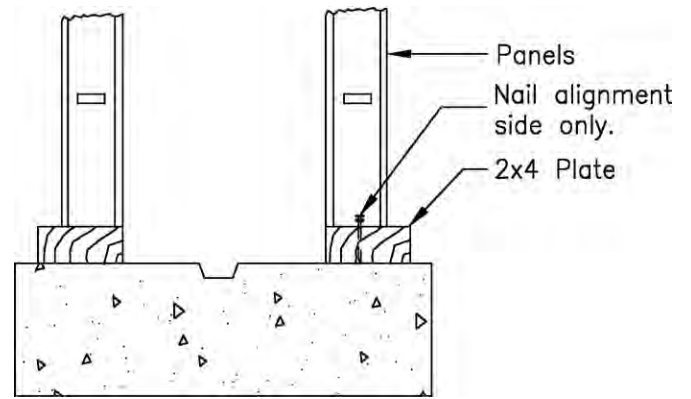

A double thickness plate can be utilized to gain a small amount of extra form height, as an example, an 8' panel setting on a double plate will form an 8'-3" wall. This method is much easier than attempting to nail wood on top of the form.

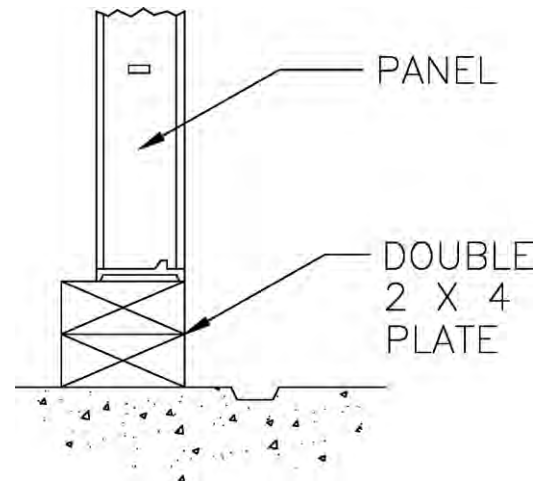

Erection Procedures

There are several panel erection sequence variations. While some applications offer a choice, the job application often dictates the best method to be used. In practically all instances, it is recommended to start at a dimensionally positioned detail such as a wall corner or pilaster. This will ensure that not more than one filler will be required for any straight wall run.

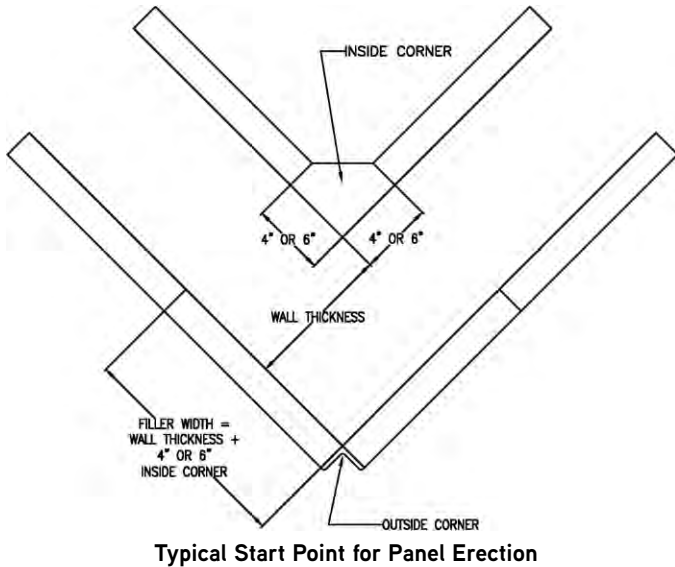

For light construction foundations where reinforcing steel is not involved, ties can be installed along with both form sides in a single, coordinated sequence. If a wall corner can be selected as a starting point, erection procedure is as follows:

First, connect an Outside Corner Angle to the two proper width adjacent fillers and set the inside corner in place.

The width of the outside corner fillers is predicated by the wall thickness plus the face dimensions of the inside corner. For example, the outside corner fillers for a 10" wall utilizing a 6"x6" inside corner would be 16" wide. This procedure lines up opposing form panel joints for tie placement.

After two or three inside and outside panels along with ties are installed in each direction, the whole assembly should be plumbed and braced. A leveling shim should be used if needed.

The progressing work cycle for installing each pair of opposite panels along with accompanying ties is illustrated in these five steps:

Step #1

Position connecting Wedge Bolts with approximately half of their shaft length projecting through the side rail slots at the prescribed tie positions (both opposing panels).



Step #1

Step #2

Place ties over ends of projecting Wedge Bolts.

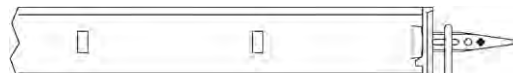

Step #2

Step #3

One at a time, position the next pair of opposing panels in line with the tips of the protruding Wedge Bolts and immediately follow up with Step #4 and #5.

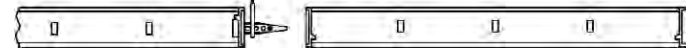

Step #3

Step #4

Shove remaining length of connecting Wedge Bolts into the adjoining side rail slots.

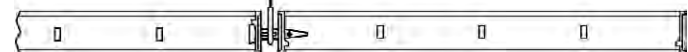
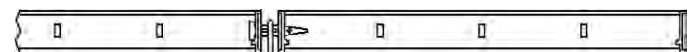

Step #4

Step #5

Move newly positioned panel to close gap between side rails (gap left at Step #4). Insert Wedge Bolts and tighten to a closed joint position. They should not be hammered down excessively.

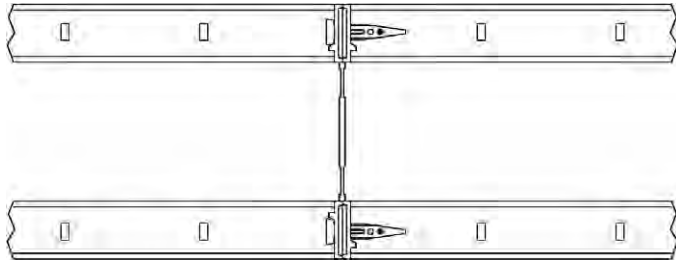

Step #5

Walers should be installed as soon as enough panels are erected to cover the waler lengths to be used. Likewise, alignment bracing should be installed immediately following the installation of each length of waler. Nailing the bottom panel rail on the alignment form side also takes place immediately after Step #5.

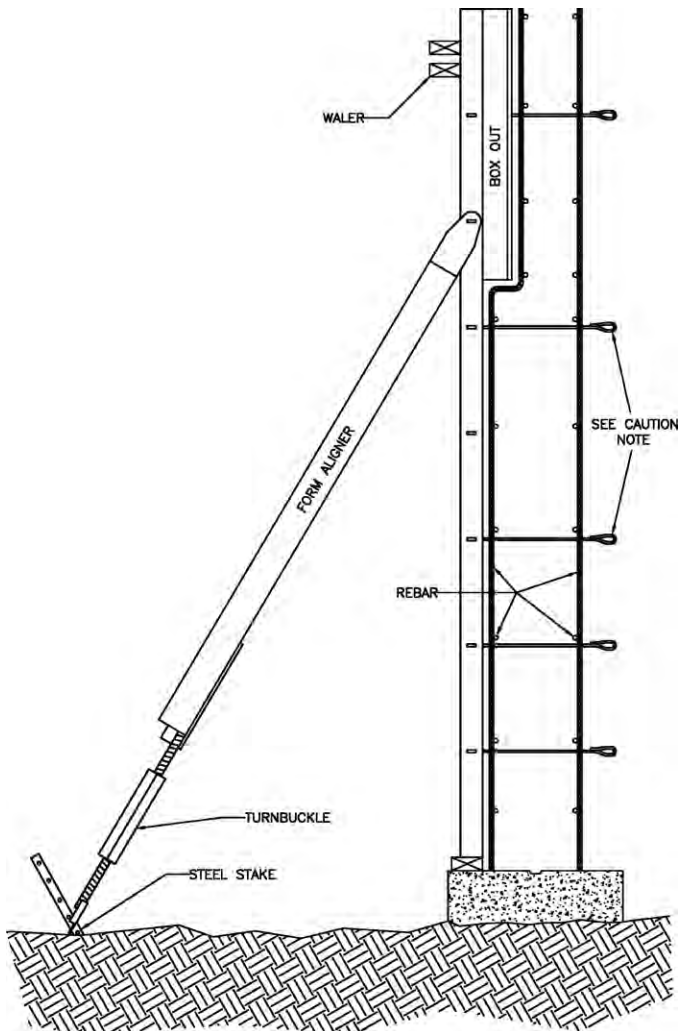

Typical Alignment Brace Installation

Carpenter crews very quickly get the feel for erecting panels and will soon innovate procedure variations that work best for them.

Foundation walls for heavier commercial and industrial construction usually require that one form side of a wall be erected first. Some of the reasons for this procedure are: rebar placement and tie-off alignment to form face, brick ledge and other boxouts to be framed in the wall. Normally, the first wall side set will incorporate all necessary aligning walers, strongbacks and form aligners for final wall alignment. Ties can be installed either with the first form side set or when the opposing panels are set.

CAUTION: When ties are installed with the first form side, their protruding length is vulnerable to accidental bending damage. Replace any ties that are bent through their breakback flat or breakback notches.

Sloped Footings

When footings are slightly sloped and particularly where the top of wall elevation is also sloped, it can be advantageous to erect panels perpendicular to the angle of slope. Where the sloped form must connect to plumb forms, the transition can be accomplished by building a wedge-shaped filler utilizing filler angles and the appropriately cut 3/4" plywood.

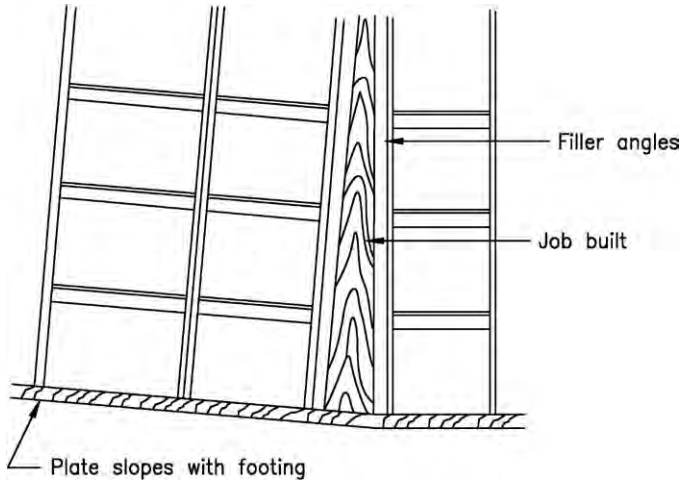

Typical Sloped Transition to Plumb Forms

Most often, panels are erected level to the direction of slope. A wedge-shaped, job-built filler under the forms keeps the form joints vertical and the side rail slots and dadoes lined up. If the fill-in wedge tapers to exceed a 12" build-up, panels should step down at 12" side rail increments.

The job-built, fill-in wedge must be properly braced at 12" side rail increments to minimize the height size of wedge-shaped filler to withstand the concrete pressure. Depending upon specific conditions, the anticipated pressure may warrant waling with additional ties through the wedge-shaped, job-built form.

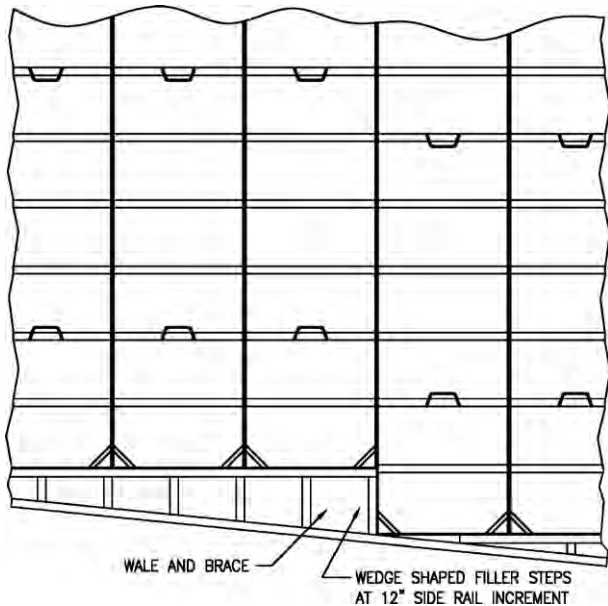

Typical Sloped Filler Under Plumb Forms

Stepping Forms

Form Wedge Bolt connections match 6" or 12" increment steps that occur in footings. 12" increments can include properly installed panel ties due to adjoining tie dados. When 6" increments steps occur, side rail dados do not join, hence, if a tight form joint is required, flat ties can be installed in the half tie slot clearance of one side rail dado. Panel ties can be used at a single dado slot as long as tight form joints are not critical.

The 2" steel fillers and 4" step fillers have connecting bolt slots every 2", and can be used to step forms in any 2" increment. For other than 6" or 12" increments, it is necessary to use separate Wedge Bolts to connect either form side of the filler.

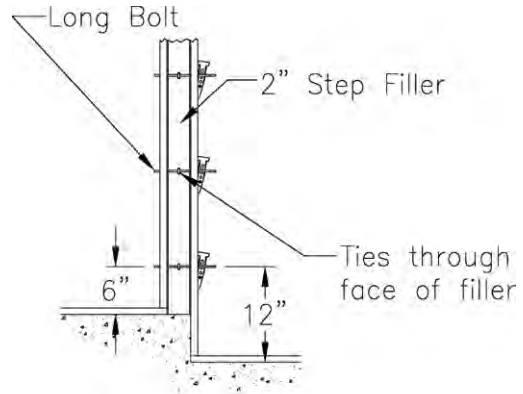

Typical Step Forming with Panel Ties or Flat Ties WITH PANEL OR FLAT TIES

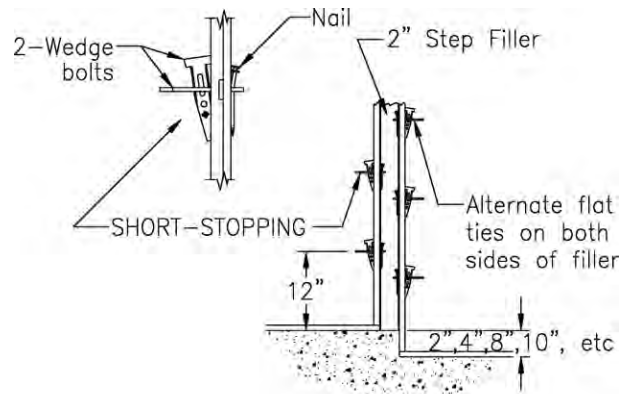

Flat Ties Only Typical Step Forming with Flat Ties

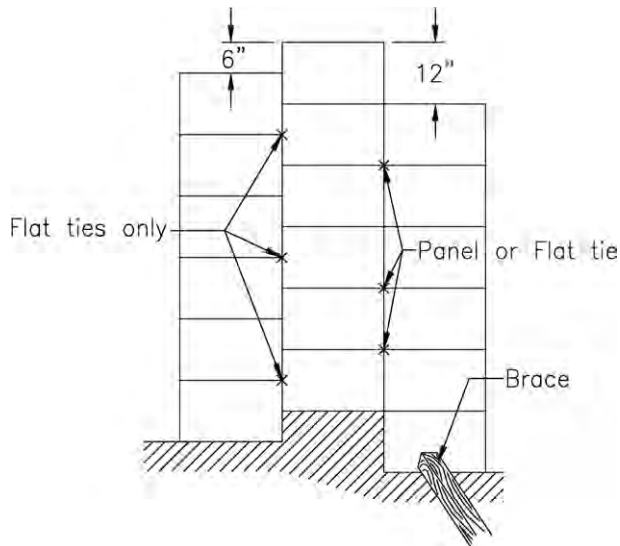

Stepping Steel-Ply in 6" or 12" Increments

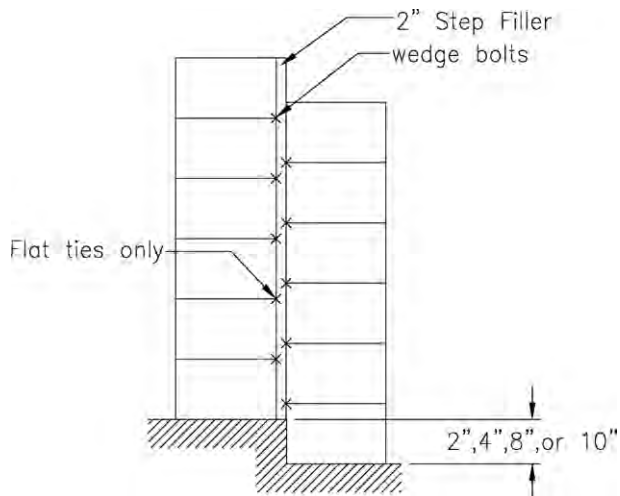

Stepping Steel-Ply in 2', 4", 8", or 10" Increments

Forms can be stepped to any odd increment utilizing Filler Angles.

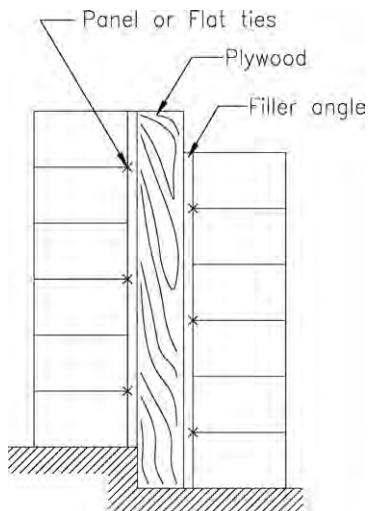

Stepping Steel-Ply in Odd Increments

Bulkheads

Since Steel-Ply panels have plywood faces, bulkheads can be installed using the same methods utilized for securing bulkheads in conventional wood forms.

Additionally, bulkheads can be formed using outside corners and wall thickness size filler or panel.

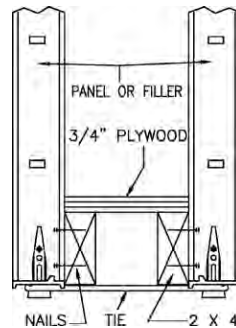

Lumber Bulkhead

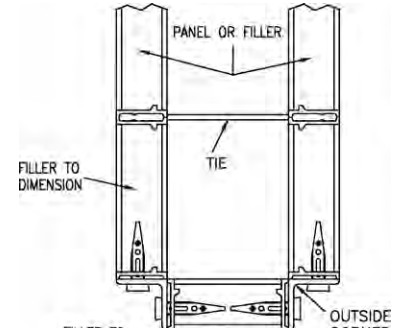

Filler Bulkhead

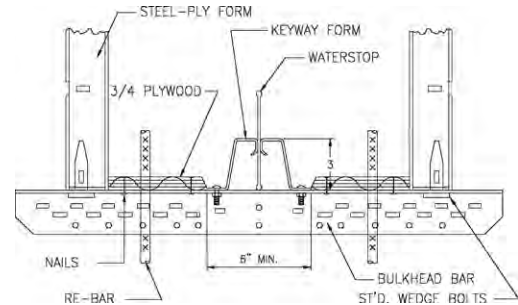

Keyway Bulkhead

Wall Corners

Locking Wedge Bolts are required only at same elevations as wall tie placement. Connections must be through side rail slots adjacent to crossmembers. To avoid position conflict, the lateral Wedge Bolts should insert first through the Outside Corner Angle, so that the tightening Wedge Bolts will bear at the side rail side of each connection. Wedge Bolts should insert from the corner side into the panel.

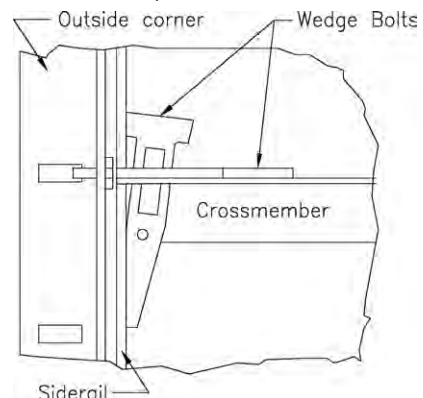

Typical Wedge Bolt Connection at Outside Corner

Intersecting Walls

When the thickness of an intersecting wall is 12" or less, a single panel or filler will span the dimension opposite the wall intersection permitting wall tie placement at both Inside Corner form joints.

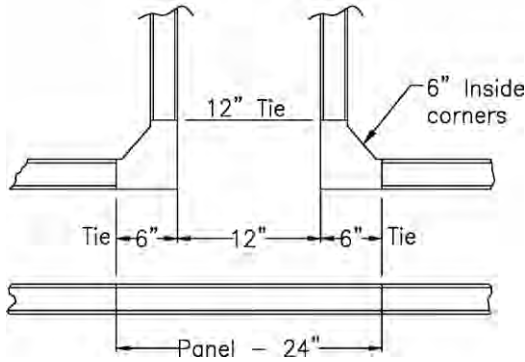

Typical Form and Tie Configuration for Intersecting Walls 12" Thick or Less

If the intersecting wall is 13" to 16" thick, one or two steel fillers may be utilized at either side or both sides of a 2' panel to make up the necessary fill-in form dimension.

As indicated in the sketch, the ties are canted at a slight angle due to their connecting through the tie slots centered in the face of the steel filler.

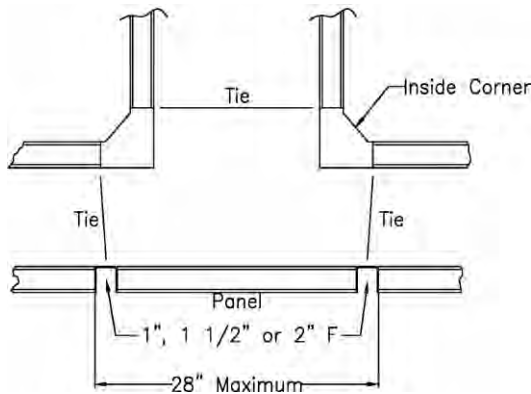

Typical Form and Tie Configuration for Intersecting Walls 13" to 16"

An intersecting wall thicker than 16" can be formed either by utilizing special pre-bent panel ties, or utilizing walers plus bracing to support the form joint where ties are not installed.

The pre-bent special tie method is the recommended way, due to the fact that holding form loads via internal ties is more dependable than the unpredictable compression capacity of external bracing. Also, the load gathered by the waler may overload the adjacent ties.

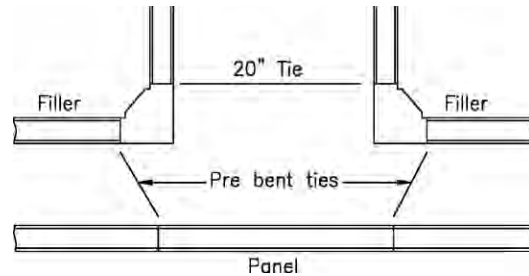

Pre-Bent Panel Tie Application for Intersecting Walls over 16"

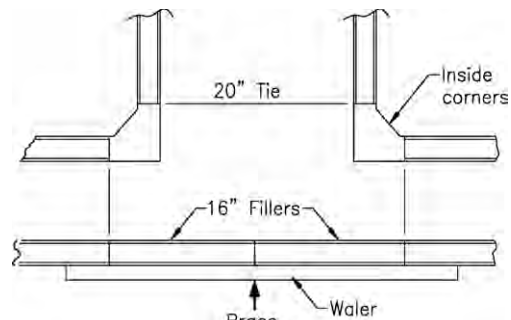

Application Using Walers and Braces for Intersecting Walls over 16"

CAUTION: Adjacent filler widths should be reduced accordingly to prevent overloading tie.

Specific job conditions can obstruct forms on one form side of a wall, such as large diameter sewer pipe that must be poured flush to the opposite form face.

When forms are without opposing tie joints, the floating panel joints must be waled and properly braced.

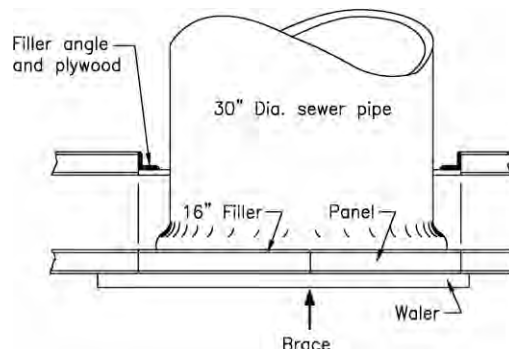

Typical Waler and Brace Configuration for Joint without Tie

Walers

When setting panels utilizing either panel ties or flat ties, walers normally function in a form aligning capacity only. This is in contrast with many job-built lumber methods in which the walers are the main load gathering members to which the wall ties are secured. With the Steel-Ply forming system, the panel ties or flat ties connect directly to the panel side rails and their length terminate at that point. In effect, at each vertical row of ties, the adjoining side rails function as vertical steel walers; hence, the horizontal add on waler functions as an aligner only.

For walls up to 8' high utilizing one panel lift and with a setting plate secured to the footing only one aligning waler either 6" or 18" from the top on the alignment side of the wall is required. The opposite form side gains alignment through the appropriate length wall ties.

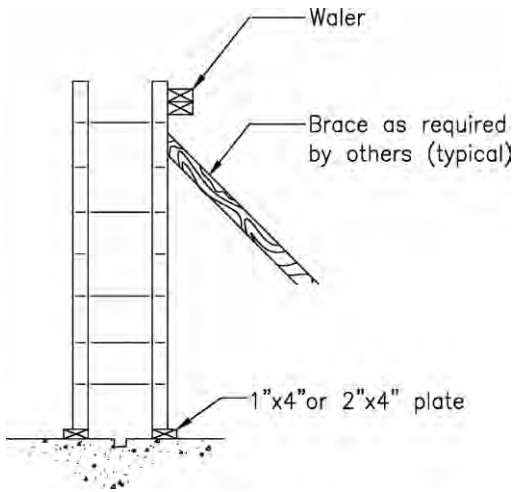

Typical Waler, Brace and Tie Positions for 8' Forms

The Waler Tie and Z-Tie Holder are available in two lengths to secure either double 2x4 or double 2x6 lumber walers. This method offers the flexibility of placement by inserting the Waler Tie in side rail dado slots for connection with Wedge Bolts, or it can be positioned at a tie Wedge Bolt connecting point between the outside of a side rail and the Wedge Bolt.

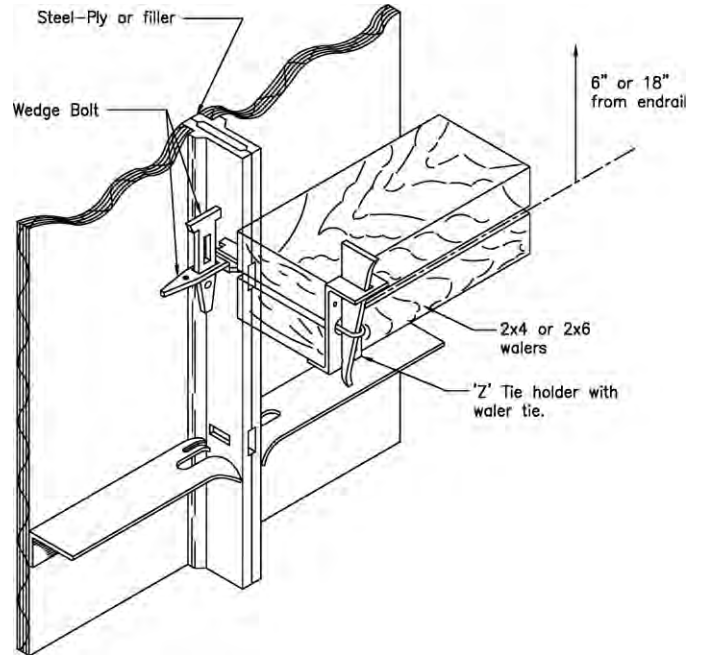

The One-Piece Waler Clamp offers the one-piece, hook-on advantage at any available adjoining side rail connection slot, that is not reserved for a panel tie connection, plus the unique advantage of functioning with two 2x4s or a single 2x4. Both 2x4s go over the top of the clamp and are wedged tight to the side rail.

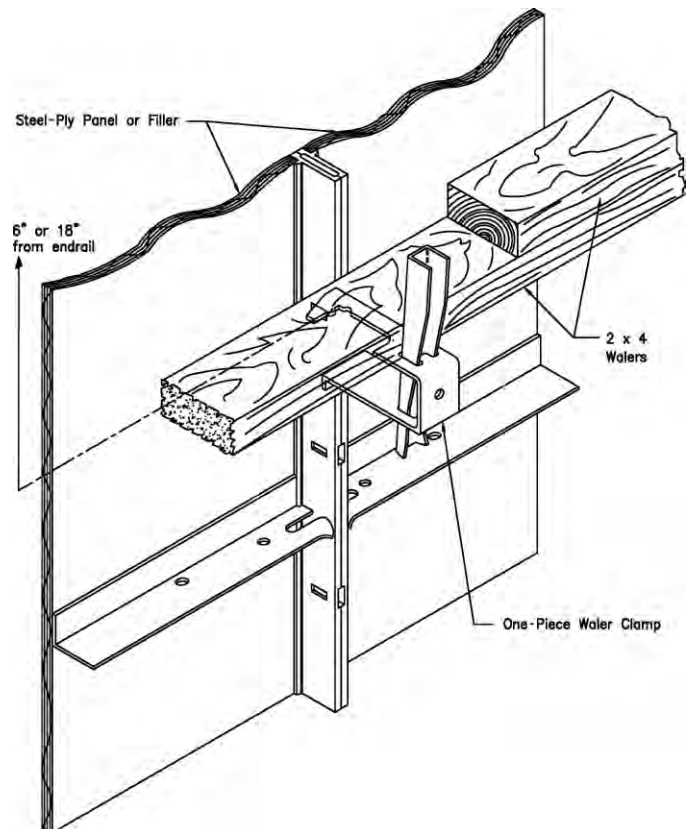

One-Piece Waler Clamp Installation

Strongbacks

Strongbacks are vertical alignment members that are placed at 90° to walers. The strongbacks are used to align the walers and are commonly placed at 8' O.C.; actual placement spacing is determined by specific job conditions.

Materials for making up strongbacks can be doubled 2x4s, 2x6s or 2x8s, depending on stiffness required to satisfy specific applications.

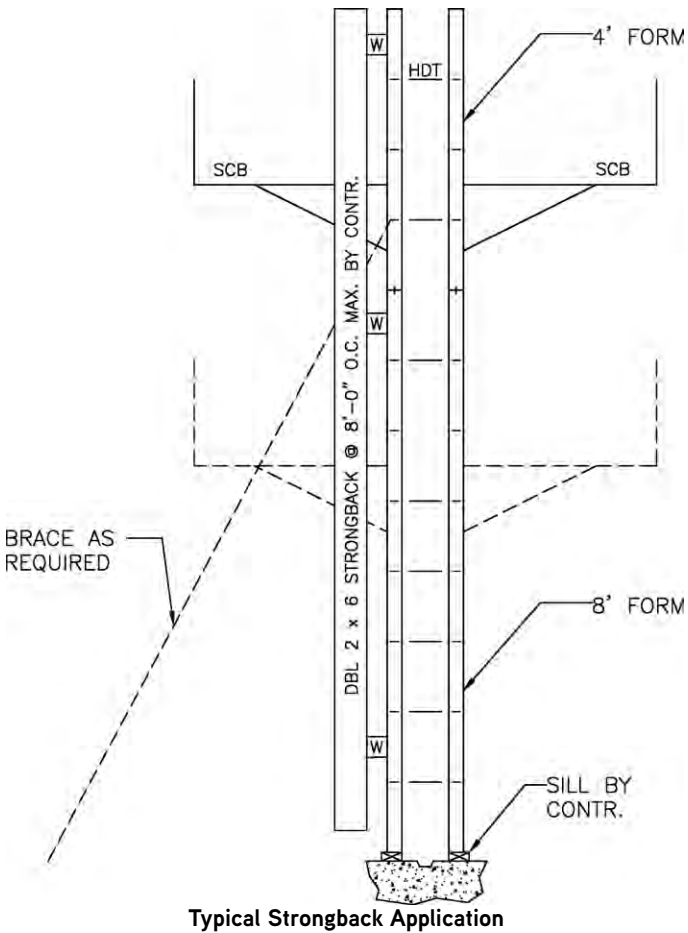

Typical Strongback Application

Strongbacks are attached using either Strongback Ties with Z-Tie Holders or J-Strongback Hooks. Strongback ties secure at a side rail's Wedge Bolt connection, while the J-Strongback Hook simply hooks over one member of the lumber waler. When Strongback Ties are used in conjunction with lumber walers and strongbacks, the Strongback Tie can eliminate the need for a Waler Tie at that point.

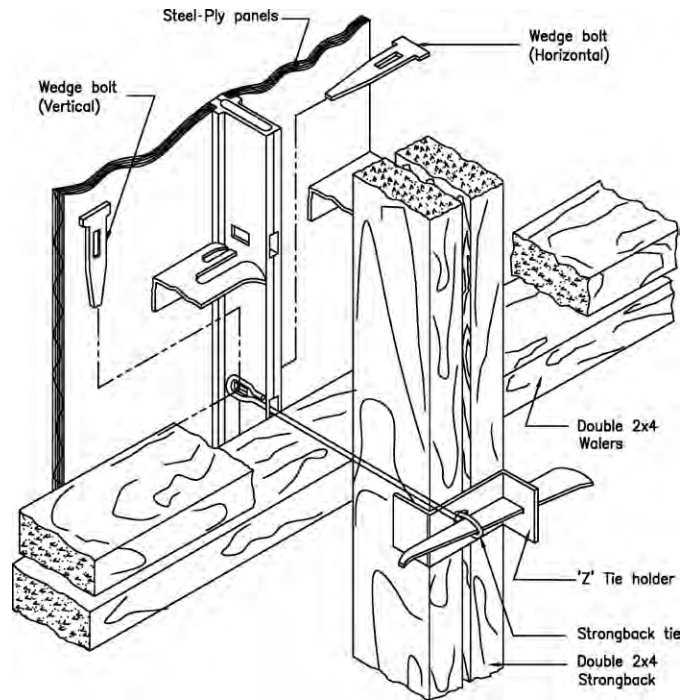

Typical Strongback Installation with Strongback Tie and Z-Tie Holder

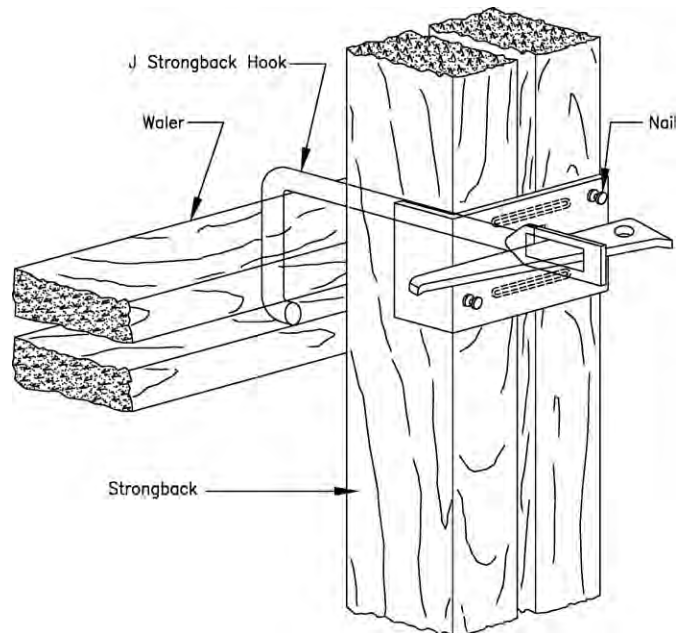

Typical Strongback Connection to Waler with J-Strongback Hook

Strongback ties have loops in the same plane as compared to Water Ties which have loops perpendicular to each other.

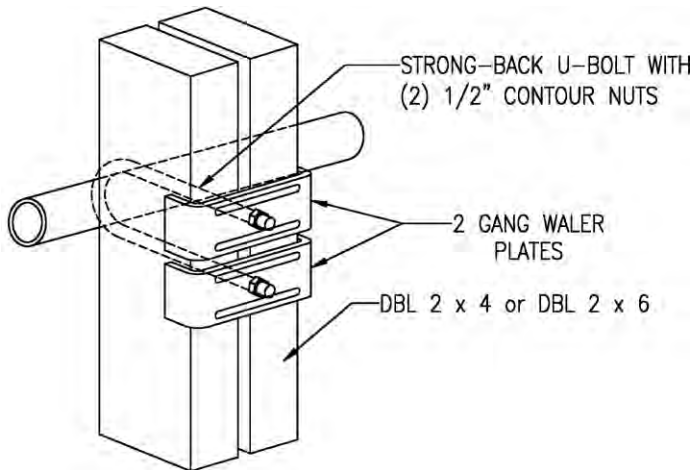

Typical Strongback Installation with U-Bolt and Pipe Waler

Strongbacks for pipe waled forms are attached with a strongback U-Bolt. Either double 2x4 or double 2x6 lumber can be used.

Stacking Forms

Normally, panels should be stacked on top of panels and fillers over corresponding filler widths.

For best panel face alignment, place hardware in first and third wedge slots on each panel end rail. Placement of hardware in the middle dado slot occurs when a tie is required. For a more positive connection, always install vertical Wedge Bolts point down with the locking Wedge Bolt at the underside.

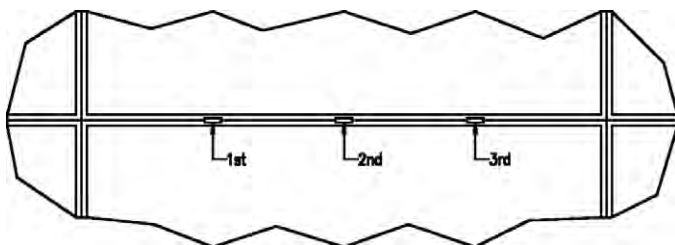

End Rail Dado Slots for Wedge Bolts

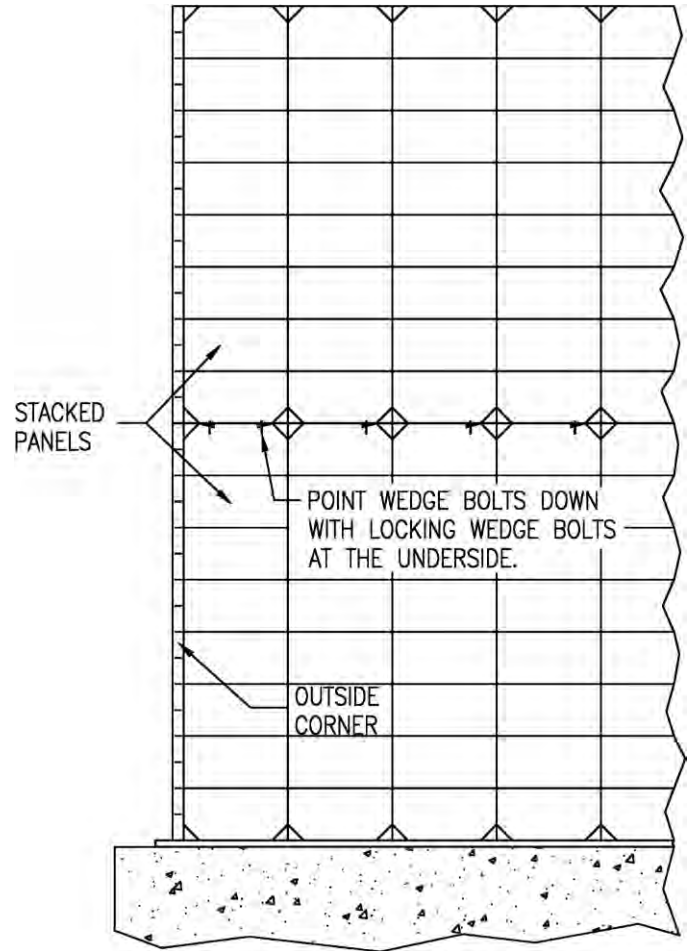

Typical Wedge Bolt Locations for Stacked Forms

It usually is best to start erecting stacked panels at a corner. On the first panel from the corner, install hardware in the first and third end rail Wedge Bolt slots. From that panel, most applications will require only one Wedge Bolt connection on the top panel to the one below it. That one connection should always be through the third end rail slot as measured from the last panel set.

Panels at both form sides of a wall should be the same size so that their horizontal stacking joints are opposite each other. This facilitates placement of wall ties at the stacking panel joint when required, and assures that required vertical joint tie locations are available at both wall sides.

Wall heights made up of two or more panels stacked bottom rail to top rail require waler alignment as close as possible to the stacking panel joints. 6" down from the top rail of each lower tier panel is the most practical position. That position permits the waler to be in place for preliminary alignment, and bracing prior to placement of the next tier of panels. When the top tier and bottom tier forms are either 6' or 8' panels, the top of wall and bottom of wall walers may be positioned either 6" or 18" from the corresponding end rails depending

on preference location for scaffold brackets or other accessory hardware. When convenient, the top waler should be located as close as possible to the top of concrete pour. Alignment walers are only required at one side of the wall.

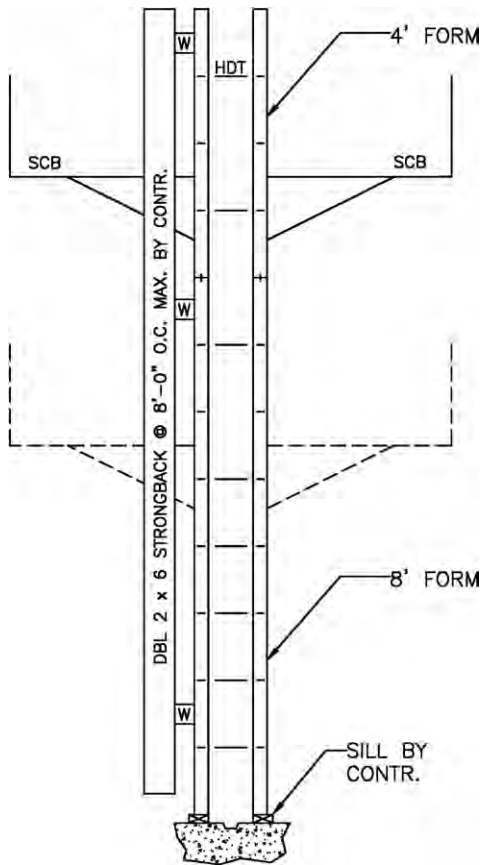

Typical Strongback and Waler Configuration for Stacked Forms

Horizontal panels may be stacked on top of vertical panels. In most applications, the same length horizontal panels should be installed at opposite form sides of a wall. The horizontal panels should be selective lengths so that vertical form joints occur where required for hardware and tie connection to vertically stacked fillers, pilaster forms, corners or any other detail that warrants a common vertical form joint.

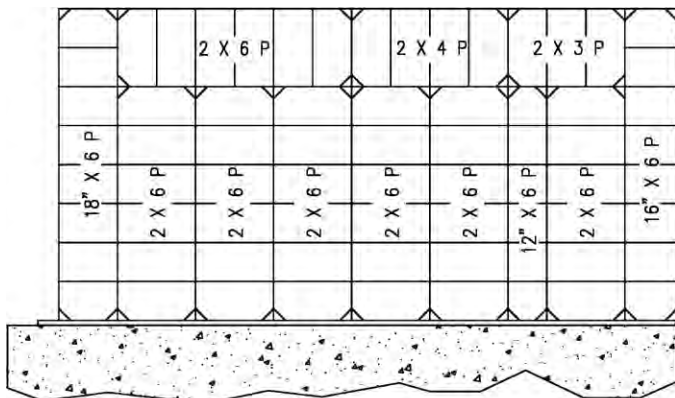

Typical Application Horizontal Panels Stacked on Vertical Panels

Second Lift Forming

There are several methods to support forms in a handset operation on top of a previous wall pour. One method is to utilize concrete embedded anchors which were secured to the prior pour formwork. After removal of the first lift forms, a timber is bolted to the anchors. This provides a ledge which will support the next lift of formwork. If the ledge is located an inch or two below the previous pour, good alignment between the subsequent pours can be achieved.

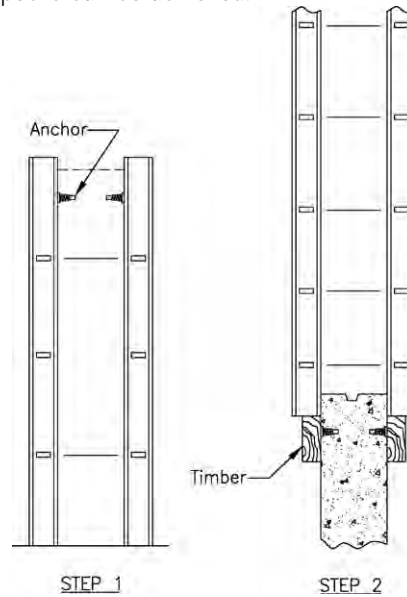

Second Lift with Supporting Lumber

Another method is to leave the top tier of the previous forms in place undisturbed. The second lift of forms is then erected and supported as a continuation of the first lift forms.

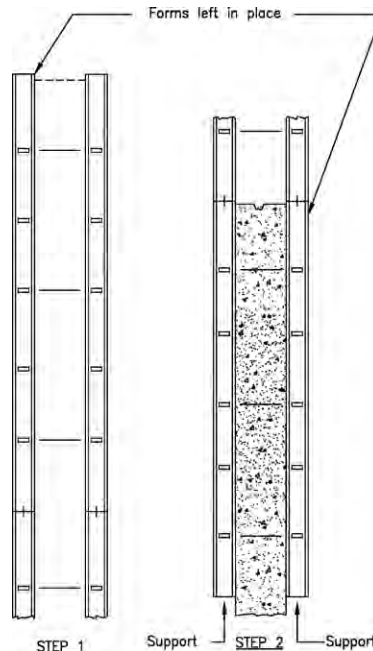

Second Lift with Form Support

Adjustable Shear Wall Brackets

We highly recommend the use of Symons Adjustable Shear Wall Brackets for vertical support of ganged forms. The bracket is attached with an insert that does not require drilling a hole through plywood.

The threaded adapter plug is nailed to the plywood face and the insert is screwed on to the plug. After concrete is placed, and the form stripped, the plug is unscrewed. A fully threaded high strength $\frac{3}{4}$ " bolt attaches the Adjustable Shear Wall Bracket to the insert. This bracket has a vertical adjustment range of over 2".

The Adjustable Shear Wall Bracket Safe Working Load rating when mounted flush to surface in 3500 psi concrete is 3000 lbs at a 3:1 Safety Factor.

NOTE: On applications using form liner, consult the Symons Branch Engineering Department for proper use of the Adjustable Shear Wall Bracket.

CAUTIONS:

1. Remove forms before removing brackets
2. Do not attach bracket to irregular surface such as concrete formed with textured form liners.
3. Do not use Taper Ties or She-Bolts as gang supports.

Anchor Inserts

Dayton expanded coil insert, galvanized F-57, $\frac{3}{4}$ "-10UNC ferrule, $4\frac{5}{8}$ " long.

Attach insert to form face utilizing the Setting Plug (Dayton threaded plastic plug F-74 with $\frac{3}{4}$ "-10 UNC threads.

Anchor Bolts

$\frac{3}{4}$ "-10 UNC x 1 $\frac{1}{2}$ " long zinc-plated, Grade 5 bolt with full length threads.

Guide Bolts

The Guide Bolt is a separate item, and must be ordered when using the Adjustable Shear Wall Bracket with Steel-Ply forms.

Guide Bolts convert Adjustable Shear Wall Brackets into special function brackets for support of Steel-Ply gangs.

The bracket head plate has a $\frac{5}{16}$ " x $\frac{3}{4}$ " slot for attaching the Guide Bolt.

The shape of the Guide Bolt is symmetrical, so any way it is mounted, a 45° slope helps gravitate the gang into aligned position with the previous pour.

An 8d nail secures the threaded plastic Setting Plug, F-74 P.C. D60426, to the form face.

F-57 P.C. D40561 - $\frac{3}{4}$ "-10 UNC x 1- $\frac{1}{2}$ " Expanded Coil Insert is then attached to the form face by threading onto the Setting Plug.

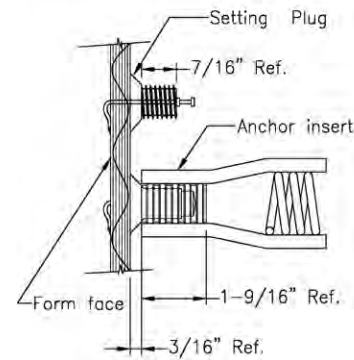

Anchor Insert Installation

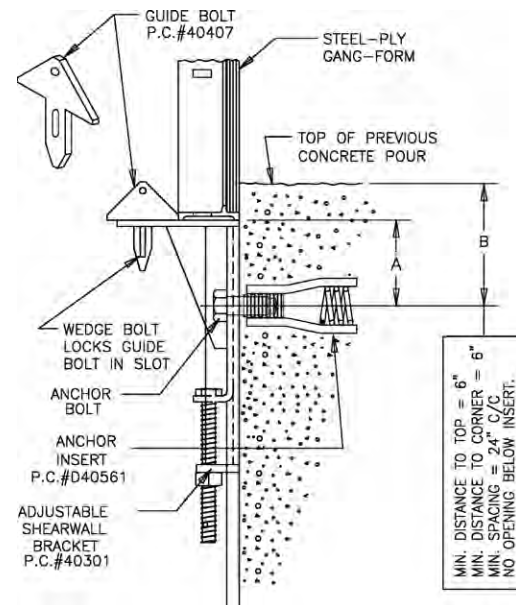

Adjustable Shear Wall Bracket Installation

The Adjustable Shear Wall Bracket elevation adjustment range is $2\frac{3}{8}$ ", or from $3\frac{1}{2}$ " to $5\frac{7}{8}$ " at Dimension A. Dimension B usually includes a desired amount of previous pour overlap, but never less than the minimum $3\frac{1}{2}$ " dimension at A.

For handset applications, do not use the Guide Bolt. Secure appropriately sized lumber to the top plate of the Adjustable Shearwall Bracket and set and secure forms on the lumber.

Multi-Shear Wall Brackets

The Multi-Shear Wall Bracket is used for support of wall gangs. The Multi-Shear Wall Bracket is adjustable from 3½" to 5⅞", with a total vertical adjustment of 2⅜". Safe Working Load Rating when mounted flush in 3,500 psi concrete is 3000 lbs at a 3:1 Safety Factor.

Attachment of Multi-Shear Wall Bracket is achieved using the same Anchor Insert and Anchor Bolt used for the Adjustable Shearwall Bracket (see previous page).

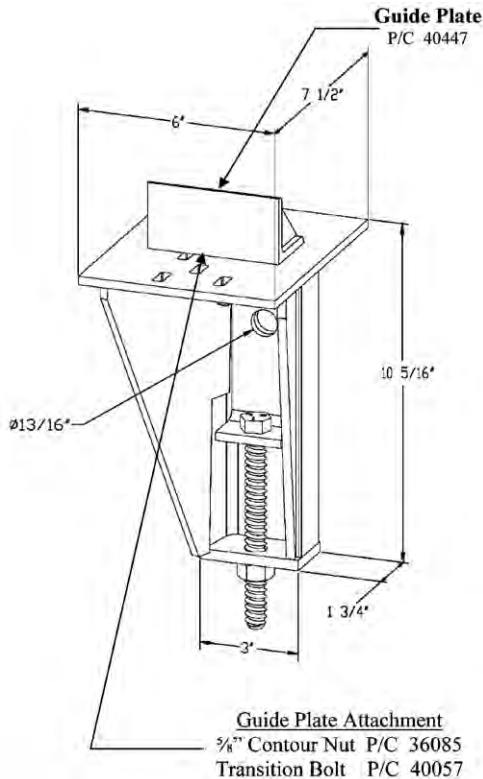
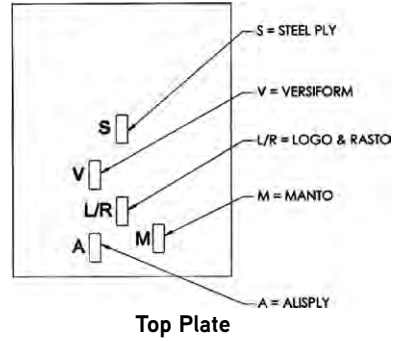

Multi-Shear Wall Bracket with Guide Plate

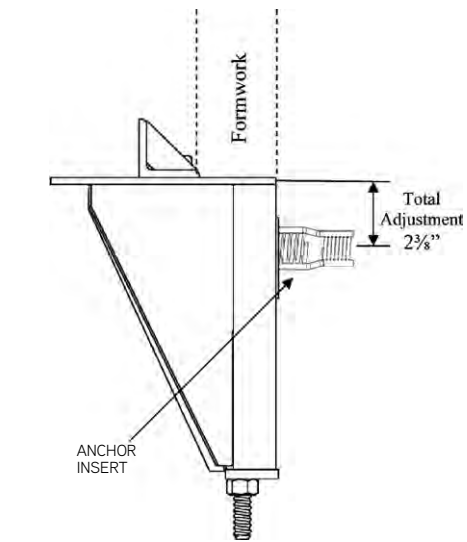

Typical Multi-Shear Wall Bracket Installation

CONVENTIONAL PANEL TIE GANG FORMING

Steel-Ply panels and fillers can be connected in large interconnecting units (gangs) in order that the units may be set and stripped with a crane. Gang form ties are much the same as heavy duty panel ties, with the difference being the extended overall loop-to-loop length of the gang form ties. The loop of the tie is held in position behind the forms by use of the Gang Form Bolt, twist the tie to break it inside of the concrete, and remove the tie end. With the tie ends removed, the ganged forms can remain assembled for setting and stripping.

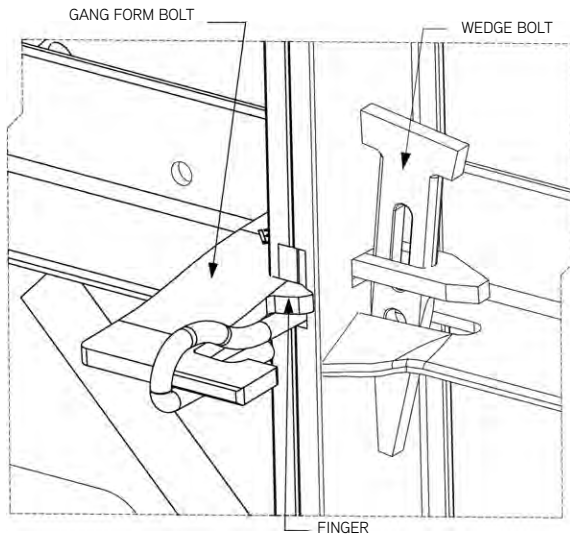

Gang Form Tie Installation

NOTE: The Gang Form Bolt "finger" always goes on the side of the tie with the hump part of the loop, opposite of the welded side.

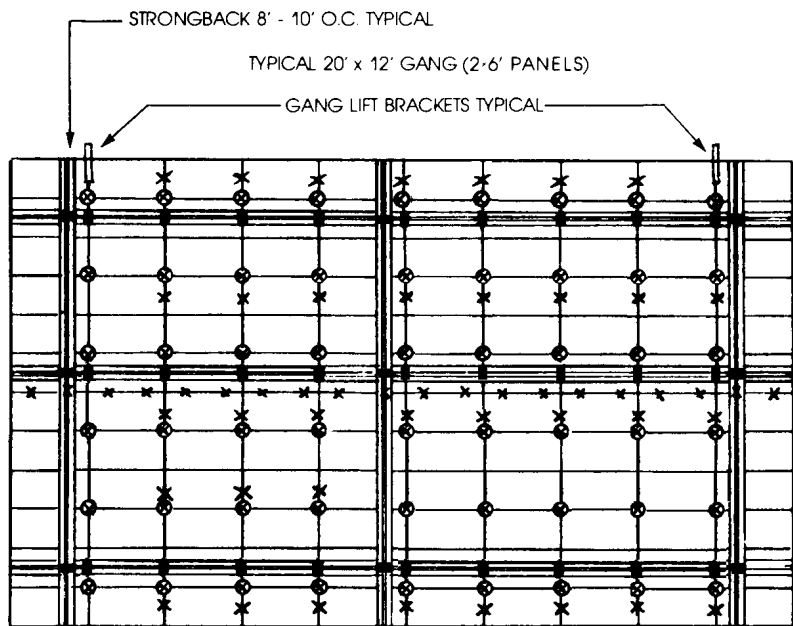

Typical waler and Strongback Configuration for Steel-Ply Gang

Assembling Gangs

Ganged forms can be assembled by laying the forms on any reasonably flat surface. 2x4 or 2x6 lumber can be laid out to fall under the horizontal joints of the panels. The panels are placed on the lumber with the plywood faces down, and the hardware is inserted in the panel side rails. A Wedge Bolt connection is made 6" from the corners of all panels and 6" from the midpoint of 6' or 8' panel side rails.

Walers and strongbacks for straight gangs are usually 2x4 lumber, although 2x6 and 2x8 lumber can be used. The combined depth of the lumber for walers and strongbacks should not exceed 12". As an example, double 2x4s might be used as walers and double 2x6s or 2x8s used as vertical strongbacks. Gang form ties connect directly to the panel side rails with Gang Form Bolts; therefore, walers and strongbacks are used for alignment of panels only. Since the walers and strongbacks are not used to contain the concrete pressure, very few are required as compared to job-built lumber forming methods. Walers and strongbacks should be located so they do not interfere with tie placement. Dado slots are provided at the rear of the panel side rails and are located at 6" and 18" from the top and bottom of panels for hardware attachment.

- ✕ WEDGE BOLTS TYPICAL
- ⊗ GANG FORM BOLTS · HEAVY-DUTY TIES TYPICAL
- WALER ATTACHMENTS TYPICAL
- STRONGBACK ATTACHMENTS TYPICAL

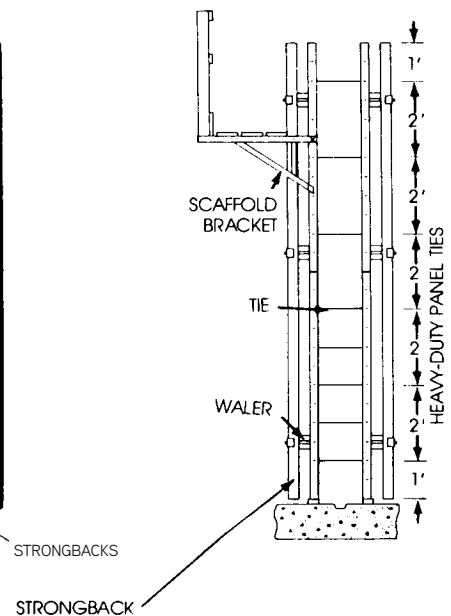

As an example, assume that a gang with a 12' height will be assembled with 6' panels. Panels align horizontally by attaching 8" gang water rods at the 1'-6", 6'-6" and 10'-6" elevations and place double 2x4 or 2x6 walers across the panels at these locations. The walers are secured with Gang Waler Plates, and double 2x6 vertical strongbacks are attached to the walers with one 14" Gang Waler Rod and two Gang Waler Plates.

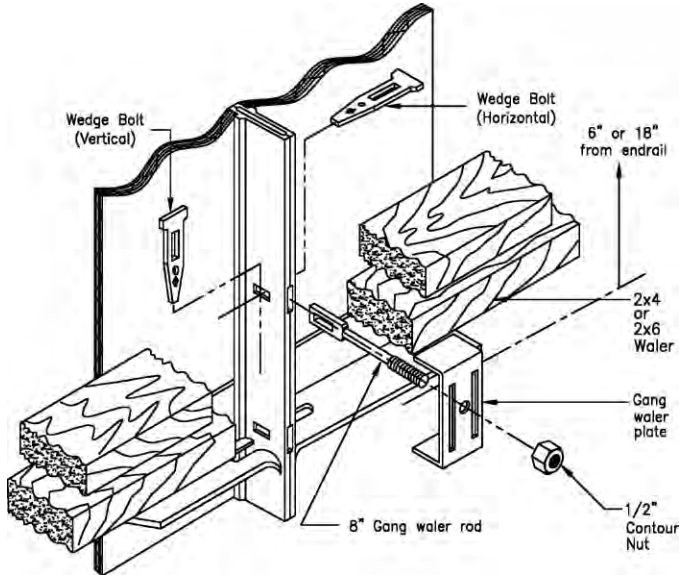

Typical Water Attachment to Gang

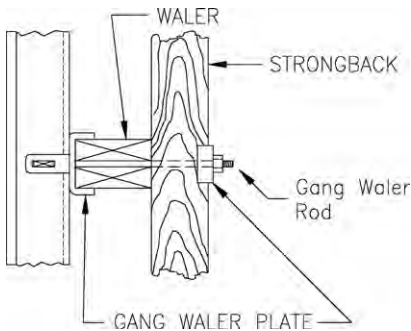

Waler and Strongback Attachment with Gang Waler Plate

An alternate method of attaching the vertical strongback is with a 12" J-Strongback Rod, 2 L-Washers and a 5/8" contour nut.

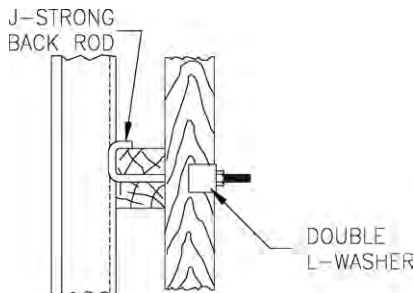

Waler and Strongback Attachment with J-Strongback Hook and Double L-Washers

Gang Form Ties

Ties are inserted through the side rail dado slots after two opposing ganged units are in place. The tie is secured at each end with a Gang Form Bolt. If it is inserted right to left, the nose goes under the tie. If, after latching the tie at one end, it is found that the opposite tie end is out too far from the form to insert the Gang Form Bolt through the tie loop, do not try to hammer the tie inward. It means that the two gang forms are too close to each other and that one of the forms should be moved outward. If a hammer is used on a tie end, the weld at the loop on the opposite side can fracture due to the wedging action of the Gang Form Bolt in this opposite tie loop. The best of welds can be hairline fractured without it being noticed (until concrete is placed).

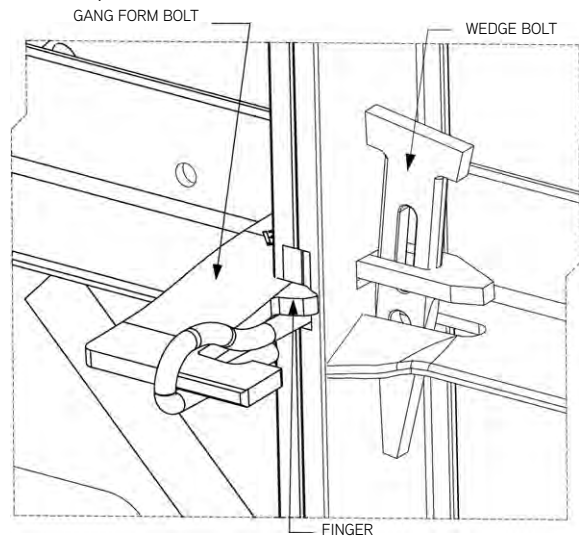

Gang Form Tie Installation

NOTE: The Gang Form Bolt "finger" always goes on the side of the tie with the hump part of the loop, opposite of the welded side.

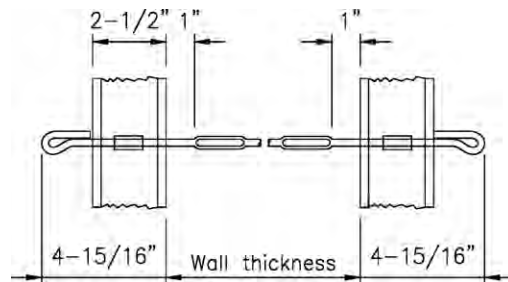

Gang Form Tie

Cone Ties

Cone Ties may be used with ganged forms with the following two qualifications:

1. When cones are required at both ends of the tie, only one wall side can be gang formed, and the ganged side must be in position first.
2. If the tie has a cone on only one end, and the wall thickness exceeds 5" plus the length of the cone, both wall sides may be ganged. The wall side not requiring the cone must be positioned first. The ties are then inserted through the form face up to the opposite side cone. After the opposing gang is in place, the ties are moved back into the tie dado slots and gang form bolts are secured.

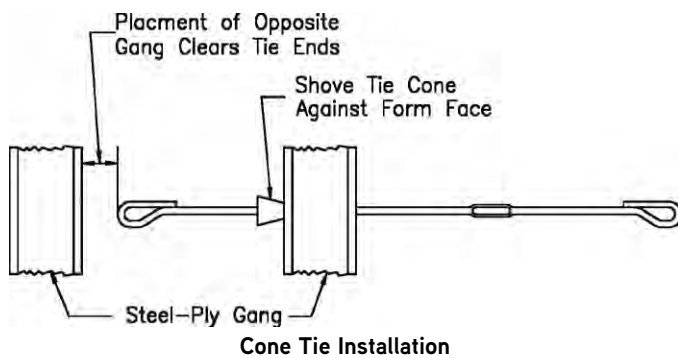

Form Alignment

Alignment should be installed on one side of a wall only. It is neither necessary nor desirable to align both sides. Alignment on both sides can "squeeze" the wall thickness causing the condition described previously. Also, it can interfere with proper load distribution on the ties. Generally, it is best to set and align one side, set the other using spacers and position ties at top and bottom before securing the other ties.

NOTE: Refer to the Form Alignment segment in Handset Erection section.

Tie Removal

When the gang is at an elevation above ground, it is recommended that Gang Form Bolts be removed, ties broken back and the gang detached from adjacent forms beginning at the bottom and working upwards. This is a safety precaution which allows the man to get off of the ganged form at the top of the wall before he releases the final hardware and top row of ties. At this time, the crane should be attached to the Gang Lift Brackets.

Curved Walls

2' wide panels will readily form curved walls down to a 15' radius or 30' diameter. Standard fillers can be used to form smaller radius walls. For example, 8" fillers form a 5' radius.

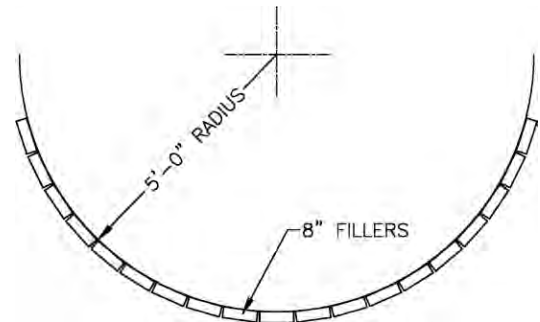

5' Radius with 8" Fillers

The outside forms of a curve or round tank require 1", 1½" or 2" steel fillers at predetermined joint intervals to keep inside and outside panel tie joints opposite each other. This is due to the larger circumference covered by the outside forms.

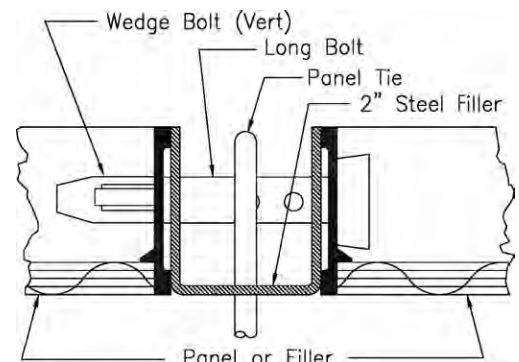

Typical Steel Filler Installation

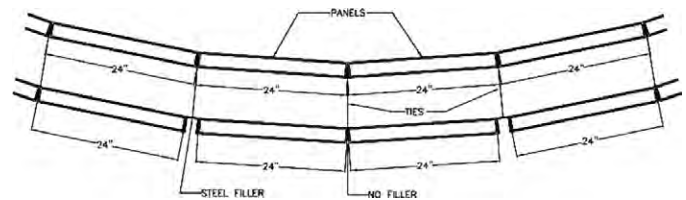

Typical Steel Filler Spacing

Curvature alignment is accomplished by utilizing curved lumber or plywood walers sawed to the exact curve from extra width lumber.

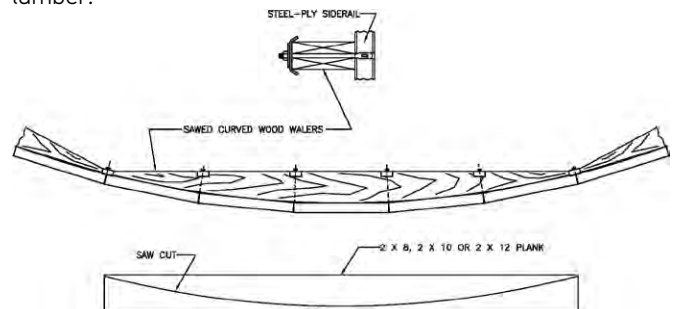

Typical Attachment of Lumber Waler Cut to Curve

Straight double lumber walers may be used to establish a curved surface by utilizing the 8" or 14" Gang Waler Rods, two nuts and two Gang Waler Plates.

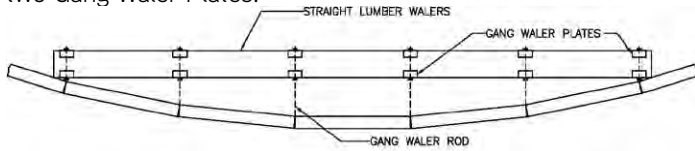

Typical Application of Straight Lumber Waler

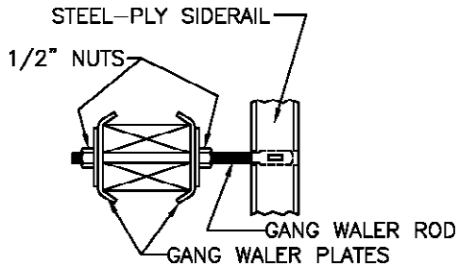

Attachment of Straight Lumber Walers

Steel angles, channels, and pipe can also be custom rolled to required waler curvature.

Custom curved steel pipe and channels are attached to the form with the same connecting hardware methods as straight pipe or channels.

Dimensional lumber such as 1x4s and 1x6s can be installed flat and flexed to the desired curvature. These can be laminated in two or more thicknesses for stiffness, with joints staggered for extended curve continuity.

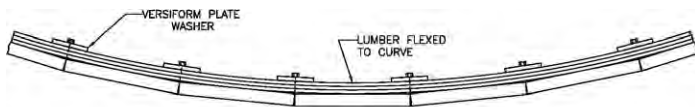

Typical Application of Curved Lumber Waler

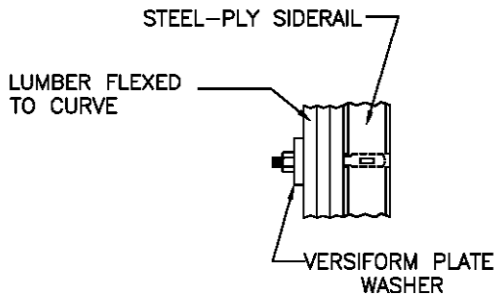

Attachment of Curved Lumber Waler

Curved plates may be made of 2x2 lumber flexed to the required curve. For smaller radius curves, the lumber can be kerfed.

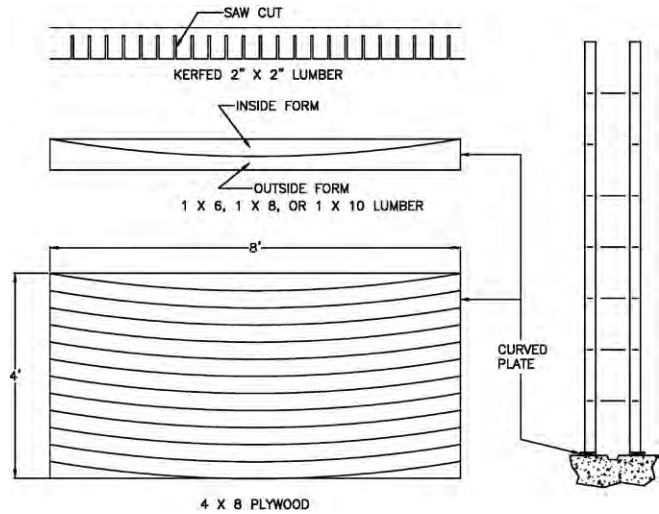

Design and Application of Curved Plates

Curved plates can also be cut from 1x6, 1x8 or 1x10 lumber using one side of the cut for the inside form and the other for the outside form. Small radius plates can be cut from 8' lengths of plywood.

Inside form joints open up at the face joint relative to the directional angle change between adjoining forms. It is recommended that wood strips be inserted in the opening for two reasons: To prevent excessive grout leakage, and to prevent the natural tendency for form joint Wedge Bolts to pull panels toward a straight line. Joints without wood strips also increase the need for more substantially curved walers or more frequent bracing to hold the curve. On larger radius curves, the face gap may be less than 3/16" and continuous fill-in strips would not be practical. Short wood spacer shims at approximate 2' intervals would be sufficient to hold the angle between adjoining forms.

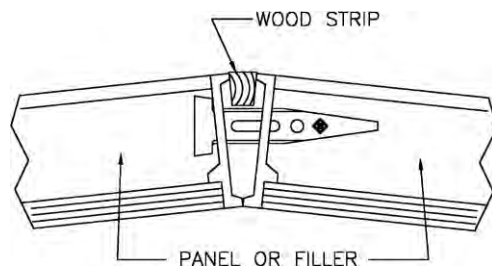

Installation of Wood Strips for Curves

Curved Gang Forming

Curved ganged Steel-Ply formwork is similar to the formwork discussed previously. There are a few basic differences, but the use of Steel-Ply makes curved wall forming a relatively simple matter when compared to job-built curved forms. Forms for curved walls are usually assembled in the vertical position for the first pour and moved for subsequent pours because it is easier than building a curved template and assembling the panels on the ground.

As with hand-set curved walls, the small 1", 1½" and 2" steel fillers are used on the outside forming to keep the inside and outside panel joints reasonably opposite each other. However, where the longer end gang ties through the steel fillers will be used, the loop of the tie with a Gang Form Bolt cannot be secured. The nose of the bolt will not go through the grip distance of two side rails and the filler. The tie loop is secured with a Gang Form Adapter Sleeve, a Long Bolt and three Wedge Bolts. When stripping, remove this hardware and then twist the tie end loose as is done when using the Gang Form Bolt. The 1", 1½" and 2" fillers are held in the gang with Long Bolts at side rail slots above and below tie locations.

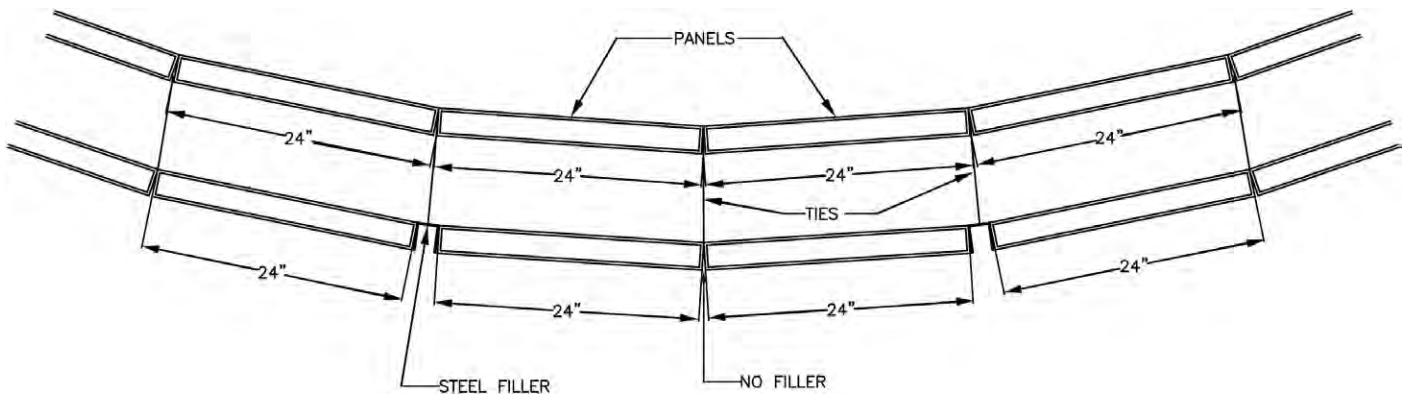

Typical Filler Configuration for Curved Gang

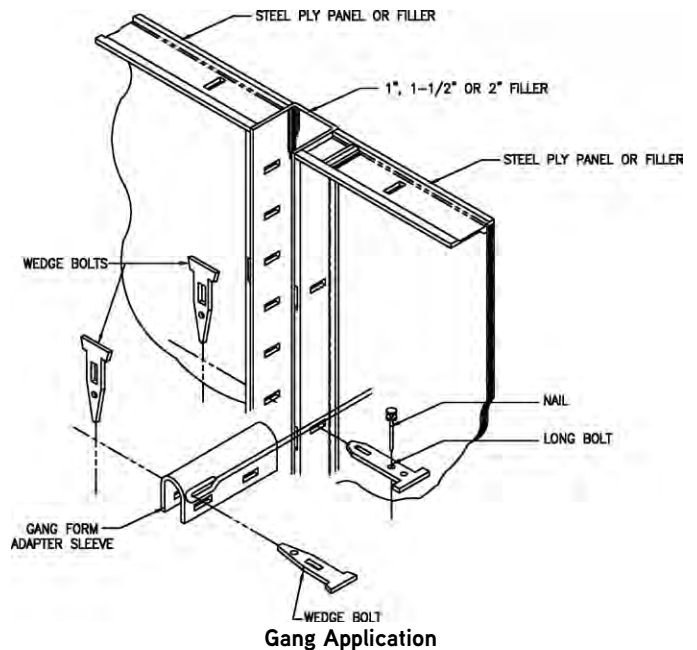
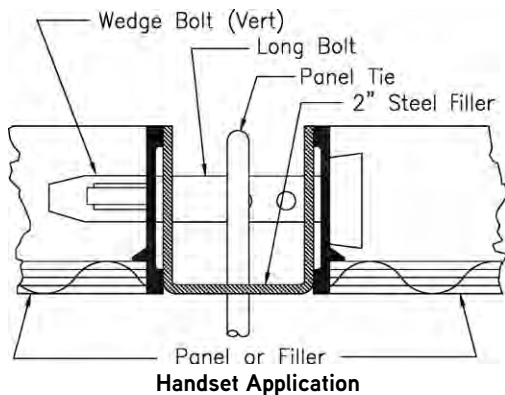

Walers are usually double 2x4 lumber, although 2x6 or 2x8 may be used. When the wall is curved, a lumber waler becomes an expensive item. This is particularly true with job-built lumber forms because the studs and walers must be fairly close together. Since the walers on Steel-Ply are for alignment only, very few are required. For example, a 16' high wall can be erected using only three horizontal aligning walers.

Horizontal Gang Alignment

One alternate way of providing straight or curved walers is to use 1 1/2" schedule 40 pipe or 1.90" Symons tubing. The pipe or tubing can be rolled to the desired radius and easily attached to Steel-Ply panels with the Pipe Aligner Hook. The pipe may be single pieces for the full length of the gang, double pipes, lapped pipes or spliced pipes. Which method is used is dictated by the size and radius of the gang. In any event, the only hardware needed is the Pipe Aligner Hook and Wedge Bolt.

Pipe aligners can be lapped and clamped at the same Wedge Bolt connection by utilizing two Pipe Aligner Hooks. The first Pipe Aligner Hook is attached at its normal dado slot position with the hook facing either up or down but in the direction to clamp the first pipe in place. The second Wedge Bolt then locks the connection at that point in the normal manner. The second Pipe Aligner Hook then clamps the other pipe by engaging on to the protruding end of the connecting Wedge Bolt. The hook is driven up snug against the Wedge Bolt and a double head nail is inserted to complete the double-hook connection. All Pipe Aligner Hooks clamping under lapping pipe will face downward.

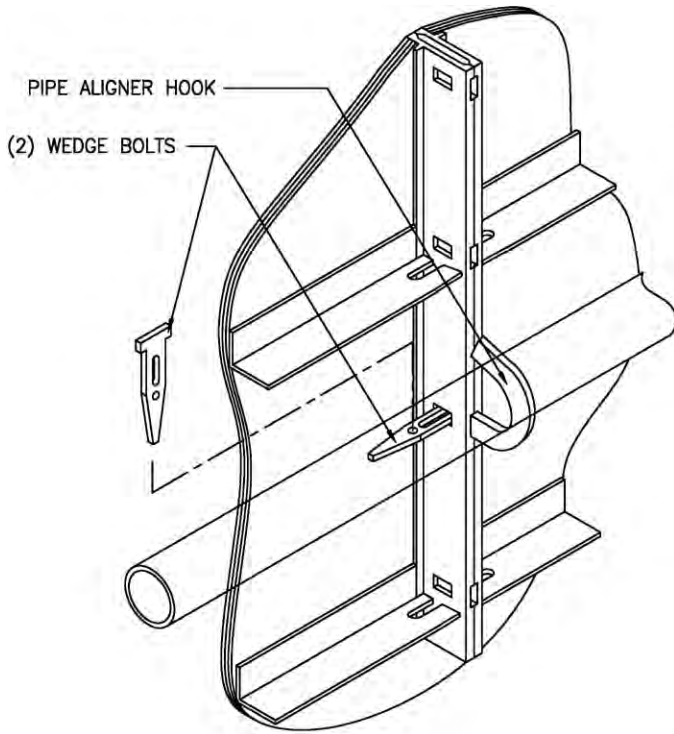

Pipe Aligner Hook Installation

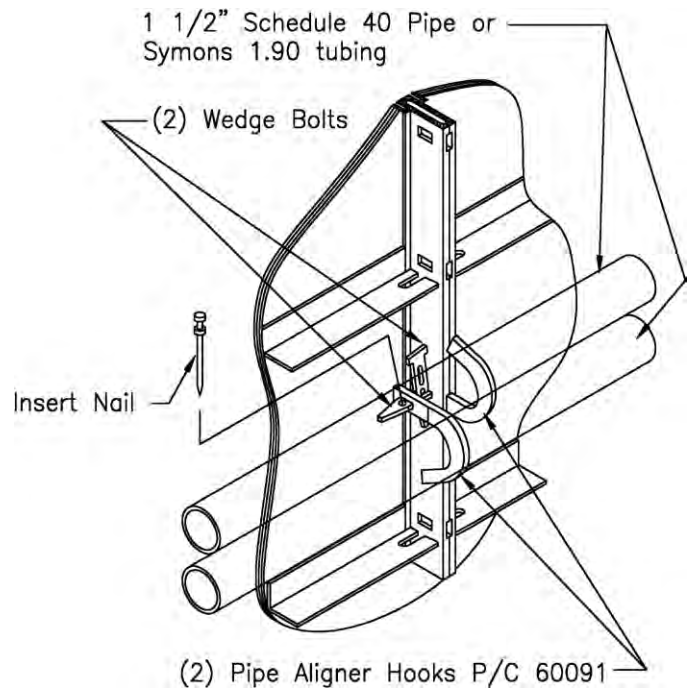

Installation of Two Pipe Aligner Hooks

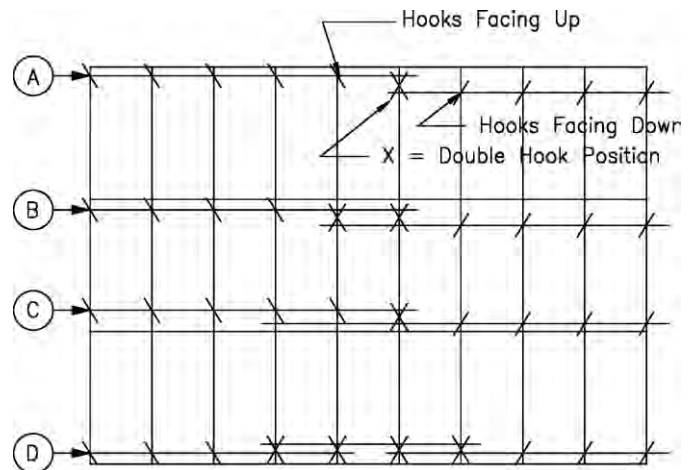

Pipe Aligner Hook Orientation with Lapped Pipe

3" Aligner Channel / 3" Channel Aligner Bracket

Panels may be aligned with straight or curved 3" steel channels. This is similar to the use of pipe as described previously. In this case, the channels are secured to the panels with the 3" Channel Aligner Bracket and the 8" Gang Waler Rod. The channel flanges may be up or down.

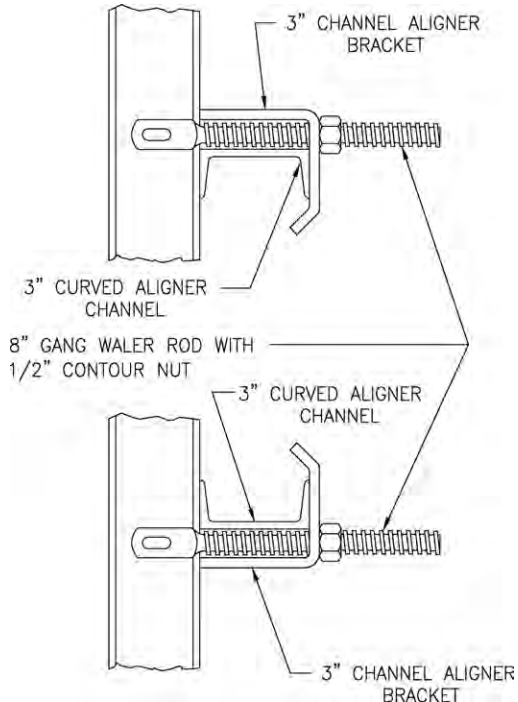

3" Aligner Channel Installation Methods

If channels are doubled or lapped, they are attached with the Gang Waler Plate and 8" Gang Waler Rod.

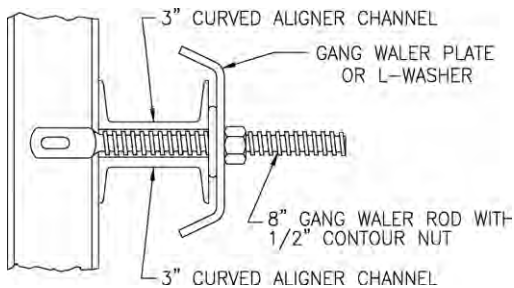

Installation of Lapped 3" Aligner Channels

Whenever a waler rod protrudes from the formwork, Symons advises the use of its Soft End Cap to prevent injury.

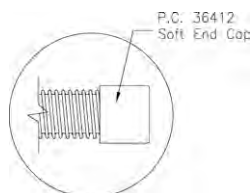

Soft End Cap Installation

Pipe or channels are most frequently used for alignment on curved walls. It should be kept in mind that pipes and channels can also be used on straight walls.

Vertical Strongbacks

Vertical double 2x4 or 2x6 strongbacks may be attached to horizontal pipe walers with the strongback U-Bolt and two Gang Waler Plates. If a steel strongback is preferred, Symons double 5" channel walers may be used. It is attached with the U-Bolt, but two plate washers are used instead of the Gang Waler Plates. The steel strongbacks and plate washers are rentable because they are component parts of another Symons system called Versiform®.

The forming of curved walls with Steel-Ply is much easier than using job-built forms because it is an "erector set" method and eliminates time-consuming job-built lumber construction.

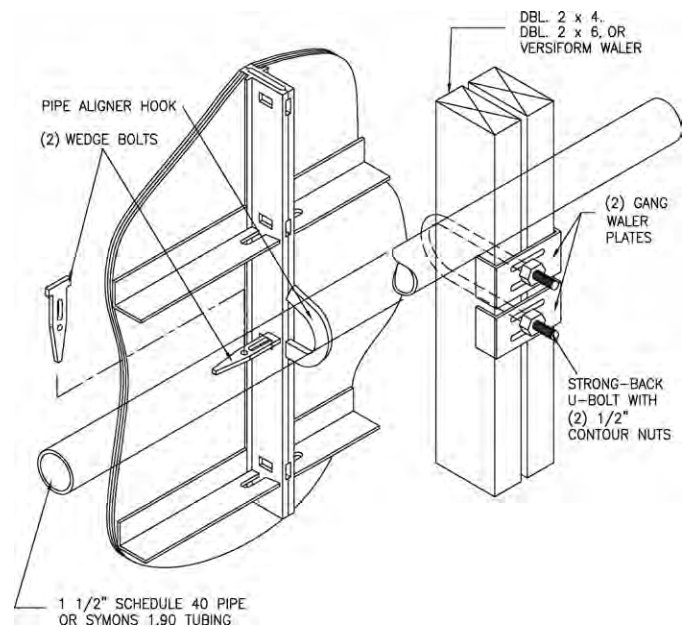

Strongback

Double Duty Lift Brackets

Two or more Gang Lift Brackets can be attached for the contractor's rigging. The Double Duty Lift Bracket fits over two adjoining panel side rails. A special Long Bolt, attached to the bracket, goes through the bracket and side rails and is secured with a Wedge Bolt. While this Double Duty Lift Bracket has a safe load capacity of 2,000lbs when the lift cable is vertical, its capacity reduces to 1,000lbs when the cable angle is at the minimum recommended angle of 45°.

CAUTION: Do not initiate breaking a gang form loose from a wall by lifting or tugging backward through the Double Duty Lift Bracket.

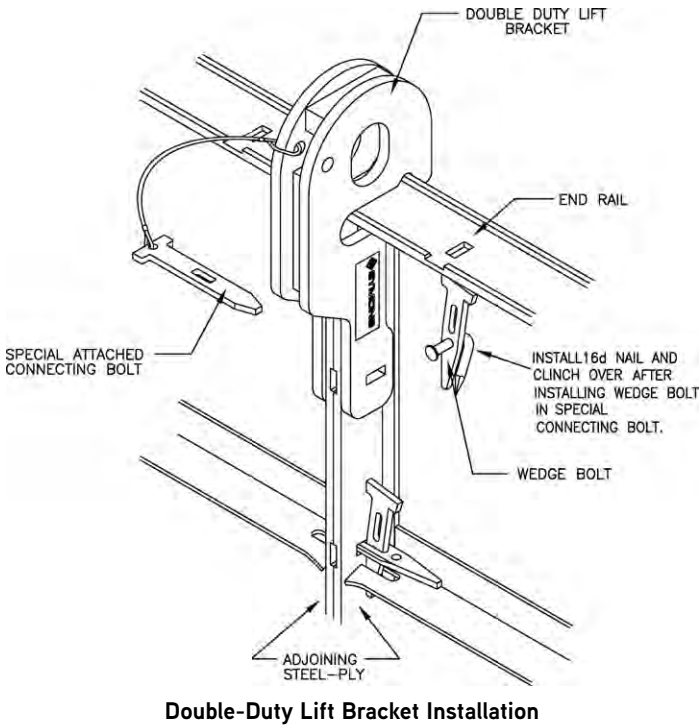

STEEL-PLY GANG FILLERS

The Steel-Ply Gang Filler is designed to increase productivity by reducing the number of ties required in conventional gang-forming. This 2" steel filler features two or three 1½" tie hole locations in the face to accept 15mm Taper Ties (1" to ¾"), She Bolts or Tie Rods with 15mm Tie Nuts to secure the tie.

The 2" Steel-Ply Gang Form Filler connects Steel-Ply panels together with a ¾" Flat Bolt and Nut (two or more connections per filler are required). The vertical spacing of the Flat Bolts should be from 6"-12" from the end of any panel or gang filler with a spacing no larger than 3ft apart. Staggering the Gang Fillers and the panel joints stiffens the gang and reduces the need for strongbacks. Less stiffening hardware results in an average gang weight of 8 pounds per square foot versus the 10-18 pounds per square foot for Horizontal Steel-Ply or Maxi-Water/Steel-Ply gangs.

Sizes

Gang Fillers come in 4ft, 6ft, 8ft and 10ft lengths. Fillers can be stacked for gangs taller than 10ft.

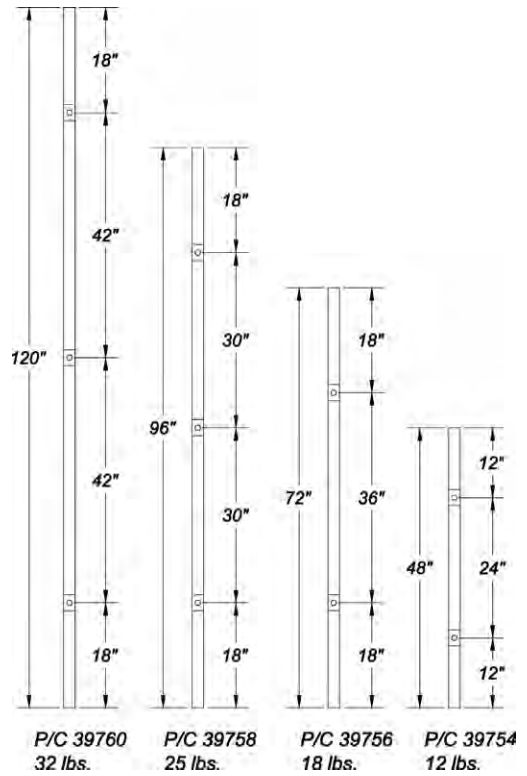

Gang Form Fillers

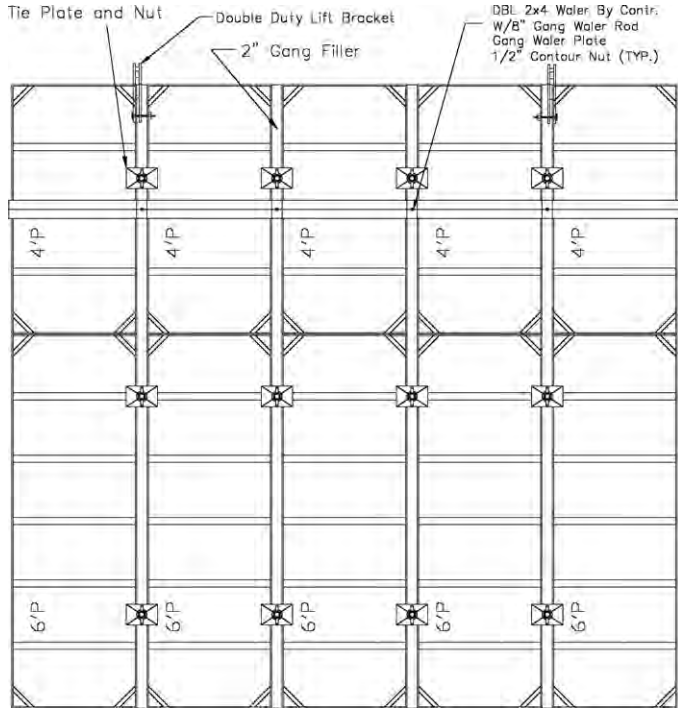

10' High Gang Filler Configuration

Waler

Double 2x4 walers are secured with the Gang Waler Plate, and 1/2" nut.

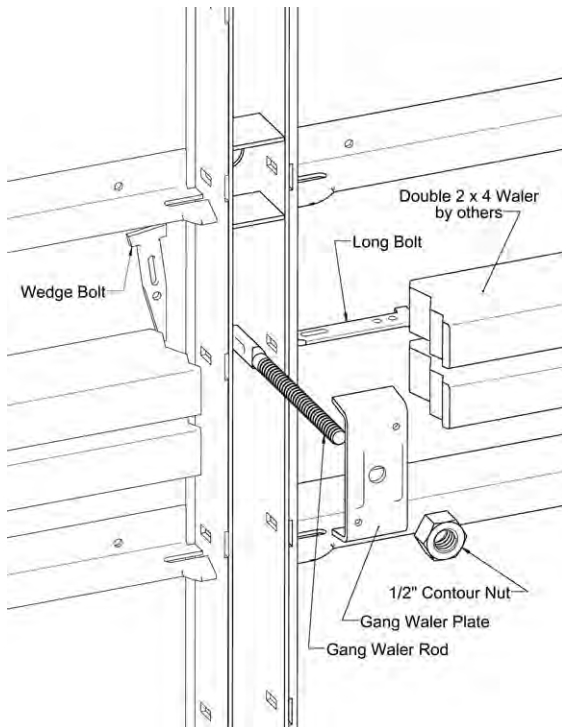

Gang Filler Double 2x4 Waler Attachment

NOTE: The 3/4" Coil Bolt will not fit through a Gang Waler Rod.

Turnbuckle

The Turnbuckle is attached with the 3/4" x 4" Flat Coil Bolt and Nut.

Double Duty Lift Bracket

The Double Duty Lift Bracket is attached with a 3/4" x 4" Flat Coil Bolt and Nut.

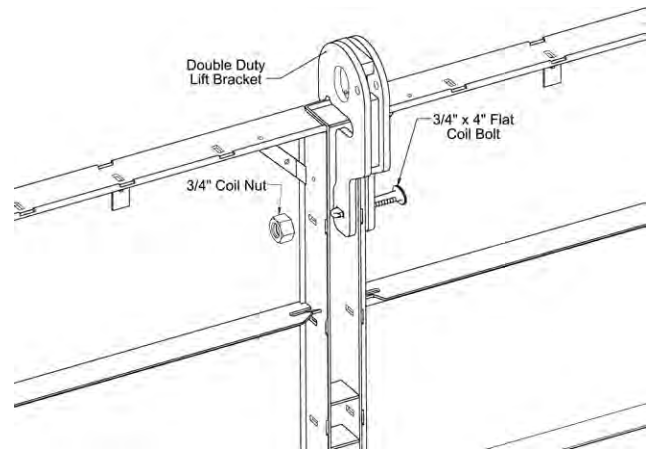

Gang Filler Double Duty Lift Bracket Attachment

Scaffold Bracket

The Scaffold Bracket is attached with the 3/4" x 4" Flat Coil Bolt and Nut.

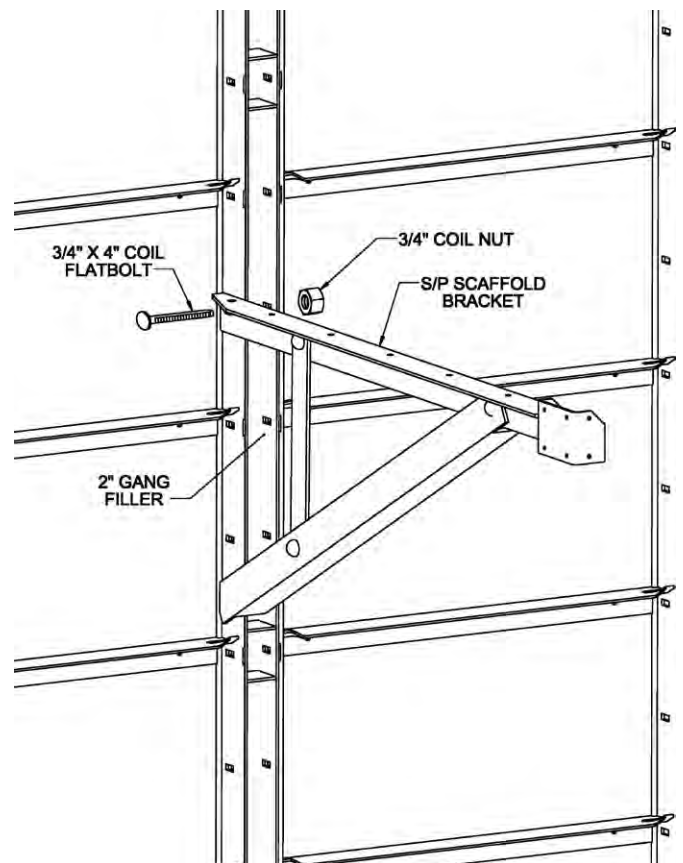

Gang Filler Scaffold Bracket Attachment

Ties

Ties are 15mm Taper Tiles (1" to 3/4") with a 4"x6" Tie Plate and Nut or 15mm She-Bolts with Inner Tie.

Ties Used with Gang Fillers	Wall Width
15mm x 27" Taper Tie	8" to 12"
15mm x 41" Taper Tie	11" to 15"
15mm x 49" Taper Tie	12" to 23"
15mm x 57" Taper Tie	27" to 31"
15mm x 65" Taper Tie	35" to 39"
15mm x 12" She-Bolt	6" min.

HORIZONTAL STEEL-PLY

Horizontal Steel-Ply gang forms utilize vertical Versiform® walers which permit the use of high capacity Taper or She-Bolt type ties. Horizontal Steel-Ply gangs are assembled using 6' and 3' panels in a brickwork pattern. Vertical Versiform walers can be attached directly to the Steel-Ply panels at 3' spacing. This results in a lighter weight and less expensive gang than one with Mini-Walers; however, pressure is restricted to 800 psf and gang lengths must be in increments of 3'. This is an excellent method of using ganged Steel-Ply where the length of the gang does not have to be altered.

If the horizontal Steel-Ply gangs are going to be attached to each other for a long straight wall, the bottom of the gang should be made with 12" fillers. All units above the 12" fillers may be panels. If the gangs will be attached to vertical Steel-Ply for corners or pilasters, the bottom of the gang should have 18" fillers above 6" fillers. These fillers will provide Wedge Bolt slots at the proper location for attachment of vertical Steel-Ply at the gang ends.

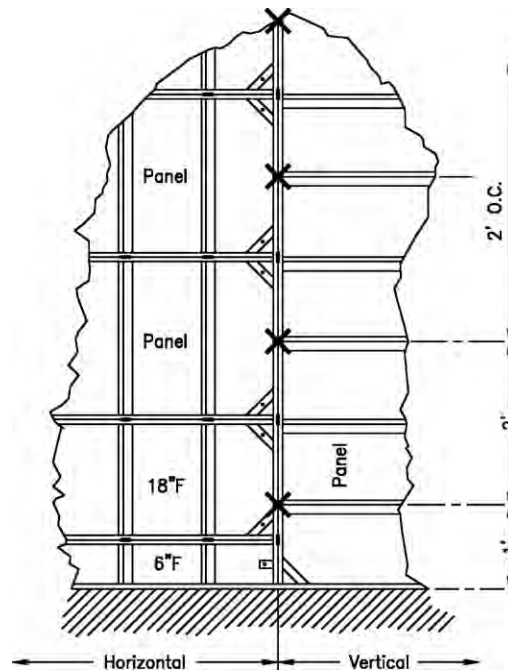

Attachment of Horizontal Gang to Vertical Gang

Horizontal Gang Assembly

← VERTICAL WALER SPACING →

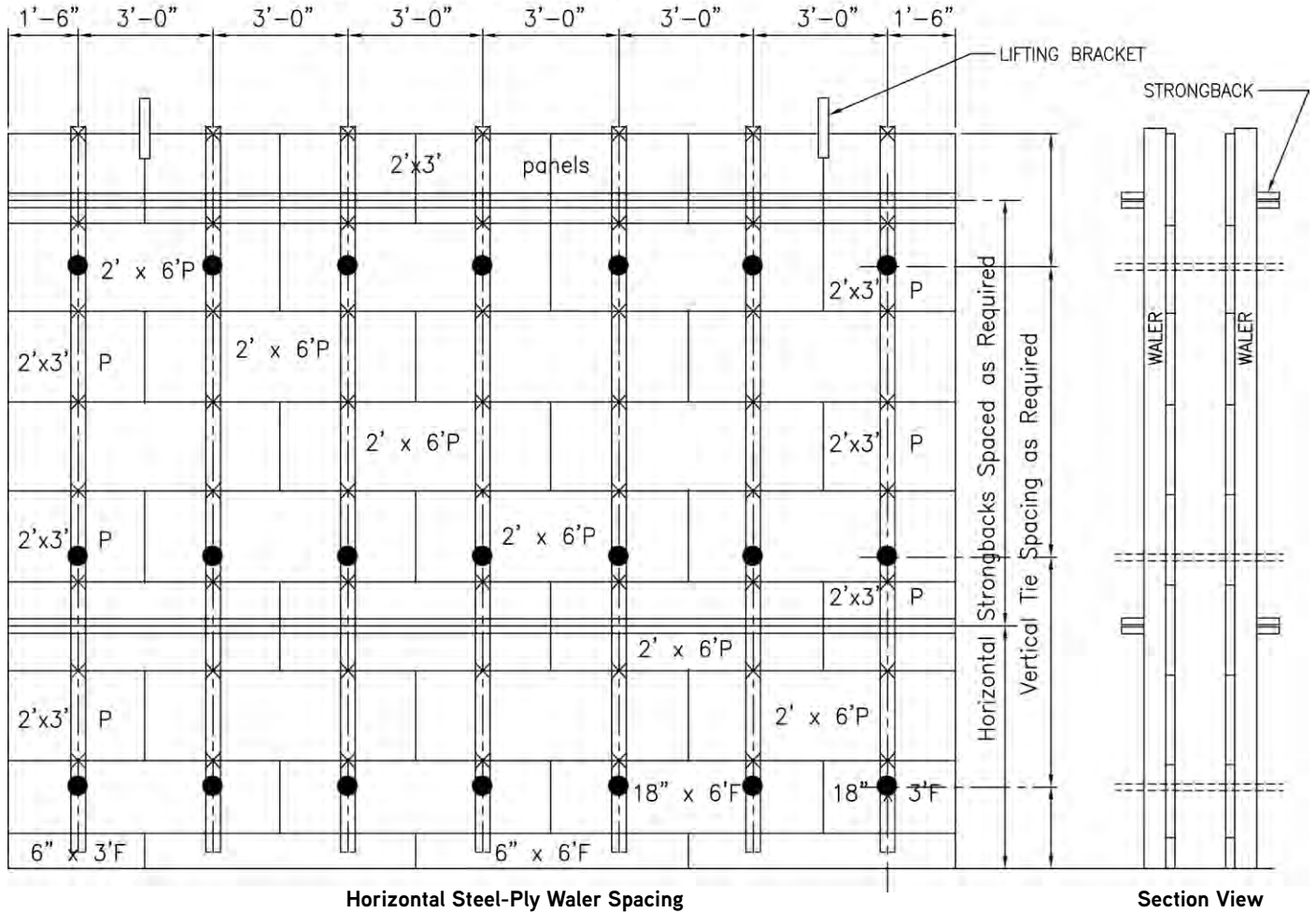

Horizontal Steel-Ply Water Spacing

Section View

To assemble the gang, lumber is placed on any reasonably flat surface and the forms are laid out with the plywood face down. Wedge Bolt connections are placed 6" in from the ends of the gangs and at 6" from the "T" intersections of the staggered panels. Steel walers will be attached at 1'-6" from gang ends and at 3'-0" spacing; therefore, at these points, 8" Gang Water Rods are connected to the side rails. The 5" double channel walers are placed over the rods and secured with Versiform® plate washers. In order to prevent slip of the waler, a panel waler connector should be used at one of the Gang Water Rods on each vertical waler. It should be realized that the nut on the Gang Water Rod should not be over tightened. Slip of the waler is prevented by the Panel Waler Connector; therefore, there is no need to try to develop a high friction connection between the waler and the Steel-Ply forms.

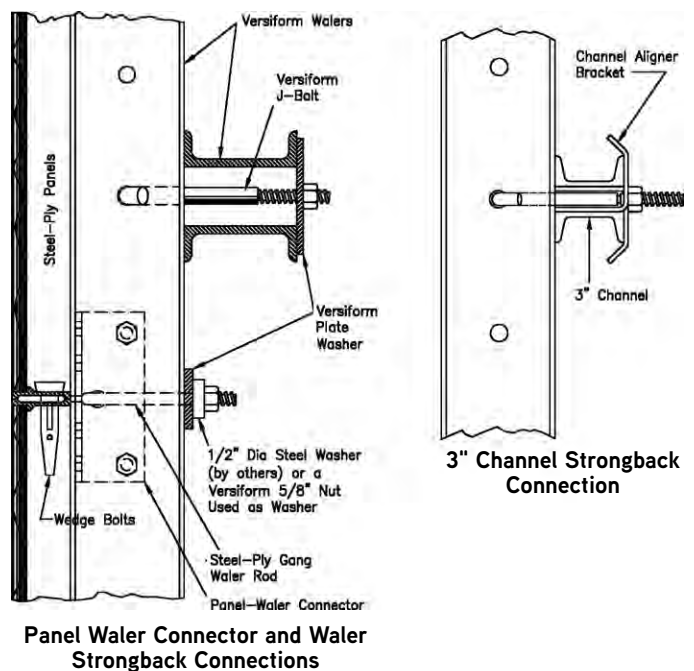

Panel Waler Connector and Waler Strongback Connections

3" Channel Strongback Connection

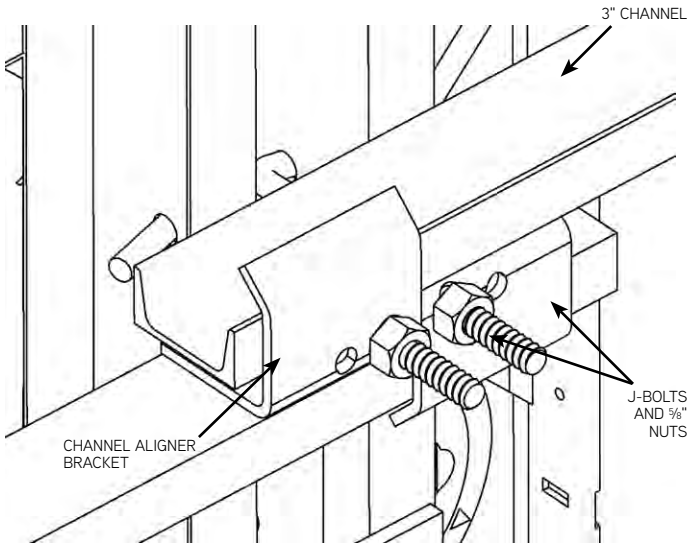

3" Channel Strongback Connection

Horizontal alignment and stiffness may be accomplished by using double 3" Aligner Channels or 5" Versiform walers if required. Aligner Channels are attached as shown and where necessary, Versiform walers may be attached with J-Bolts and Plate Washer.

CAUTION: When removing horizontal Steel-Ply or Maxi-Waler ganged forms, it is recommended that the She-Bolt or Taper Ties be left in the top row until the crane is attached to the gang form. When using Taper Ties, secure the opposite side gang to the concrete wall before removing the last two ties.

Walers

Standard 5" Versiform Walers are double 5" steel channels that are welded together through integral plate gussets which space them back-to-back 3" apart. Walers are positioned vertically, gathering form load from the Steel-Ply siderails, and transferring it to the wall ties. Walers also function to align and stiffen the gang form vertically.

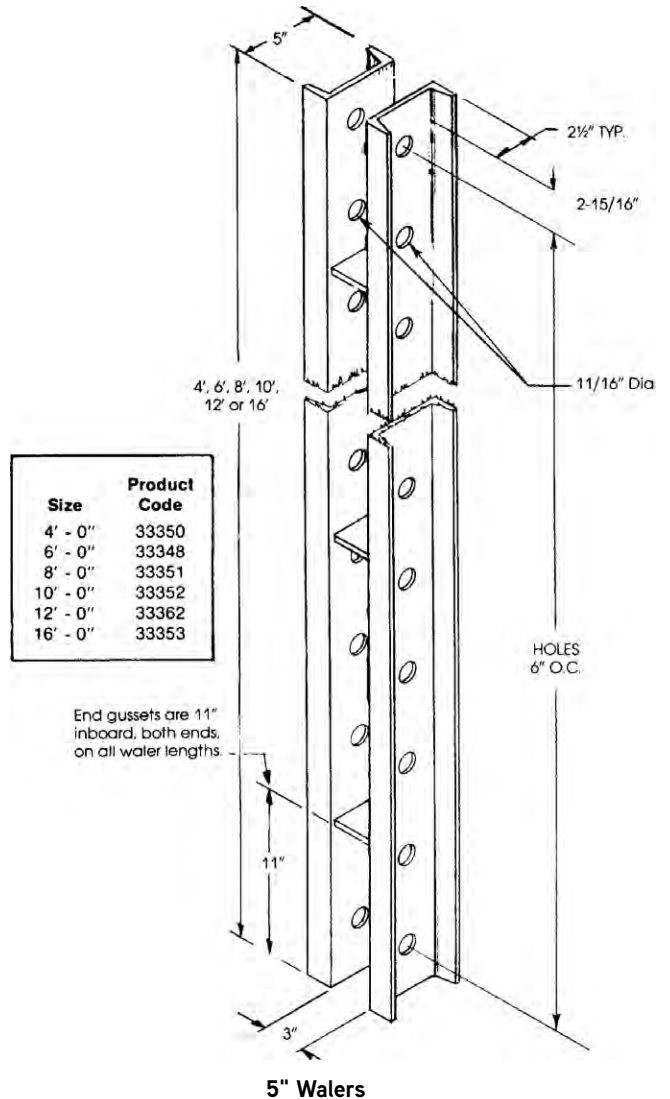

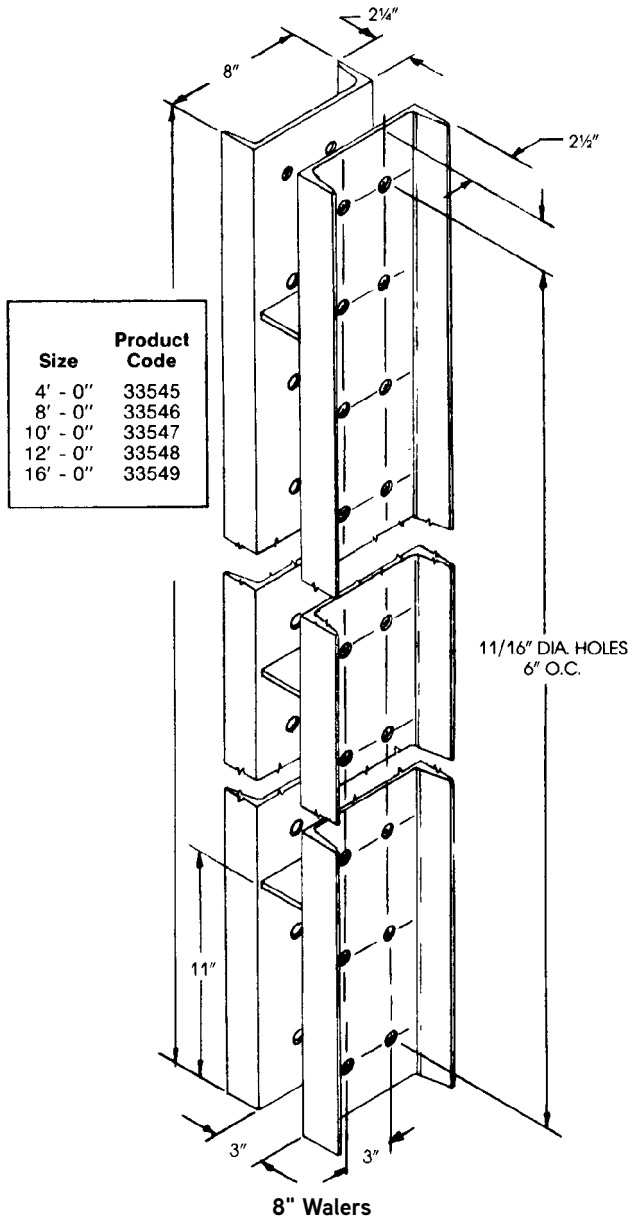

Standard 8" Versiform Walers are double 8" channels welded together through integral plate gussets which also space them 3" apart. The function of 8" walers is similar to 5" walers, but they add significantly to the weight and cost of the gang. They offer the capability of gathering more form load through increased vertical span between high capacity ties. 8" walers are available in several standard lengths.

Waler Splice Channels

Walers, longer than 16'-0", are created by installing the Waler Splice Channels at the adjoining ends of standard waler lengths. Twelve Fit-Up Bolts are required for a connection of 5" walers. Twenty-four Fit-Up Bolts are required for a connection of 8" walers. Care should be taken to align abutting walers prior to tightening the Fit-Up Bolts.

Waler Splice Sets can function as 1'-0" extensions to standard, even-foot waler lengths.

Splice channels have a lesser depth dimension than waler channels; therefore, approximate 1/4" thick spacers must be installed to provide bearing between the splice channels and the form.

CAUTION: Do not use Waler Lift Bracket on Splice Channels used as extensions.

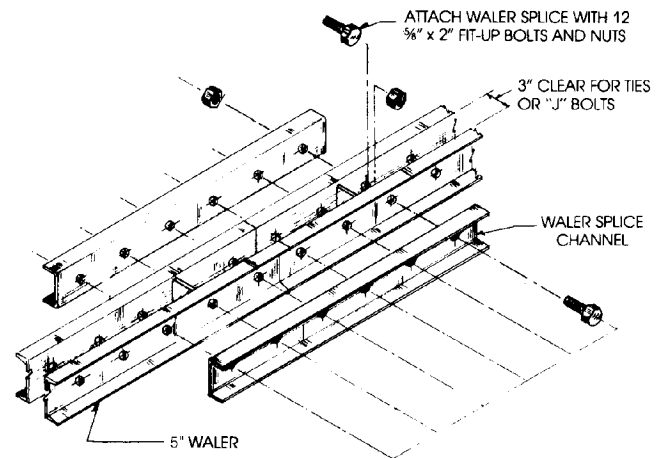

Waler Splice Angle Installation

ONE FOOT WALER EXTENSION NOTES

- UPPER WALL TIE LOAD SHOULD BEAR ON WALER CHANNEL FLANGES NOT SPLICE CHANNEL FLANGES
- ANY TYPE APPROPRIATE CAPACITY TIE WITH PROPER WALER BEARING HARDWARE CAN BE UTILIZED

“Y” Walls with 45° Walers and Splices

Horizontal Steel-Ply is used frequently for the forming of “Y” walls in sewage treatment plants. The 45° bends are formed with the Inside and Outside Bay Corners. The angle near the bottom of the wall is not usually 45° and, therefore, is formed with the Inside Hinged Corner. The vertical waler can be custom fabricated to fit the height and configuration of the wall, or standard Versiform® waler components including the correct combination of 45° waler and 45° splice sets can be utilized. Refer to horizontal Steel-Ply instructions which illustrate Versiform waler attachment to Steel-Ply panels.

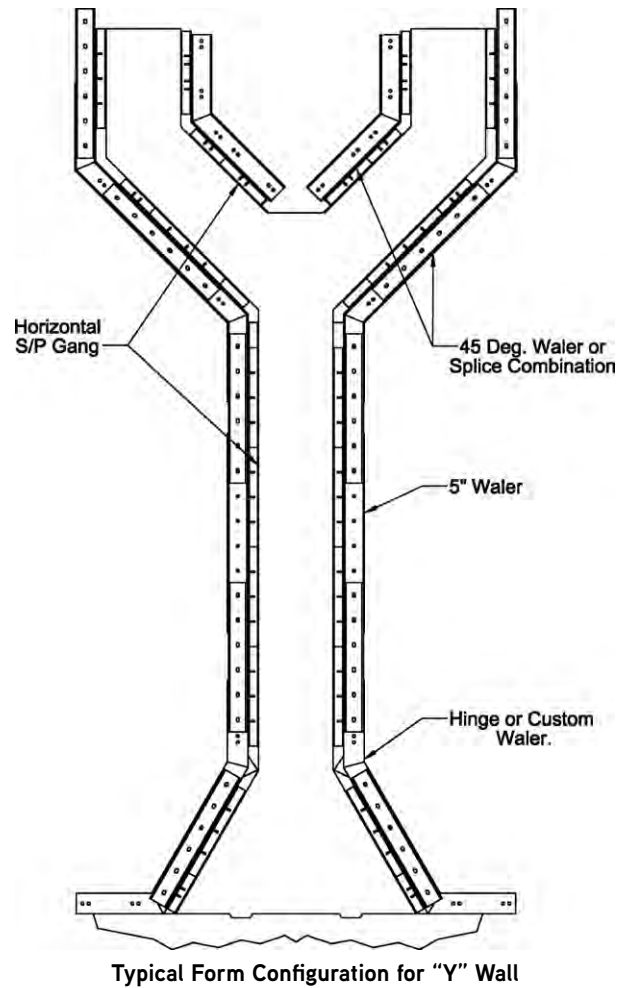
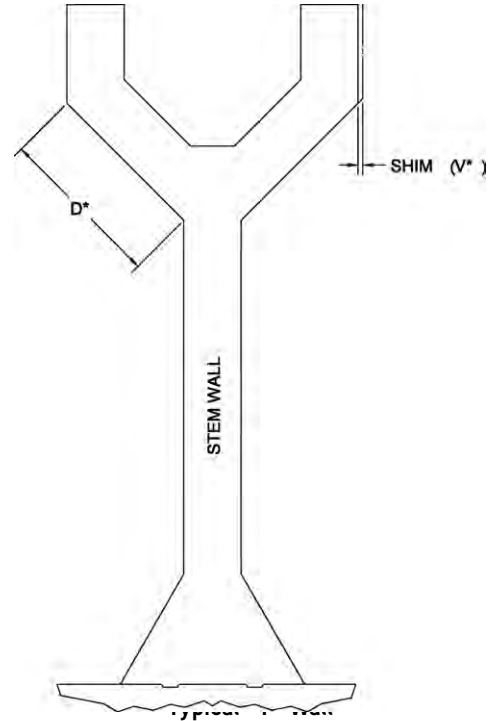
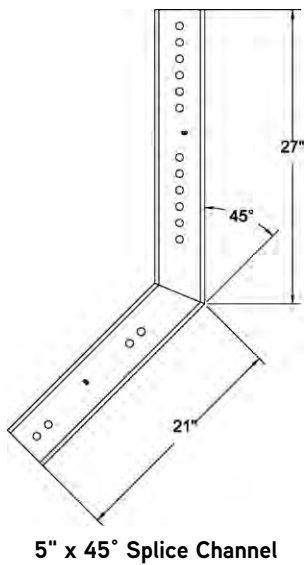
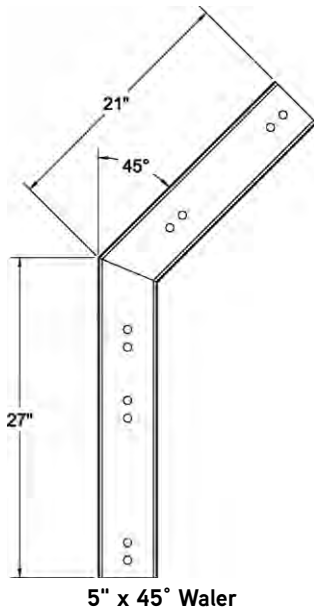

For 22" to 37" Diagonal Dimensions

The exploded parts sketch illustrates the 45° waler and 45° splice sets in one of four possible “turn-about-end” connection combinations to satisfy a 22" to 37" diagonal Y-Wall dimension. Either the waler or splice set can be the lower position component in the configuration depending on which offers dimensional advantage for connecting with the stem wall waler.

Component combination	"D" diagonal dimension (inches)
$\frac{45^\circ \text{ waler}}{21" \text{ end}} + \frac{45^\circ \text{ splice}}{21" \text{ end}}$	22 - 23½ - 25
$\frac{45^\circ \text{ waler}}{21" \text{ end}} + \frac{45^\circ \text{ splice}}{27" \text{ end}}$	25 - 26½ - 28 - 29½ - 31
$\frac{45^\circ \text{ waler}}{27" \text{ end}} + \frac{45^\circ \text{ splice}}{21" \text{ end}}$	28 - 29½ - 31
$\frac{45^\circ \text{ waler}}{27" \text{ end}} + \frac{45^\circ \text{ splice}}{27" \text{ end}}$	28 - 29¼ - 31 - 32¼ - 34 - 35¼ - 37

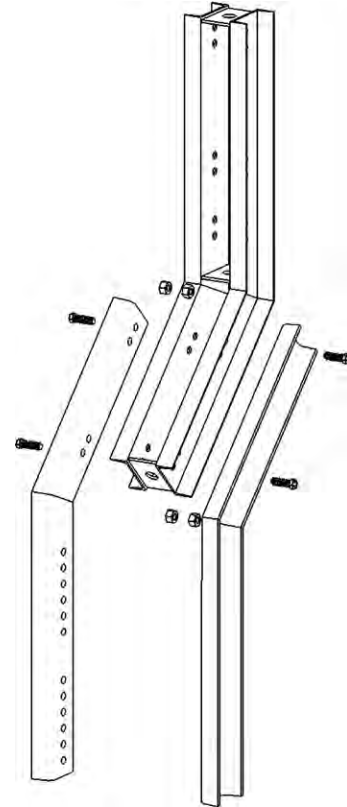

45° Waler and 45° Splice Set Assembly

For 40" to 55" Diagonal Dimensions

The exploded parts sketch illustrates two 45° walers and straight 5" splice channels positioned in one of three possible “turn-about-end” combinations to yield diagonal dimensions of 40" to 55".

Component combination	"D" diagonal dimension (inches)
$\frac{45^\circ \text{ waler}}{21" \text{ end}} + \frac{\text{Straight Splice}}{5" \text{ channel}} + \frac{45^\circ \text{ waler}}{21" \text{ end}}$	40 - 41½ - 43
$\frac{45^\circ \text{ waler}}{27" \text{ end}} + \frac{\text{Straight Splice}}{5" \text{ channel}} + \frac{45^\circ \text{ waler}}{21" \text{ end}}$	46 - 47½ - 49
$\frac{45^\circ \text{ waler}}{27" \text{ end}} + \frac{\text{Straight Splice}}{5" \text{ channel}} + \frac{45^\circ \text{ waler}}{27" \text{ end}}$	52 - 53½ - 55

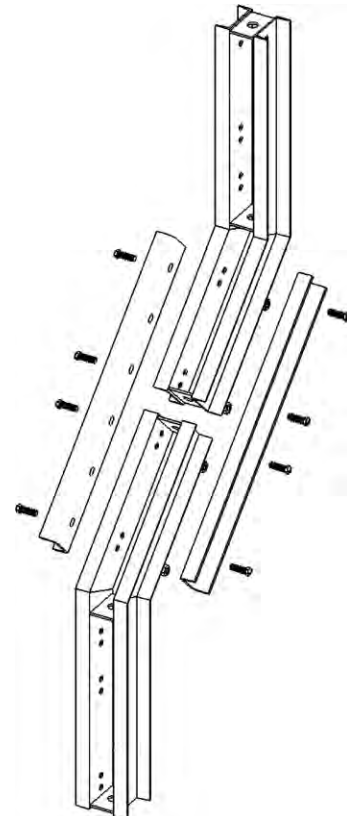

45° Walers and 5" Splice Channel Assembly

For 52" to 67" Diagonal Dimensions

The exploded parts sketch illustrates two 45° splice sets and a 4' waler positioned in one of three possible "turn-about-end" combinations to yield a diagonal dimension of 52" to 67".

Component combination			"D" diagonal dimension (inches)
45° splice 21" end	+ 4 ft. waler	45° splice 21" end	52 - 53½ - 55
45° splice 27" end	+ 4 ft. waler	45° splice 21" end	52 - 53½ - 55 - 56½ - 58 - 59½ - 61
45° splice 27" end	+ 4 ft. waler	45° splice 27" end	52 - 53½ - 55 - 56½ - 58 - 59½ - 61 62½ - 64 - 65½ - 67

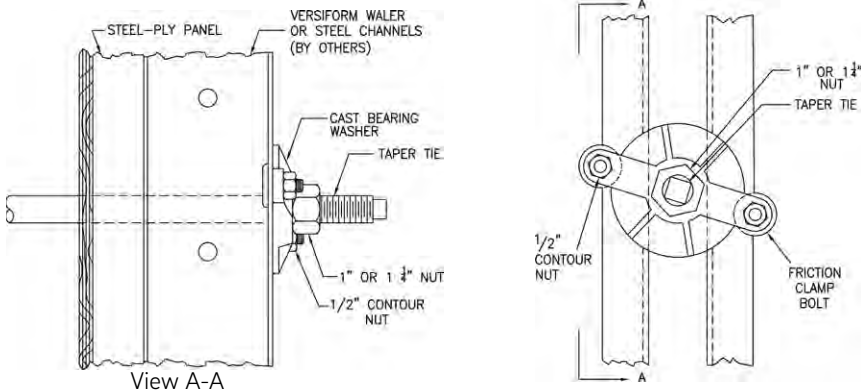
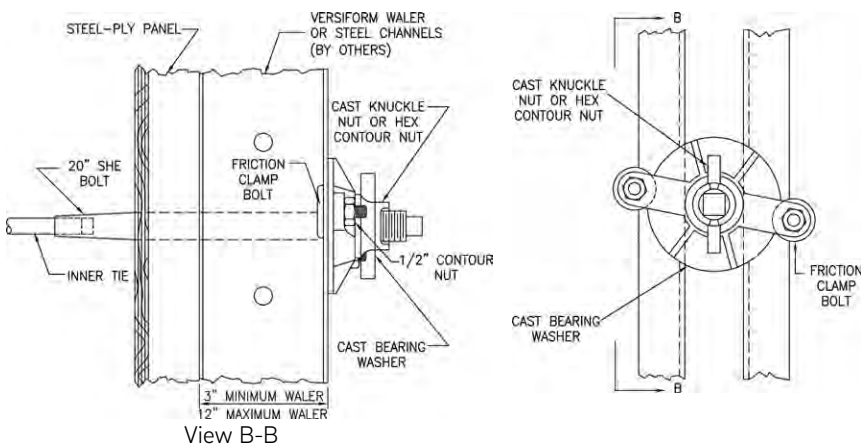
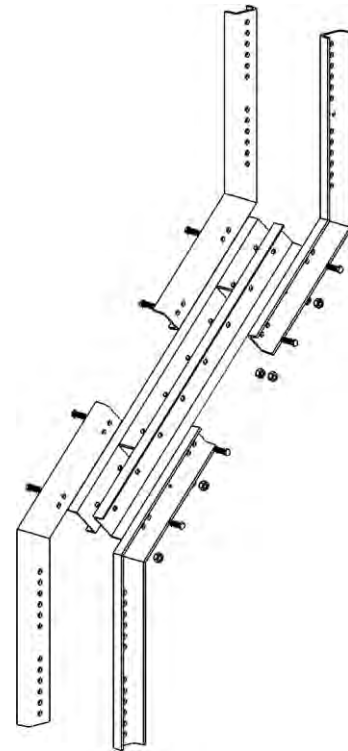
Cast Bearing Washer and Taper Tie Detail

Cast Bearing Washer and She-Bolt Detail

45° Splice Sets and 4' Waler Assembly
NOTES:

1. All splice connections require two pairs of Fit-Up Bolts spaced a minimum of 12" apart.
2. Variant dimension (V) will most often be less than 1" and can always be accumulated at the upper Y-Leg as noted. (Provide necessary shims between form and waler.)
3. Dead weight of all eccentrically placed concrete must be compensated for by adequately designed cross-yokes and shore-type bracing.

NOTE: For Taper Tie and She-Bolt, use Versiform® Spreader Clip (see Spreader Clip info in following Maxi-Waler Wall Gang section) or temporary job-built spreader.

MAXI-WALER WALL GANGS

Assembly

The Maxi-Waler system uses double 3" steel channels attached to Steel-Ply panels at 2' on center vertically. The channels serve both as load gathering members and as alignment for the gang. "L" washers and 8" Gang Waler Rods are used at every form joint to attach the two 3" channels (legs facing each other) to the forms. J-Strongback Waler Rods and plate washers are used to connect the Versiform double channel waler to the 3" channels at 4' spacing horizontally. The waler is attached to every third or fourth double 3" channel.

CAUTION: A Panel Waler Connector and Clip Angle must be used at one location per waler to prevent the waler from slipping.

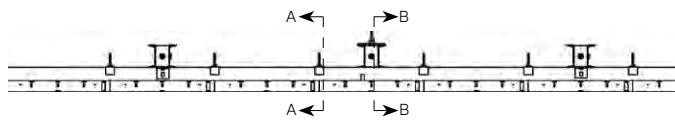

Typical Max-Waler Attachment

CAUTION: Two (2) L-Washers should be installed with flanges on top of, AND NEAR EACH END of the 3" channels. The others should have flanges below.

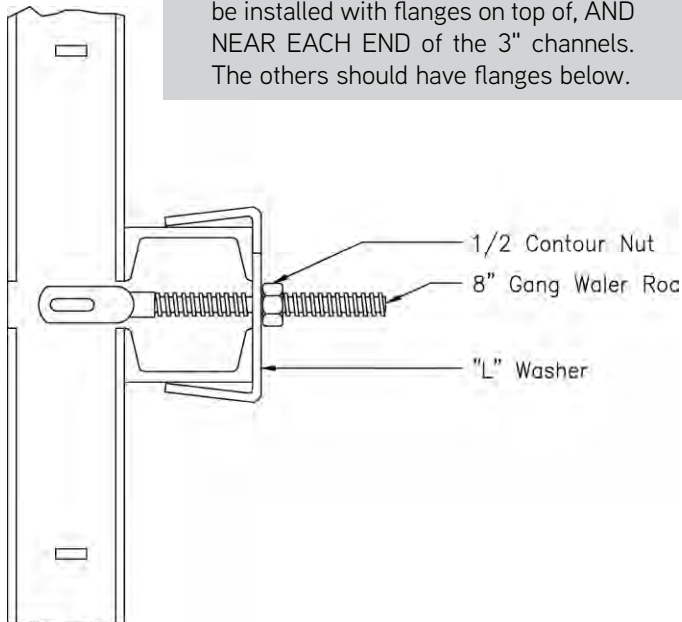

View A-A

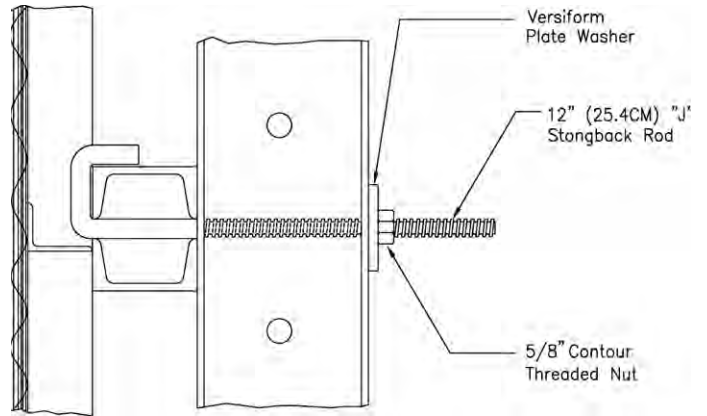

View B-B

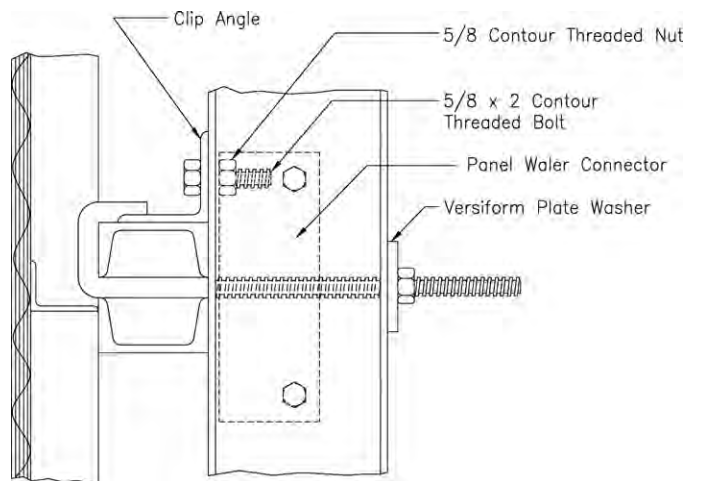

View B-B
(One per Waler)

Spreader Clip

The Spreader Clip can be used with Taper Ties or She-Bolts. It is a U-shaped plate that fits over the Cast Bearing Washer and hex nut, thereby preventing any inward movement of the forms. A tie with Spreader Clips near the bottom of the forms and one tie with Spreader Clips near the top of the form will maintain the desired wall thickness.

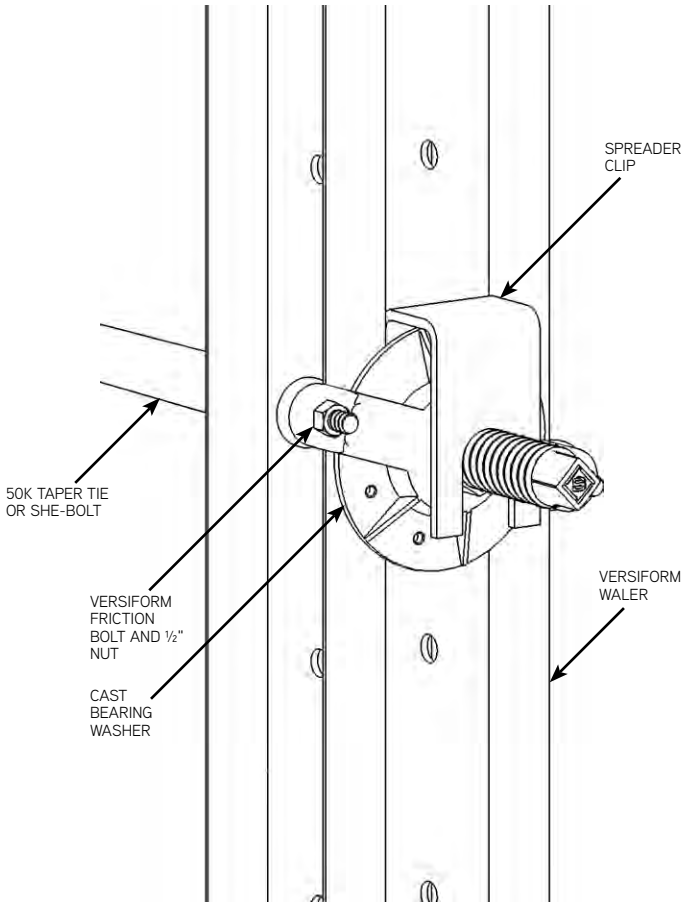

Typical Installation with Spreader Clip

Adjustable Top Tie

If Symons Versiform® walers are used vertically as strongbacks, and the top tie can go over the top of the forms, the Adjustable Top Tie can be used instead of a Taper Tie or She-Bolt tie. This unit acts as both a tie and a spreader. By merely loosening the outer nuts one turn, the unit can be lifted out of the open slotted brackets attached to the Versiform channel strongbacks. When installing, the unit is dropped into the slotted brackets, and the outer nuts are tightened.

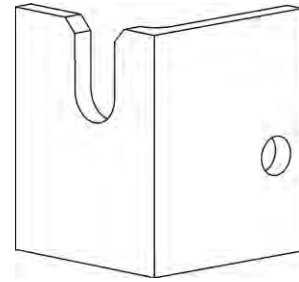

Top Tie Bracket

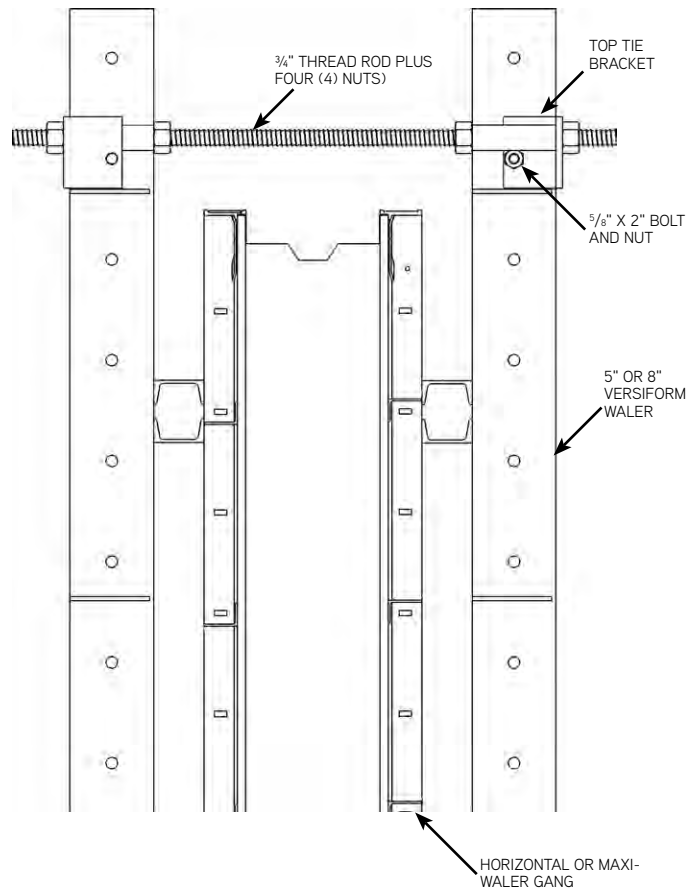

Typical Adjustable Top Tie Installation

Waler Lift Brackets

Use of Waler Lift Bracket with Waler Connector and 2'-0" Steel-Ply Siderail Crossbar on Maxi-Waler gangs.

- I. One Waler Connector and 2'-0" Steel-Ply Siderail Crossbar is required per lifting waler.

CAUTION: Only vertical load can be imposed at lift hole of Waler Lift Bracket. A lifting beam with vertical "drop lines" to Waler Lift Brackets must be used.

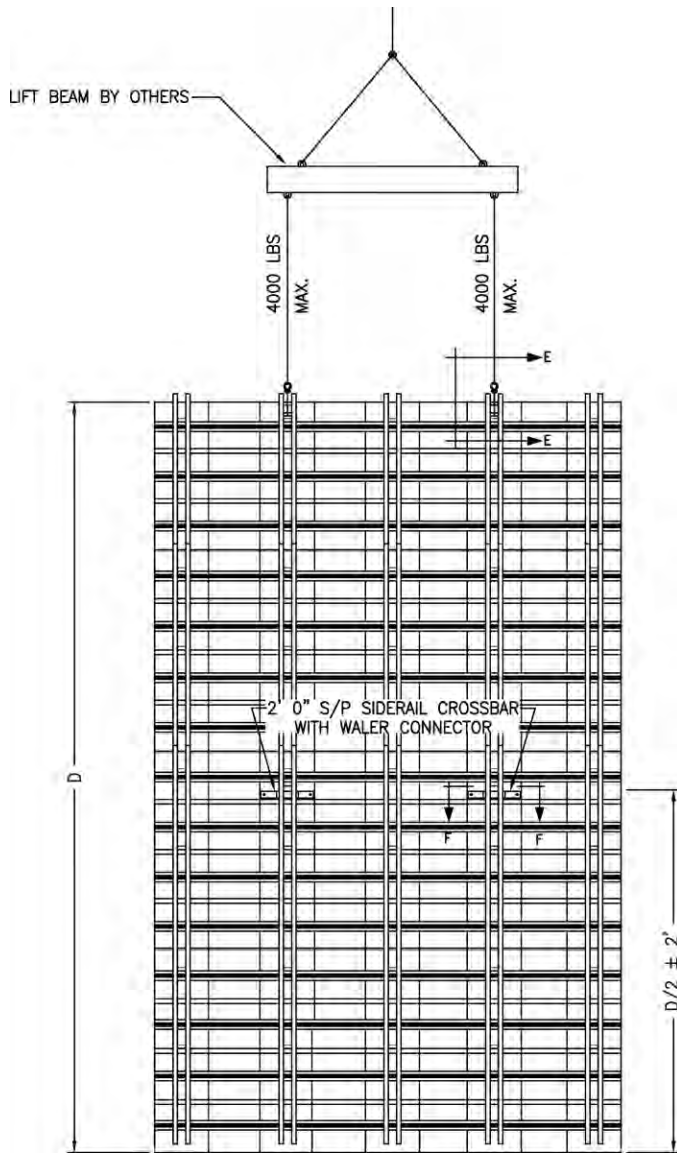

Typical Gang Configuration with Waler Lift Bracket

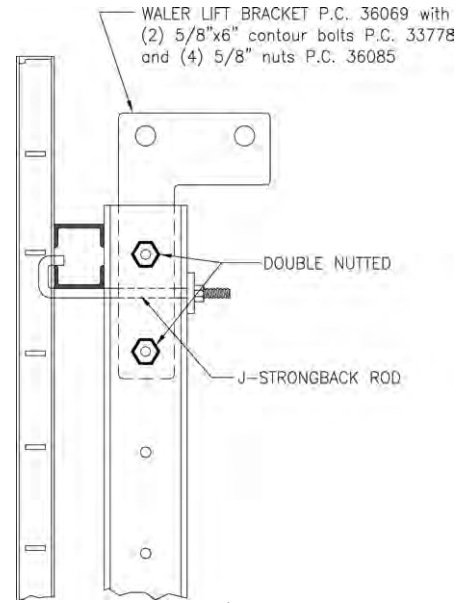

**View E-E
Waler Lift Bracket Installation with
Bracket Facing Away From Forms**

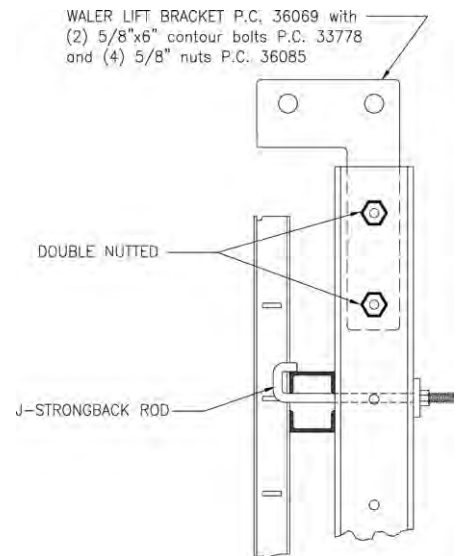

**View E-E
Waler Lift Bracket Installation with
Bracket Facing Forms**

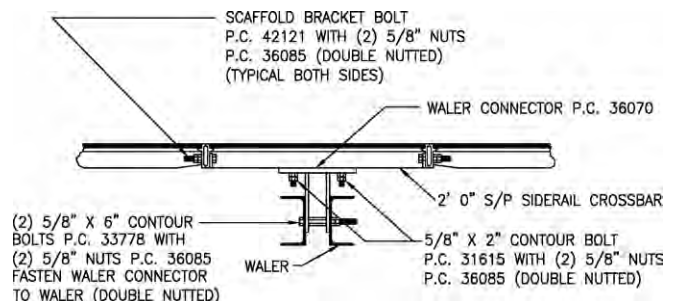

**View F-F
Siderail Crossbar Installation**

II. The Steel-Ply Siderail Crossbar can only be attached to 2'-0" wide Steel-Ply panels. The Siderail Crossbar is located approximately at mid-depth of the gang. Scaffold Bracket Bolts fasten the Siderail Crossbar to the Steel-Ply side rail. Do not use Long Bolts or Wedge Bolts. "Double nut" the Scaffold Bracket Bolt.

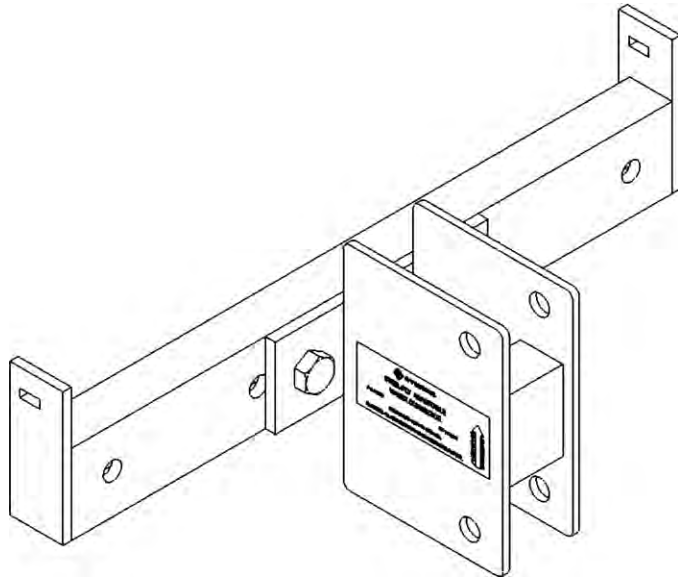

Panel Waler Connector Installed on 2'-0" Steel-Ply Siderail Crossbar

The Panel Waler Connector can be attached at 5 different locations on the side rail crossbar. The chart below gives the safe load capacities in those locations.

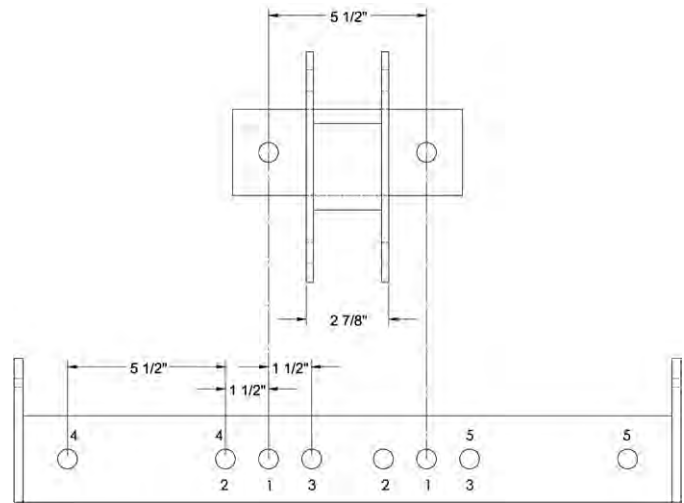

Waler Connector and 2'-0" Steel-Ply Siderail Crossbar

Bolt positions	Safe load capacity
1-1, 2-2, 3-3	4,000 lbs.
4-4, 5-5	3,600 lbs.

(At 5:1 Safety Factor)

- III. 1½" is the maximum size steel filler which can be used at location to enable Scaffold Bracket Bolt to be "double nutted".
- IV. When the Lifting Waler is fastened to the Steel-Ply gang using the Panel Waler Connector and 2'-0" Steel-Ply Siderail Crossbar, the holes in the waler are level with the dado slots in the Steel-Ply. This means that the Lifting Waler will project above the top of the gang a minimum of 3" or end 9" below the top of the gang. The bottom of the waler is always 3" above the bottom of the Steel-Ply gang.
- V. "Double nut" the 5/8" x 6" contour bolts fastening Waler Lift Bracket and Waler Connector to Versiform® waler.
- VI. "Double nut" the 5/8" x 2 contour bolts fastening the Panel Waler Connector to the 2'-0" Steel-Ply Siderail Crossbar.
- VII. Panel Waler Connectors are not needed on Lifting Waler because of the Side Rail Crossbar and waler connection, but are still required on non-lifting walers.
- VIII. Only vertical loads can be imposed at lift hole of Waler Lift Brackets. A lifting beam (by others) with vertical "drop lines" to Waler Lift Brackets must be used.
- IX. Use two "L" washers to secure Maxi-Waler to Steel-Ply panel on each side of lifting waler. Connect Lifting Walers to every Maxi-Waler with J-Strongback Rods.

GANGED CORE FORMS

Double Hinged Fillers

Four gangs can be connected at the corners with Inside Corners and Double Hinged Fillers, and the entire unit can remain intact during setting, pouring and stripping. The Double Hinged Filler has hinge points which permit inward movement of the four sides upon retraction of the turnbuckle connection to the sides at the corners. After positioning the core wall gang for the next pour, the turnbuckles are expanded, and the unit takes its original rectangular shape.

NOTES ON 27" RATCHET TURNBUCKLE:

- Initiates release of corewall gang
- Retracts the Double Hinged Filler into its full contracted position
- Coreform gang assumes foreshortened rigid box dimensions
- Repositions Double Hinged Filler back to 180°

Because the box-like gang form contracts and expands, it needs a surface on which to slide. Timbers are placed on Adjustable Shear Wall Brackets and are secured to the bracket by placing Wedge Bolts through the two holes in the bracket plate with the nose upward. The Wedge Bolt is nailed to the timber. After each gang wall face is shifted inward, the coreform is lifted and placed on temporary timbers across the top of the stripped corewall. The Adjustable Shear Wall Brackets and their timbers are moved up for the next pour. The gang is reset and expanded for the following pour.

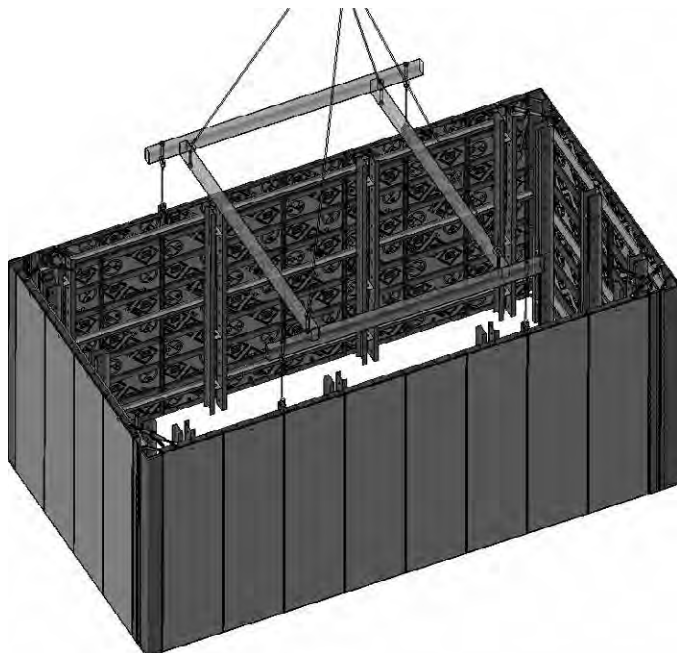

Typical Core Wall Gang
with Rectangular Lifting Frame

Lifting Core Forms

Although the corewall gang may be lifted by a lifting beam with angled slings to the Gang Lift Brackets, a rectangular shaped lifting frame will give the fastest and most efficient method of handling the coreform. Slings between the Gang Lift Brackets and frame will be near vertical and little, if any, lateral force will be placed on the upper part of the gang form.

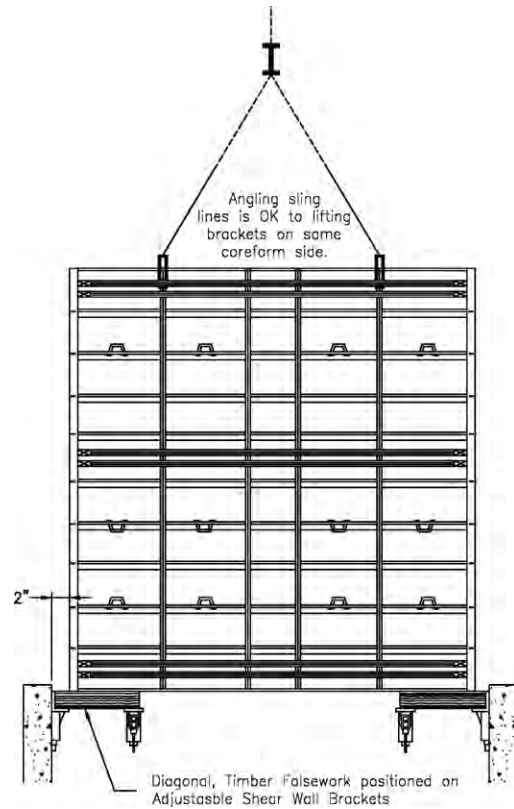

Longitudinal Core Section Showing Lift Lines

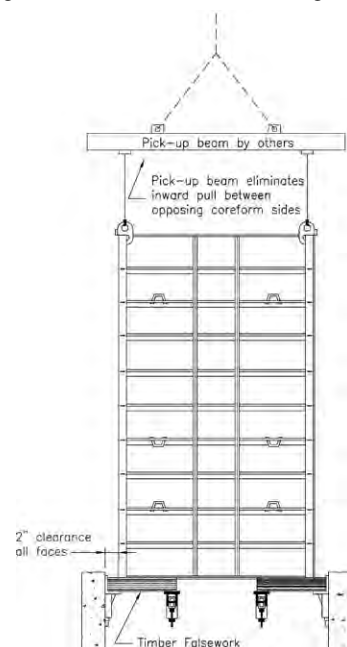

Cross Core Section Showing Lift Lines

Double Hinged Filler
Square Corner Corewall Gang Forms

Application notes:

1. Double Hinged Fillers must position symmetrically to the same side of each standard Inside Corner.
2. The 2" face increment rigid side rail must connect to the inside corner, because the foreshortening function of the 4" face increment must occur through its hinged side rail connection to adjoining wall face forms.
3. Do not install 1", 1½" or 2" fillers at either side of the Double Hinged Filler or Inside Corner.
4. All connecting Wedge Bolts must be installed so that they point away from the Double Hinged Filler. If they are inadvertently installed pointing into the Double Hinged Filler, their tapered ends would protrude 2¾", and obstruct the foreshortening fold function.
5. Double Hinged Filler side rails do not contain tie dados for use of wire gang form ties.
6. The 27" ratchet turnbuckles install at the Wedge Bolt slots 18" each way from the coreform corners.
7. The vertical center line of tie holes and vertical waler should position a minimum of 18½" away from the coreform corner so as not to conflict with turnbuckles.

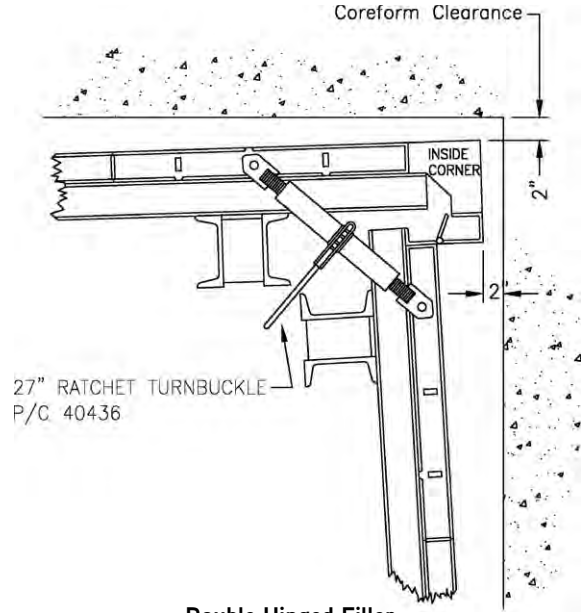

Double Hinged Filler
(in fold position)

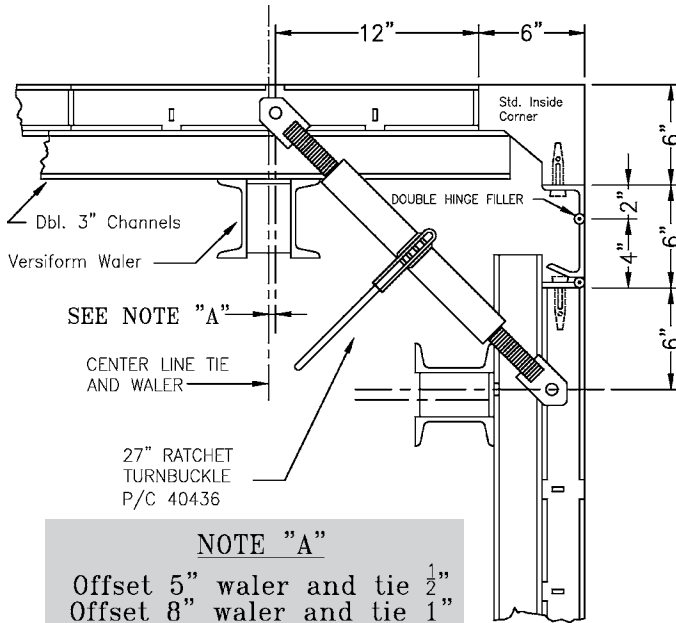

NOTE "A"

Offset 5" waler and tie ½"
Offset 8" waler and tie 1"

Double Hinged Filler
(in pour position)

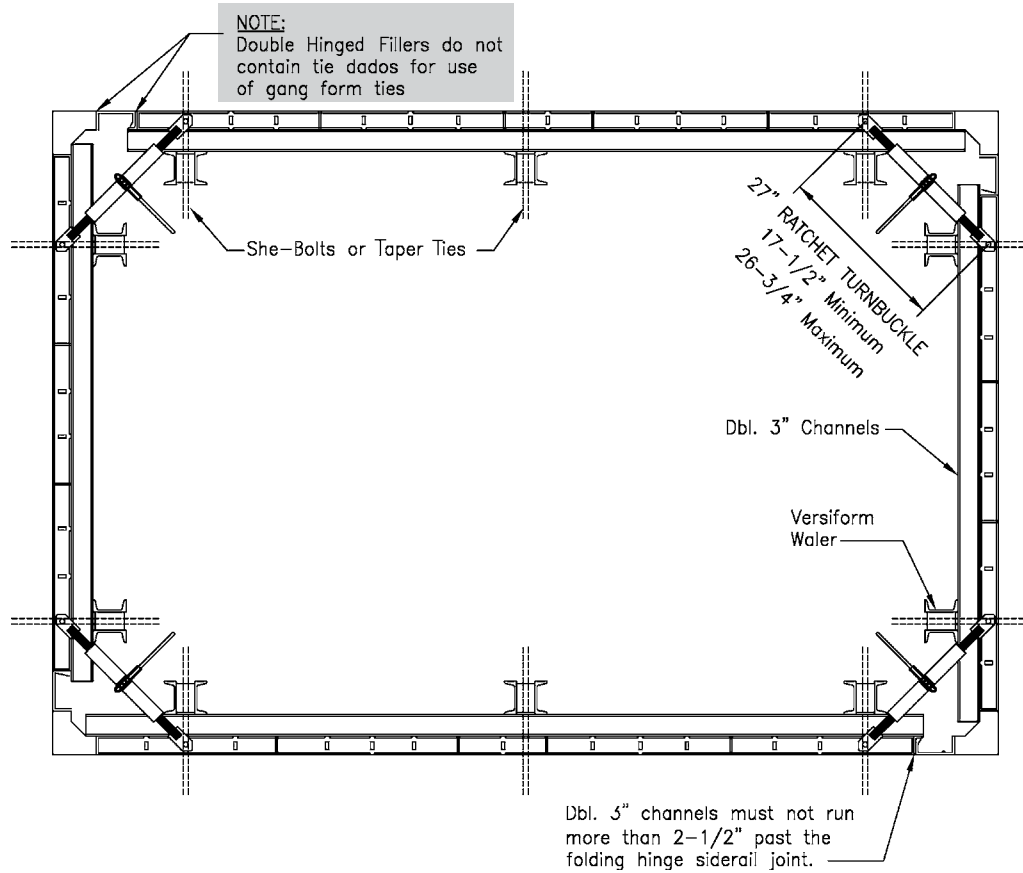

Double Hinged Fillers (in pour position)

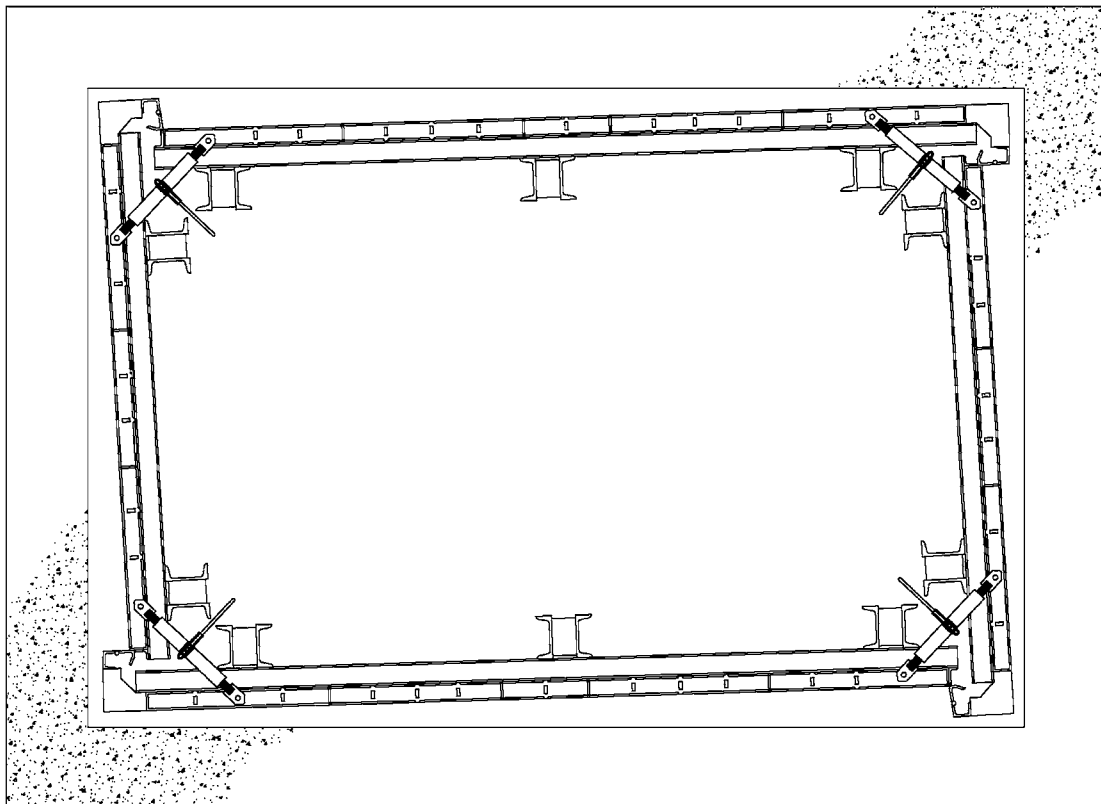

Double Hinged Fillers (in fold position)

Double Hinged Filler

Chamfer Corner Corewall Gang Forms

In order to form certain size chamfers to near exact dimensions, a 1" or 1½" all-steel filler plus a larger filler are required. For example: a 1" filler plus a 12" filler installed between two Double Hinged Fillers will form an exact 12" x 12" chamfer, but if a slight dimensional variance would be acceptable, the need to use a 1" filler could be eliminated and a single 14" filler could be utilized forming a 12½" x 12½" chamfer.

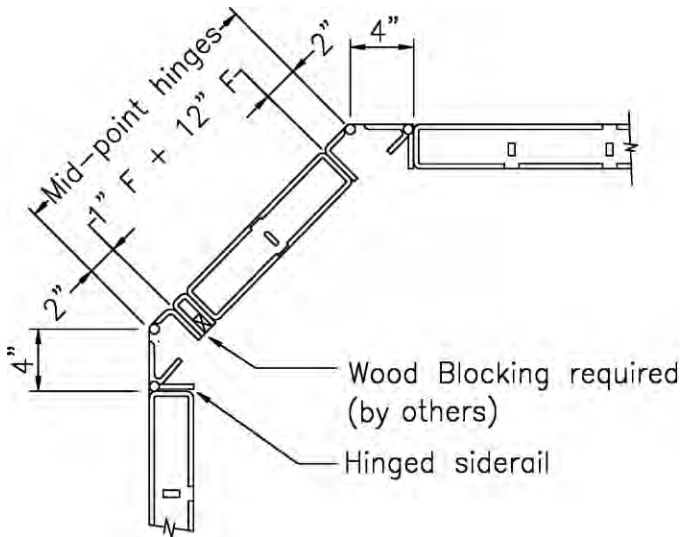

**Double Hinged Filler with Chamfer Corner
(in pour position)**

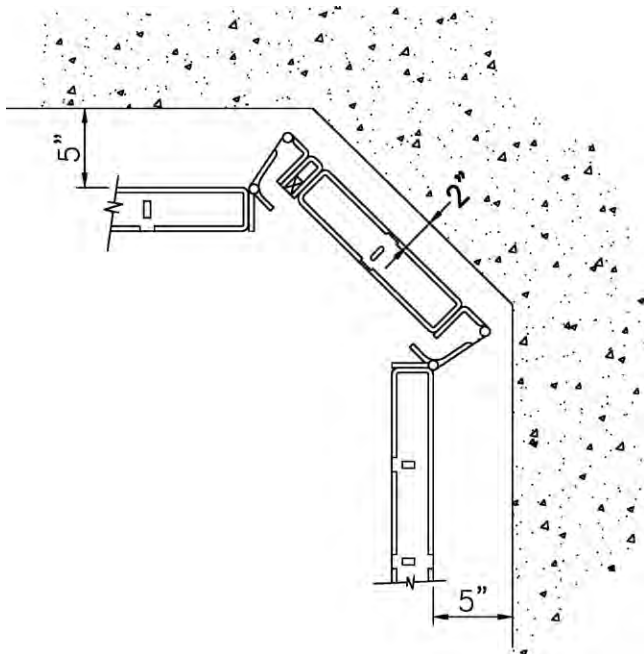

**Double Hinged Filler with Chamfer Corner
(in fold position)**

Application Notes:

- Safe load capacity of the Double Hinged Filler is 500 lbs. per linear ft.
- The 2" face increment rigid side rails of a chamfer pair of Double Hinged Fillers always connect toward each other and together form a 4" portion of the chamfer dimension. Likewise, the 4" face increment hinged side rails always connect to the side wall forms.
- Double Hinged Filler side rails do not contain tie dados.
- All connecting Wedge Bolts must be installed with the tapered end pointing away from the Double Hinged Filler. If they are inadvertently installed with the tapered ends pointing into the Double Hinged Filler, the folding functions of the hinges will be obstructed by the protruding Wedge Bolts (which protrudes 2¾").
- Long Bolts can be used to connect 1", 1½" or 2" steel fillers to the 2" face increment side rail. A Long Bolt may protrude up to 1½" within the Double Hinged Filler without obstructing hinge fold functions. When the Long Bolts are short-stopped to grip through a 1" filler, the short-stop end protrudes 1¾", hence, the Wedge Bolt slot end which protrudes less than 1½" should be at the Double Hinged Filler side of the connection.
- Long Bolts cannot be used to connect 1", 1½" or 2" steel fillers to the Double Hinged Filler at its 4" face increment hinged side rail. Either end of a Long Bolt would protrude and obstruct hinge fold functions.
- When steel fillers are used, wood blocking must be inserted to prevent flexing as the Long Bolts are wedged up tight.

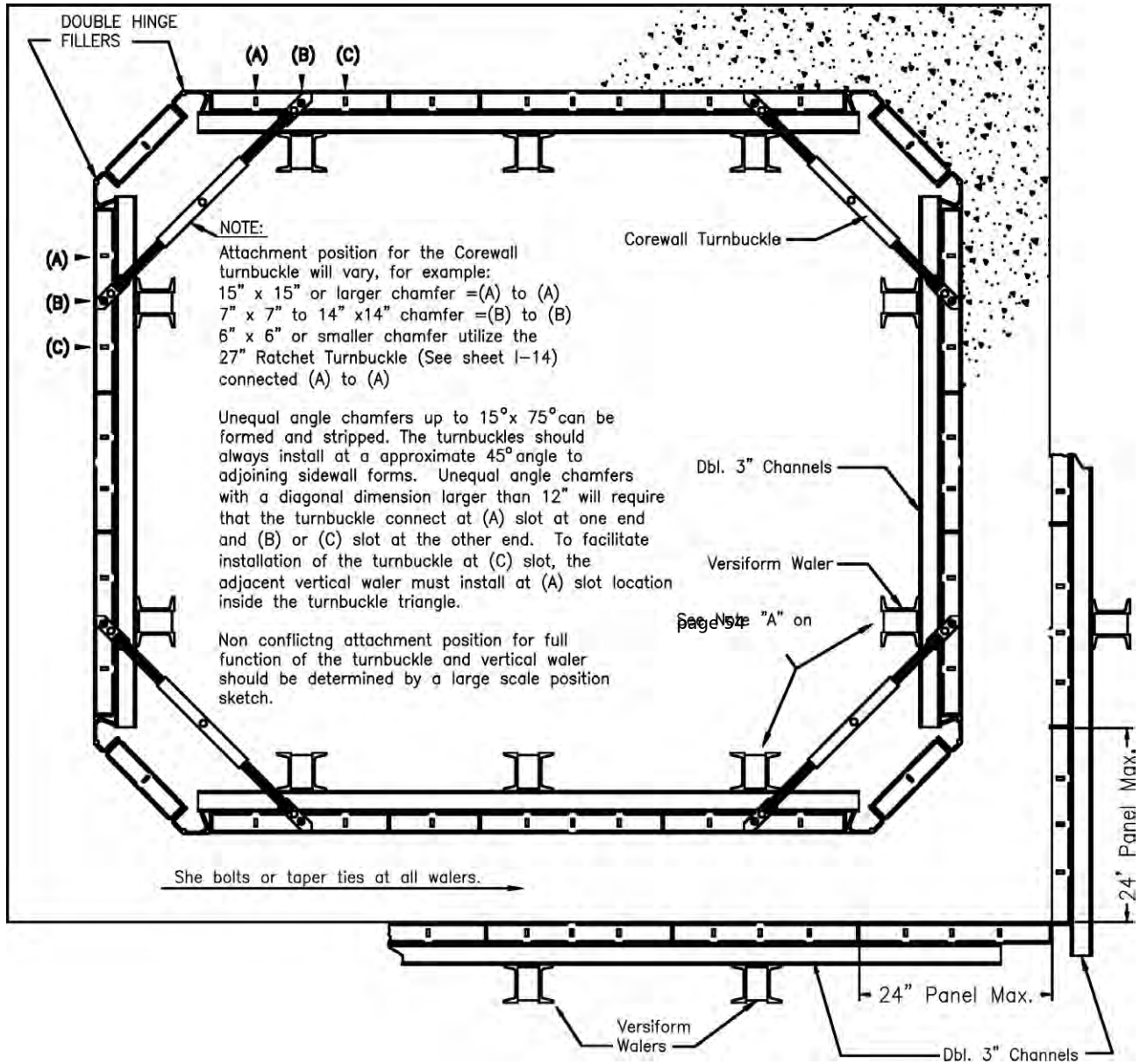

**Double Hinged Fillers with Chamfer Corners
(in pour position)**

Ganged forms may be plumbed into vertical alignment by extending two or more vertical walers or strongbacks down over the previous lift and using the top tie in the previous lift as a pivot point. When Symons Versiform walers are used, the plumbing screw assembly may be used to provide a leverage force at the bottom of the gang.

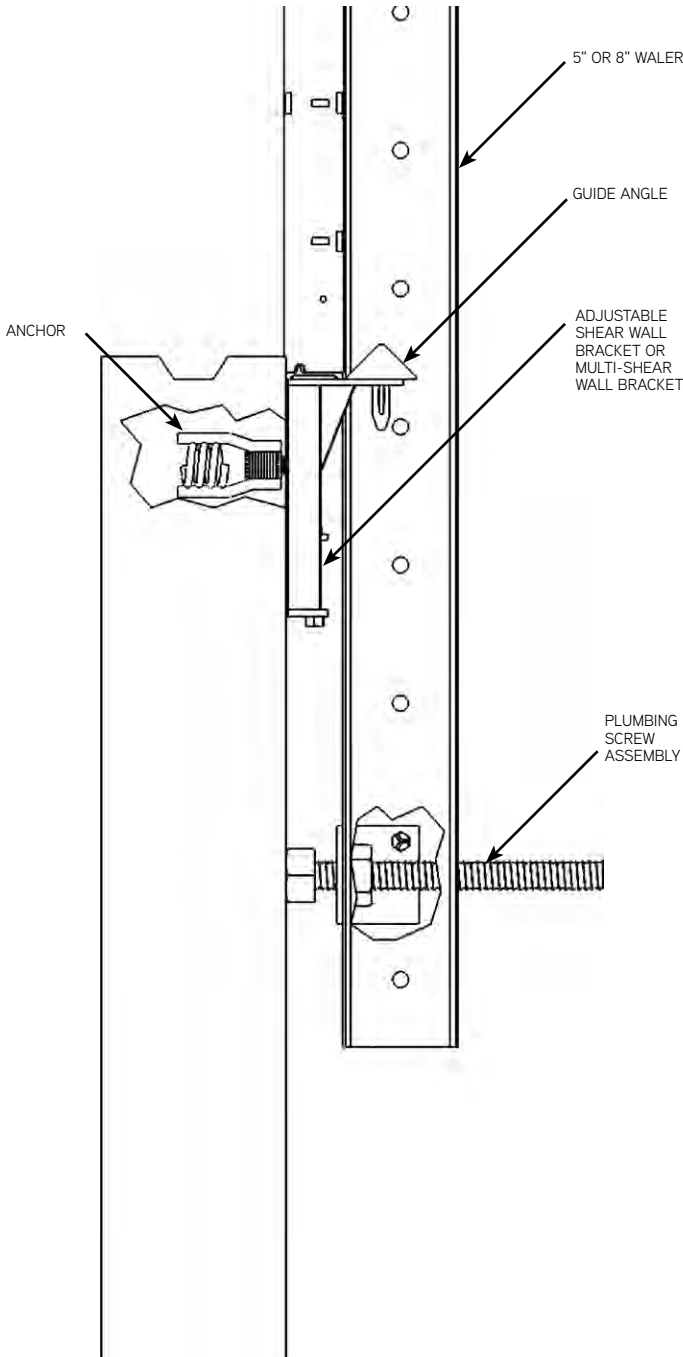

Plumbing Multi-Lift Gangs

COLUMNS

Column Wedge Bolt Positions

Higher pressures due to a faster liquid-head rise are inherent to pouring concrete within the confined lateral dimensions of a column. Also, all side rails must resist lateral side-pull loads that normally are not involved in straight wall panel-to-panel connections. For these reasons, column outside corners require connecting Wedge Bolts at slots adjacent to all panel cross-members, plus at slots 6" from each panel or filler end rail, and at slots 6" from ends of each length of Outside Corner Angle. Form and outside corner lengths are staggered to eliminate common joints.

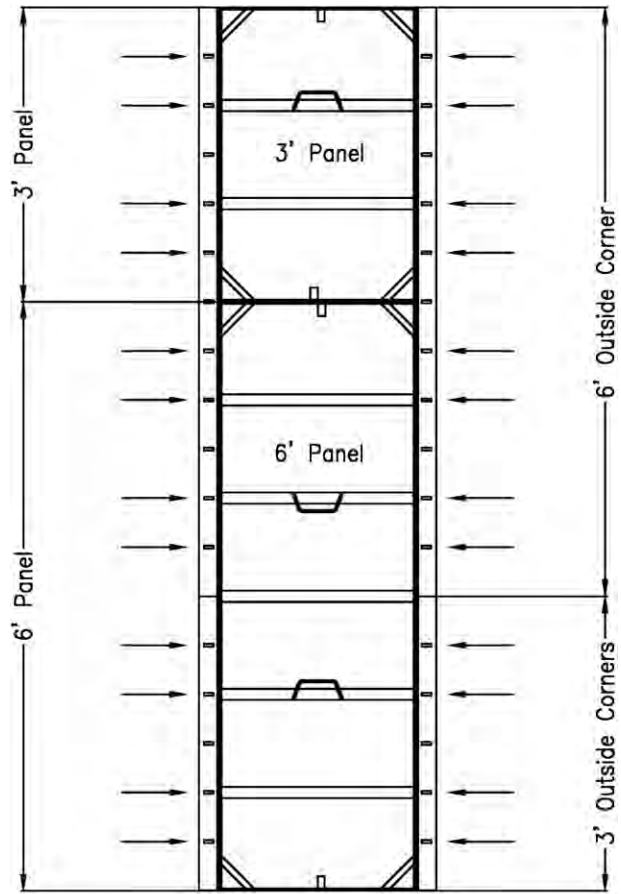

Outside Corner Wedge Bolt Positions for Columns

Adjustable Column Form Extender

The Steel-Ply Adjustable Column Form Extender accommodates uniquely dimensioned monolithic columns and floor slabs without job-building form extensions. The extender adjusts to column widths from 10" to 22" and extends column heights from 2" to 12".

The extension plates slip between Steel-Ply panels or fillers as column forms are assembled. A wood block on top of the form sets the desired extension height. Screw/nail holes are provided 12" O.C. across the top edge for attachment to the plywood deck above. Four extenders, eight standard Wedge Bolts and four wood blocks complete the extension.

The 1/16" thickness of the steel plate creates a slight offset in the form at the top of the column.

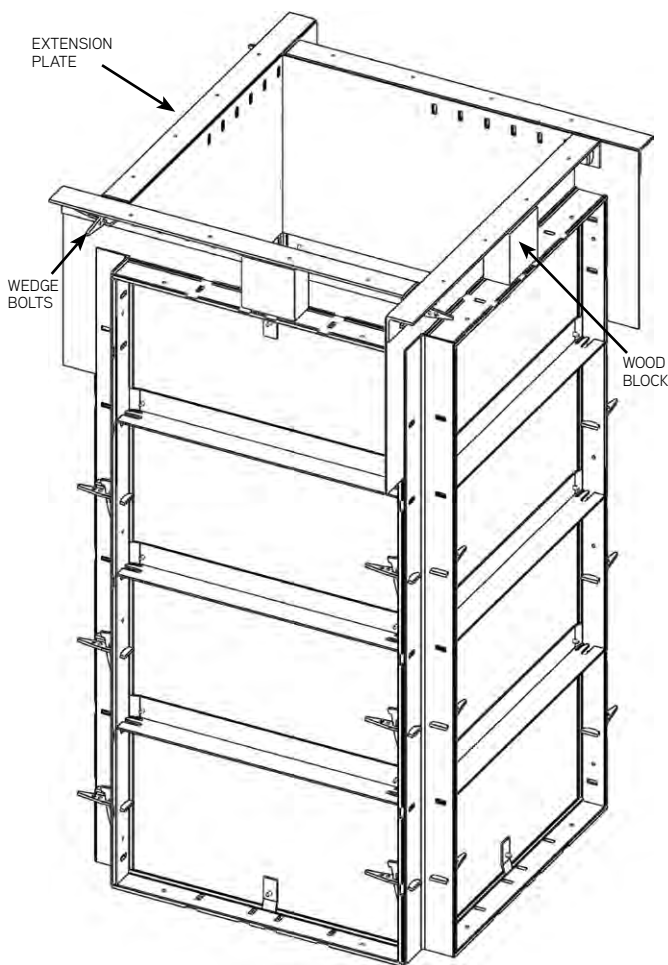

Typical Column Form Extender Application

Column Filler Angle

Used to extend top of column formed with 10" to 24" fillers or panels. Place in a "run-by" manner when column dimensions are under 24".

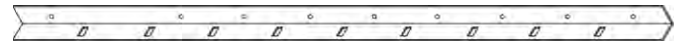

Column Filler Angle Hole and Slot Pattern

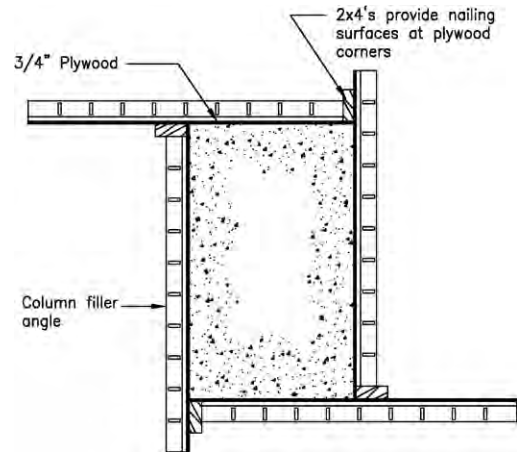

Typical "Run-By" Filler Angle Application

Ganged Columns

Square and rectangular columns may have their four sides ganged with hinges placed in one corner. The hinges are connected to the panel with Wedge Bolts. Other than latching and unlatching the Wedge Bolts on the corner opposite the hinges, the only labor required is bracing and plumbing the ganged unit. Hinges are placed at 1' intervals vertically. This space is increased near the top of the column. Generally, the number of hinges required is column height in feet minus three. The standard Gang Lift Bracket is attached to the top of the ganged form for handling.

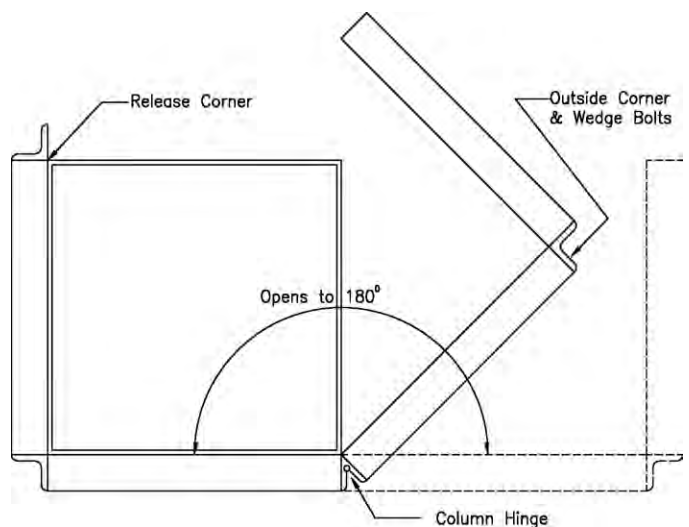

Plan View of Typical Ganged Column

Quick Column Hardware

A Quick Column Hardware Assembly may be used at a column corner in place of four Wedge Bolts. It is attached to one side of an Outside Corner with one Wedge Bolt and the entire assembly stays in place with the ganged column forms. Column hinges at the opposite corner permit easy stripping and resetting of the ganged column form.

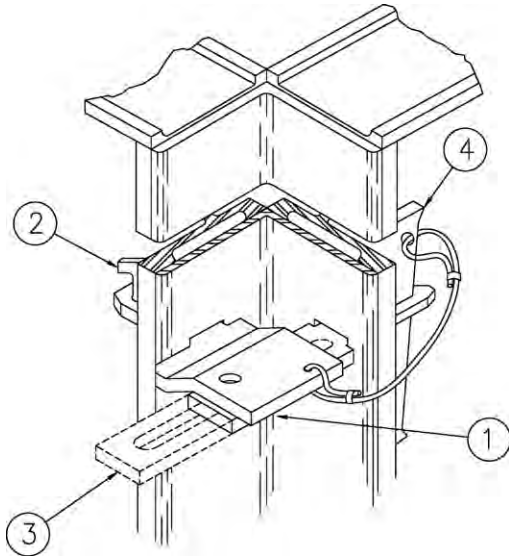

Quick Column Hardware Installation

1. Insert corner latch through Outside Corner (O.C.) and into side rail.
2. Lock hardware assembly to formwork with Wedge Bolt.
3. Insert slide bolt through O.C. and into side rail.
4. Lock column assembly with attached S-Wedge.
5. Spacing is equal to Wedge Bolt spacing.

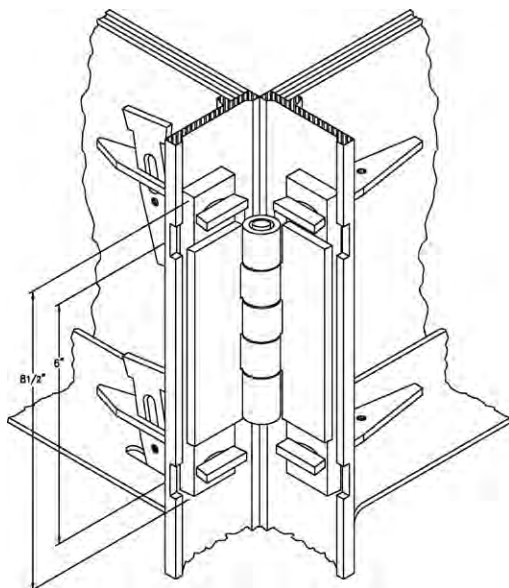

Column Hinge Installation

Column Lift Corner (CLC)

The Column Lift Corner can be used in place of the top two feet of Outside Corner in ganged columns. The Column Lift Corner extends 4" above the column and is secured with 8 Wedge Bolts. Two Column Lift Corners are required per column. It has a safe load capacity of 2000 lbs.

CAUTION: Do not initiate stripping by tugging on the Column Lift Corner.

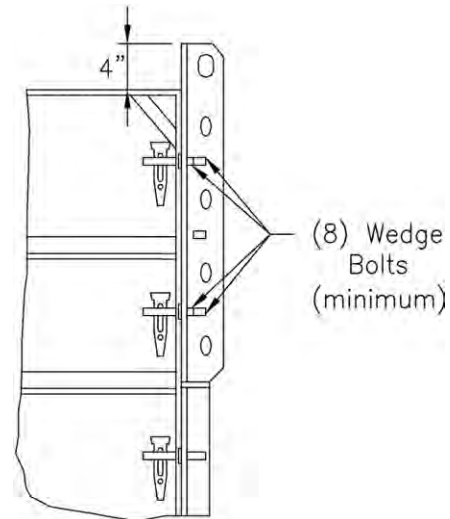
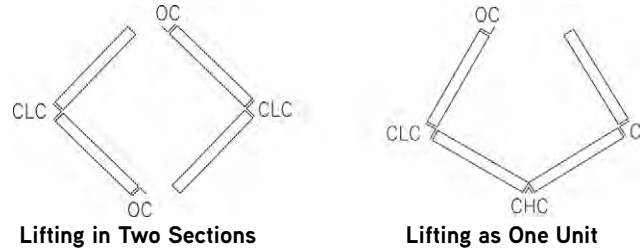

Column Lift Corner Installation

Column Form

An excellent item for rectangular column construction is the 2000 psf Column Form because of the high rates of concrete placement generally associated with column construction. The form can be made in any Steel-Ply panel or filler size and is identical to the standard panels and fillers with the exception of having crossmembers at 6" spacing. Although the form is for purchase only, it can be used as any other panel on the job.

Adjustable Rectangular Column Form

The Adjustable Rectangular Column Form is adjustable for columns up to 30" square, in 1" increments with the exception of 28" and 29" dimensions. For columns 27" or less in either or both cross section dimensions, columns sizes are accommodated by placing the panels in an overlapping manner. Tightening wedges are the only additional hardware required. Three-quarter inch holes must be drilled through the plywood at the appropriate connecting bolt slot in the crossmember. Outside Corners and/or standard panels and filler may be used in conjunction with the Adjustable Rectangular Column Form. For 30" square columns, four outside corners are required. Refer to beginning of this Column section for Wedge Bolt / Outside Corner connecting points.

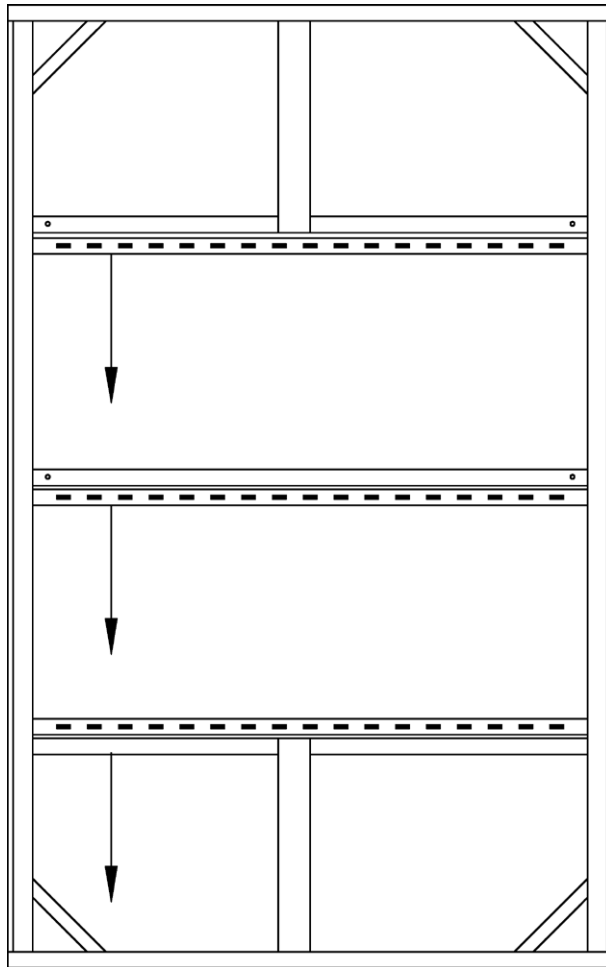

Adjustable Rectangular Column Form

BATTERED WALLS

Battered walls are erected very much like vertical walls, but with two basic differences:

Tie sizes vary to conform to change in vertical wall thickness.

The pressure exerted by freshly placed concrete (liquid) reacts at right angles to form faces. On battered walls, the horizontal component of concrete pressure is accompanied by an upward acting component. This force is called uplift. The amount of uplift force is dependent upon the amount of batter and concrete pressure, and if it is not adequately counteracted, the entire form will "float" out of position. A plate can be added under the battered wall side form to minimize the difference in tie angles relative to both form faces.

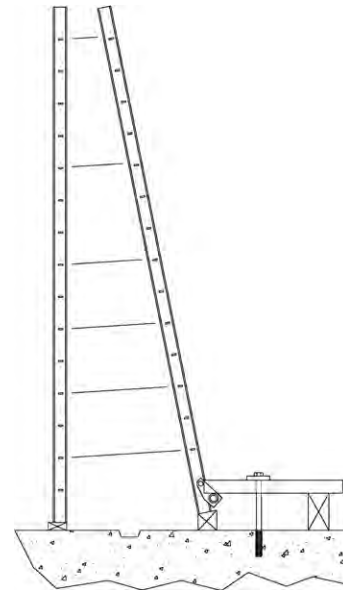

Battered Wall Tie Down

Ganged Steel-Ply may be used for battered wall construction. It is best to load gather the Steel-Ply with the Maxi-Waler or by use of the horizontal Steel-Ply method. When this is done, Taper or She-Bolt type of ties are used with Batter Plate Washers and the Cast Contour Nuts. The Batter Plate Washer has a spherical surface, and the washer has a matching spherical surface.

Most battered walls can be erected with batter washers on only one side of the wall; however, batters over 4:12 should be erected with batter washers on both sides of the wall.

Battered walls may be erected with ganged forms using straight panel ties if the total batter of both wall sides does not exceed 3:12. When this batter exceeds 3:12, it is possible to use panel ties, but one or both ends of the tie will have to be pre-bent at the form surface. Because the ties have to be twisted when broken off to remove the gang, it is most likely that the bent tie will break outside of the concrete surface rather than at the breakback location within the concrete wall.

Any battered form will have a vertical component of pressure-causing uplift. The forms must be weighted or tied down to prevent "float" of the form as concrete is placed. In most cases, it is not possible to accurately predict the uplift force; however, your Symons Account Manager will be able to give a reasonable estimate of this force depending on amount of batter, height of wall and anticipated maximum placing pressure.

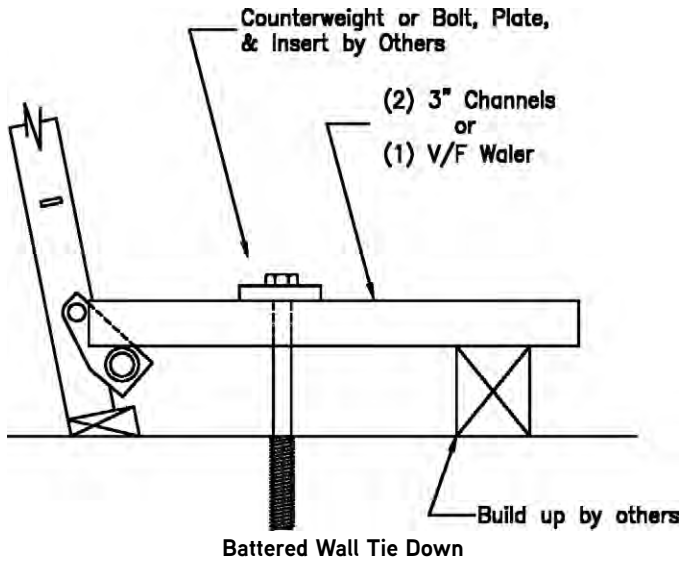
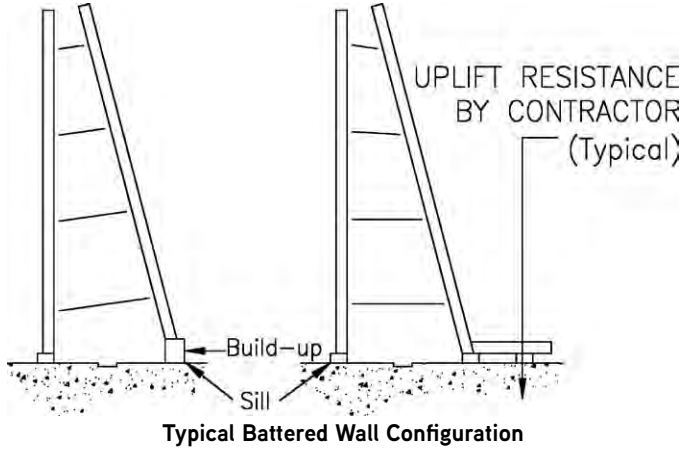

Batter Tie Down Bracket

The Batter Tie Down Bracket attaches to the Steel-Ply side rail 6" from the bottom of the form using a Transition Bolt and 5/8" nut. Do not use Wedge Bolts or Long Bolts for attachment. Lumber or a Versiform® waler must be placed on both legs of the bracket. The bracket must be loaded equally on both legs: capacity of the bracket is relative to the wall slope. Refer to the chart, below.

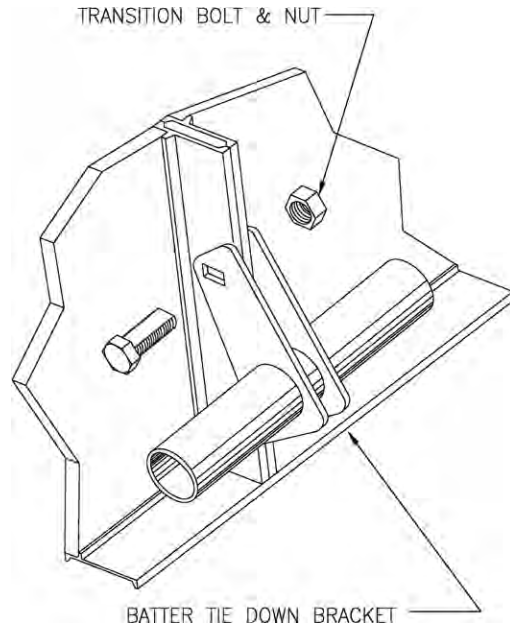

Batter Tie Down Bracket Installation

FORM SLOPE	WORKING LOAD PER BRACKET
0:12 TO 6:12	8650 LBS
6:12 TO 9:12	7690 LBS
9:12 TO 12:12	7450 LBS

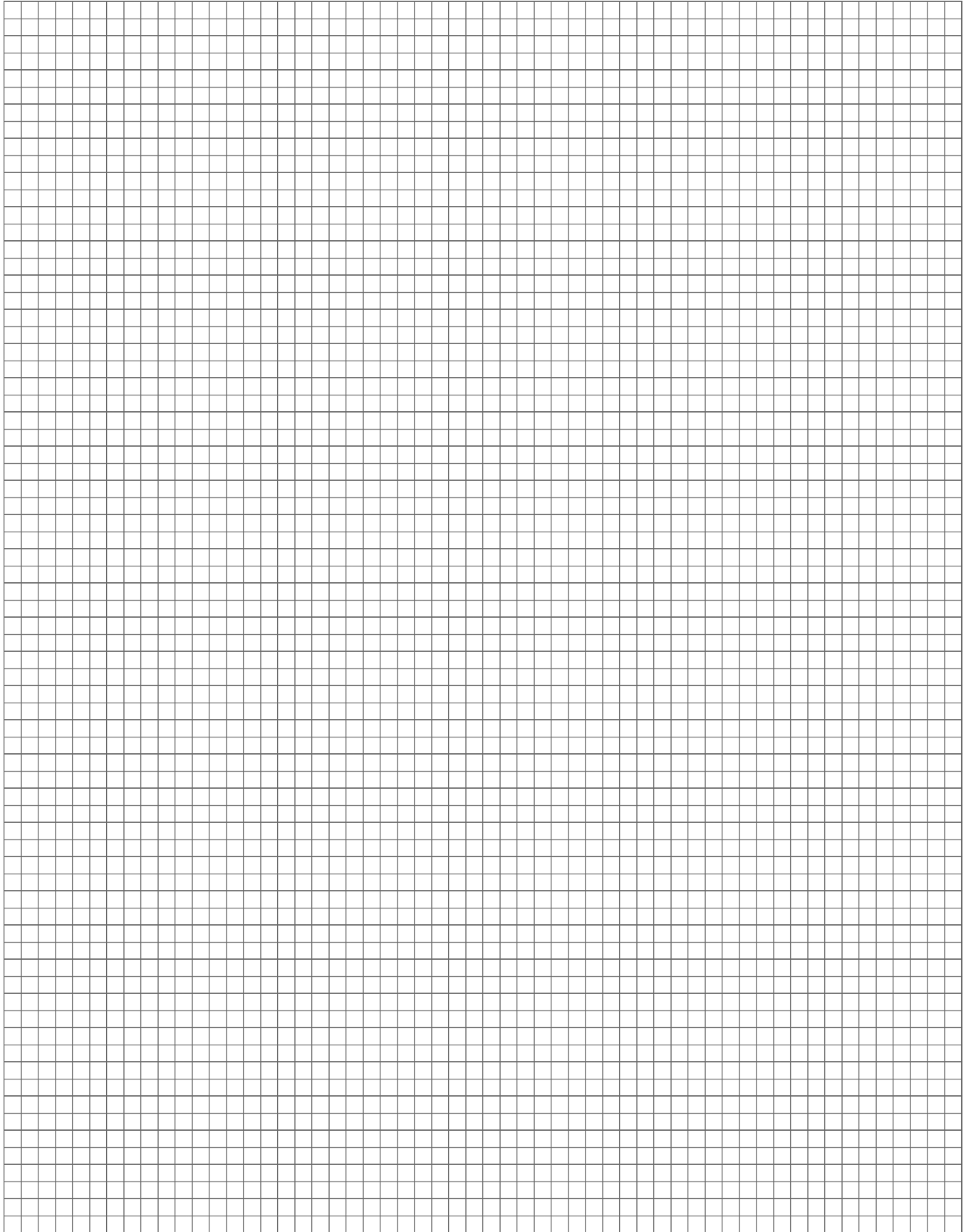

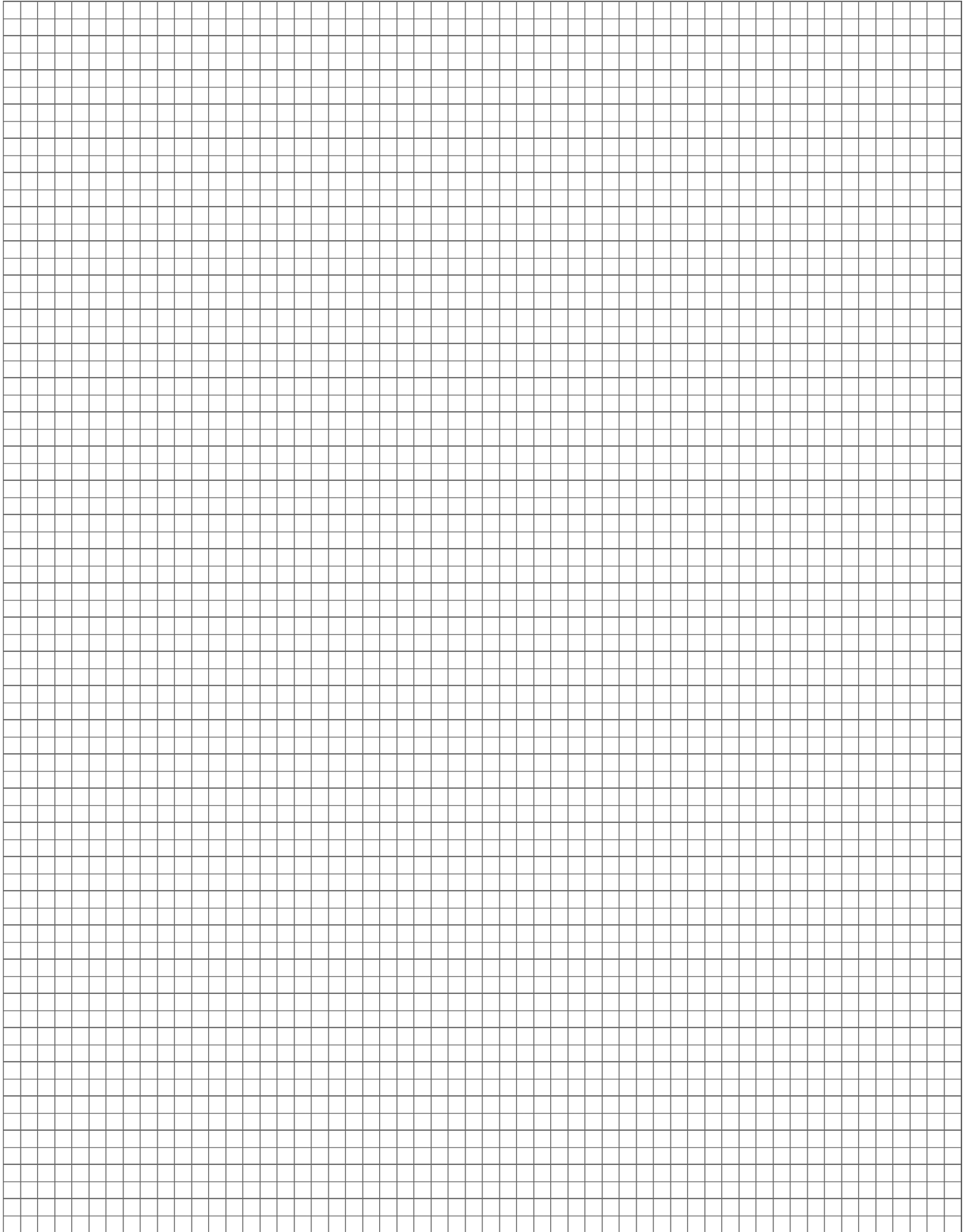

INDEX

#1 Cone Ties.....7
 #2A Cone Tie.....8
 #2 Cone Ties.....7
 3" Aligner Channel.....10, 39
 3" Channel Aligner Bracket.....10, 39
 5" Double Channel Waler.....43
 5" Versiform Waler.....44
 8" Versiform Waler.....45
 27" Ratchet Turnbuckle.....54
 45° Splice Channel.....46
 45° Waler.....46

A

Accessories.....9
 Adapter Plug.....31
 Adjustable Column Form Extender.....59
 Adjustable Flat Tie.....5
 Adjustable Long Bolt.....3
 Adjustable Rectangular Column Form.....61
 Adjustable Shear Wall Bracket.....31
 Adjustable Single End Threaded Tie.....6
 Adjustable Top Tie.....50
 Aligner Bracket.....10
 Aligner Channel.....10, 39
 Anchor Bolt.....31
 Anchor Insert.....31
 Angle Support Plate.....18
 Assembling Gangs.....33
 Assembly of Maxi-Waler Gang.....49

B

Base Tie Bolt.....8
 Battered Walls.....61
 Batter Plate Washer.....61
 Batter Tie Down Bracket.....62
 Bay Corner.....12
 Bay Corner Brackets.....12
 Beam Pocket.....16
 Box Culvert.....13
 Breakback.....4
 Brick Ledge Bracket.....16
 Bulkhead.....25

C

Cantilever Bracket.....17
 Cantilever Clip.....17
 Capacity, Ties.....5
 Cast Bearing Washer.....50
 Chamfer Corner Corewall.....56
 Channel Aligner Bracket.....39
 Column Filler Angle.....59
 Column Form.....60
 Column Form Extender.....59
 Column Hinge.....60

Column Lift Corner.....60
 Columns.....58
 Column Wedge Bolt Position.....58
 Cone Tie.....7, 35
 Conventional Gang Forming.....33
 Core Forming.....53
 Culvert Form.....13
 Curved Gang Forming.....37
 Curved Wall.....35

D

Double Channel Waler.....43
 Double Duty Lift Bracket.....40
 Double Hinged Filler.....53
 Double Pilaster Tie.....8

E

Erection Procedure.....22

F

Fast-Pin.....17
 Filler.....2
 Fit-Up Bolt.....45
 Flat Tie.....5
 Footing Corner Bracket.....20
 Footing Forming.....20
 Form Aligner.....14
 Form Alignment.....35
 Form Extension Bracket.....17

G

Ganged Columns.....59
 Ganged Core Forming.....53
 Ganged Forming.....33
 Gang Form Adapter Sleeve.....37
 Gang Form Bolt.....33
 Gang Form Tie.....34
 Gang Lift Bracket.....40
 Gang Waler Plate.....34, 39
 Gang Waler Rod.....10, 34, 39, 43, 49
 Guide Bolt.....31



H

Handles.....1
 Haunch Support Bracket.....18
 Heavy Duty Tie.....5
 Hinged Corner.....13
 Horizontal Gang Alignment.....38
 Horizontal Gang Assembly.....43

I

Inside Bay Corner.....12
 Inside Hinged Corner.....13
 Intersecting Walls.....26

J		Sloped Footings.....	24
Job Built Filler	4	Special Ties	6
J-Strongback Hook	28	S-Pilaster Tie.....	8
J-Strongback Waler Rod.....	49	Splice Channel.....	46
		Spreader Clip.....	50
K		Square Corner Corewall	54
Keeper Bolt	6	Stacking Forms	29
		Stake Plate.....	20
L		Steel Filler.....	3
Lifting Core Forms	53	Stepping Forms	24
Lifting Waler.....	52	Stripping.....	4
Long Bolt.....	3	Strongbacks.....	28
“L” Washer.....	49	Strongback Tie	28
M		T	
Maxi-Waler	61	Taper Tie.....	42
Maxi-Waler Gang	49	Threaded Tie.....	5
Multi-Shear Wall Bracket	32	Tie Alignment.....	5
		Tie Breakback	4
O		Tie Capacity	5
One-Piece Waler Clamp	27	Tie Removal.....	35
Outside Bay Corner	12	Ties.....	5
Outside Corner Angle.....	58	Tie Spacing.....	5
Outside Hinged Corner.....	13	Tie Threaded Both Ends	6
		Toggle Tie.....	5
P		Transition Bolt and Nut	62
Panel	1	Turnbuckle Aligner	15
Panel Tie.....	5		
Panel Waler Connector.....	43, 52	U	
Pilaster Brace	11	U-Bolt.....	29, 39
Pilaster Form.....	10		
Pipe Aligner Hook.....	9, 38	V	
Pipe Form Aligner	15	Versiform Waler	15, 42, 44, 45
Pipe Waler	9	Vertical Strongback.....	39
Pre-Bent Tie.....	9		
		W	
Q		Waler Connector	52
Quick Column Hardware.....	60	Waler Lift Bracket.....	45, 51
		Walers	27, 44
R		Waler Splice Channels.....	45
Ratchet Turnbuckle.....	54	Waler Tie.....	27
Ratchet Turnbuckle, Ganged Core Forms.....	53	Wall Corners	25
Rectangular Column Form.....	61	Wedge Bolt.....	2
S		Y	
Safety Eye.....	1	“Y” Wall.....	46
S-Base Tie.....	5, 9		
Scaffold Bracket	16	Z	
Second Lift Forming.....	30	Z-Tie Holder.....	7, 27, 28
She-Bolt Tie.....	42		
Short Bolt.....	10		
Siderail Crossbar	51		
Sill Plate.....	20		
Single End Threaded Tie.....	6		
Single End Threaded Toggle Tie.....	7		

	<div data-bbox="688 306 1354 394"> WARNING</div> <div data-bbox="643 424 1398 499"><h3>Improper Use of Concrete Forms and Shores Can Cause Severe Injury or Death</h3></div> <div data-bbox="602 506 1438 642"><p>Read, understand and follow the information and instructions in this publication before using any of the Dayton Superior concrete accessories displayed herein. When in doubt about the proper use or installation of any Dayton Superior concrete accessory, immediately contact the nearest Dayton Superior Service Center or Technical Service Department for clarification. See back cover for your nearest location.</p></div>
---	---

Dayton Superior products are intended for use by trained, qualified and experienced workmen only. Misuse or lack of supervision and/or inspection can contribute to serious accidents or deaths. Any application other than those shown in this publication should be carefully tested before use.

The user of Dayton Superior products must evaluate the product application, determine the safe working load and control all field conditions to prevent applications of loads in excess of a product's safe working load. Safety factors shown in this publication are approximate minimum values. The data used to develop safe working loads for products displayed in this publication are a combination of actual testing and/or other industry sources. Recommended safe working loads given for the products in this publication must never be exceeded.

Worn Working Parts

For safety, concrete forms must be properly used and maintained. Concrete products shown in this publication may be subject to wear, overloading, corrosion, deformation, intentional alteration and other factors that may affect the device's performance. All reusable products must be inspected regularly by the user to determine if they may be used at the rated safe working load or should be removed from service. The frequency of inspections depends upon factors such as (but not limited to) the amount of use, period of service and environment. It is the responsibility of the user to schedule inspections for wear and remove the hardware from service when wear is noted.

Shop or Field Modification

Welding can compromise a product's safe working load value and cause hazardous situations. Knowledge of materials, heat treating and welding procedures is necessary for proper welding. Consult a local welding supply dealer for assistance in determining required welding procedures.

Since Dayton Superior cannot control workmanship or conditions in which modifications are done, Dayton Superior cannot be responsible for any product altered in the field.

Interchangeability

Many concrete products that Dayton Superior manufactures are designed as part of a system. Dayton Superior strongly discourages efforts to interchange products supplied by other manufacturers with components supplied by Dayton Superior. When used properly, and in accordance with published instructions, Dayton Superior products have proven to be among the best designed and safest in the industry. Used improperly or with incompatible components supplied by other manufacturers, Dayton Superior products or systems may be rendered unsafe.

Installation

WARNING

1. Dayton Superior Corporation products shall be installed and used only as indicated on the Dayton Superior Corporation installation guidelines and training materials.
2. Dayton Superior Corporation products must never be used for a purpose other than the purpose for which they were designed or in a manner that exceeds specific load ratings.
3. All instructions are to be completely followed to ensure proper and safe installation and performance
4. Any improper misuse, misapplication, installation, or other failure to follow Dayton Superior Corporation's instruction may cause product malfunction, property damage, serious bodily injury and death.

THE CUSTOMER IS RESPONSIBLE FOR THE FOLLOWING:

1. Conformance to all governing codes
2. Use of appropriate industry standard hardware
3. The integrity of structures to which the products are attached, including their capability to safely accept the loads imposed, as evaluated by a qualified engineer.

SAFETY INSTRUCTIONS:

All governing codes and regulations and those required by the job site must be observed. Always use appropriate safety equipment

Design Changes

Dayton Superior reserves the right to change product designs, rated loads and product dimensions at any time without prior notice.

Note: See Safety Notes and Safety Factor Information.



**PERFORM
WITH
PRECISION**

F
FORMTECH
concrete forms, inc.

48575 Downing Street
Wixom, MI 48393
800.876.4857 | info@formtechinc.com
formtechinc.com

SYM111
05/16

Give us a call at any of our branch locations, email us at info@formtechinc.com, or click on formtechinc.com/quote to get a quote. Our experienced Form Tech representatives will answer your questions, and help you get your project started with some of the best concrete forming, shoring, and accessory products in the industry, backed by a professional and detail-oriented staff.



Charleston, SC

7377 Peppermill Lane
North Charleston,
SC 29418
843.628.3434



Detroit, MI

Corporate Headquarters
975 Ladd Road
Walled Lake,
MI 48390
Branch: 248.344.8260
Corporate: 248.344.8265



Charleston, WV

161 Industrial Road
St. Albans,
WV 25177
304.722.6804



Pittsburgh, PA

2850-A Kramer Road
Gibsonia,
PA 15044
412.331.4500



Charlotte, NC

1000 Thomasboro Road
Charlotte,
NC 28208
704.395.9910



Raleigh, NC

115 Peffinder Lane
Raleigh,
NC 27603
919.833.0911



Cleveland, OH

20801 Miles Road
North Randall,
OH 44128
216.692.0497



TRUSTED FORMWORK & ACCESSORY SPECIALISTS
800-876-4857 | info@formtechinc.com | formtechinc.com