



The FrameFast shoring system is engineered for maximum strength, labor productivity and reuse capabilities. The system includes Heavy Duty Shore Frames, Adjustable Post Shores, and Aluminum Beams. These products are available in a wide range of sizes for virtually any deck forming application. A variety of special features and accessories make them fast and easy to use.

F **FORMTECH**
concrete forms, inc.

800.876.4857 formtechinc.com

CONTENTS

| | |
|---|-----------|
| I. INTRODUCTION | 1 |
| II. SYSTEM DESCRIPTIONS | 2 |
| FrameFast Shore Frame System | 2 |
| Heavy Duty Post Shore System | 2 |
| III. BASIC COMPONENTS and INSTALLATION | 2 |
| Plywood | 2 |
| Joist and Connection Hardware | 2 |
| Symons Aluminum Joist | 3 |
| SW Aluminum Joist | 3 |
| Symons Aluminum Beam | 3 |
| SW Aluminum Stringer | 4 |
| ShorFast Beam | 4 |
| Steel Stringers — W8x10..... | 4 |
| Connections for Joists | 5 |
| Symons Aluminum Joist and Beam) | 5 |
| SW Joist and SW Stringer..... | 5 |
| Symons Aluminum Joist and Beam, and SW Joist and SW Stringer..... | 5 |
| Stringer and Connection Hardware..... | 5 |
| Connecting Slot Method (Fig. 9) | 5 |
| U-Head and Steel Beam Clamp Method (Fig. 11-1 and 12-1)..... | 5 |
| U-Head and Wood Block Method (Fig. 11-2)..... | 6 |
| Aluminum Attachment Clip Method (Fig. 11-3) | 6 |
| Versiform Friction Bolt Method (Fig. 11-4) | 6 |
| Support System and Accessories..... | 7 |
| Heavy Duty Base Plate | 8 |
| 8"x8" U-Head Adapter | 8 |
| 8"x8" 7-Hole U-Head..... | 9 |
| FF/SF Sloping Head Assembly..... | 9 |
| Crossbraces and Spacer Bars | 9 |
| FF/SW Coupling Pin | 11 |
| HD Coupling Pin..... | 11 |
| Timber Brace Nailer Plate | 11 |
| 4"x8" U-Head | 13 |
| 5"x8" J-Head | 13 |
| Post Shore Timber Brace Nailer Plate..... | 13 |
| IV. ERECTION PROCEDURES | 14 |
| Site Preparation | 14 |
| Erection on Flat Surface | 14 |
| Erection on Sloped Surface | 16 |
| V. INSPECTION | 17 |
| Material Inspection | 17 |
| Field Erection Check With Symons Shoring Layout..... | 17 |
| Inspection During Pour | 18 |
| VI. REMOVAL OF SHORES AND RESHORING | 18 |

I. INTRODUCTION

Shoring is a temporary structure, designed to carry the weight of fresh concrete, reinforcing steel and formwork, and the live loads imposed during construction.

Attention to safety is particularly important in shoring, as these structures support the concrete, not only during its plastic state, but until the concrete becomes structurally self-sufficient.

Since many shoring failures have been attributed to some human error or omission, rather than basic inadequacy in design, a thorough understanding of each component and its function before erection, along with the careful supervision and continuous inspection during and after erection and pouring, can prevent many accidents.

We strongly recommend that construction procedures be planned in advance by the contractor to insure the safety of personnel engaged in formwork and concrete placement, and the integrity of the finished structure.

Refer to The Occupational Safety and Health Administration (OSHA) publication 29 CFR 1926—Subpart Q, “Concrete, Concrete Floors, and Shoring” safety standard and any other appropriate regulations, codes and ordinances.

It is the contractor’s responsibility to provide adequate support against the liquid pressures and live loads present, as well as provide for wind loads and footing limitations. Failure to do so could result in a concrete/grout “blow-out” or shoring collapse, subjecting workers to the risk of serious injury or death, and causing job delays and rework.

NOTE: Photographs are for illustrative purposes only. Consult applicable codes and standards for compliance of shoring erection.

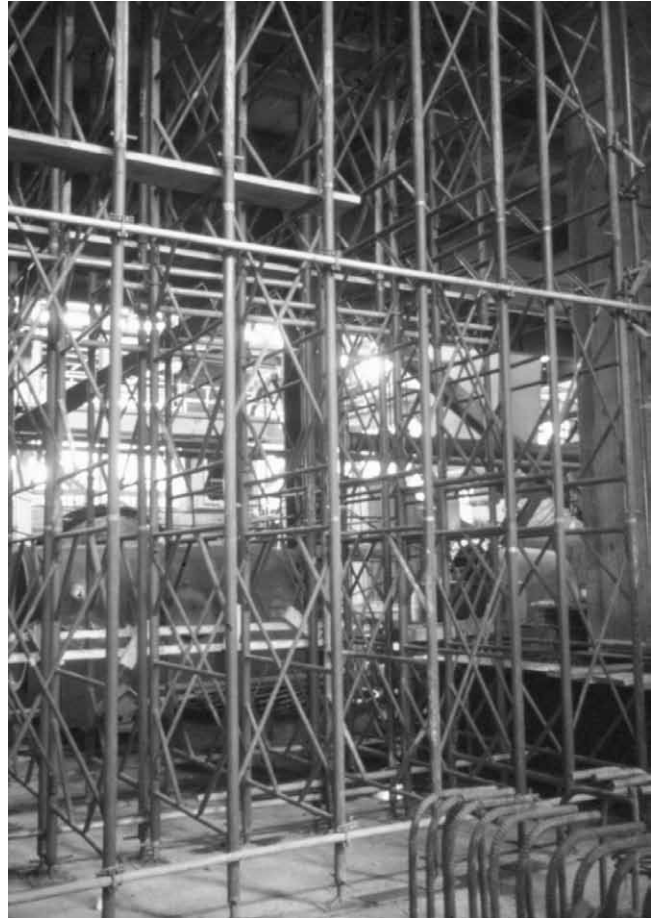

II. SYSTEM DESCRIPTIONS

CAUTION: Frames and accessories manufactured by others must not be intermingled with Symons frames, as different safety factors and dimension tolerances may be used, and may result in failure.

FrameFast Shore Frame System

Shoring frames are used to support the imposed loads. The frames are connected to each other with cross braces, forming a rigid tower to provide maximum stability and strength in virtually any shoring application. The frames can also be stacked together, to meet virtually any height requirement, using coupling pins. For this system, adjustable screw jacks are used to provide leveling, fine adjustment in height, and stripping clearance. Jacks can be used at top or bottom of the shore frames, or at both locations.

Heavy Duty Post Shore System

A Post Shore is a one-piece load-carrying member, much like a column. This type of shoring has been used in concrete construction for many years. Post shores made of lumber, with separate accessories, have a low-load carrying capacity. Therefore, many of them are required to do a simple job.

Symons Heavy Duty Post Shores provide high load ratings without sacrificing the convenience and versatility of the Post Shore System. Furthermore, they have a built-in adjustment feature to facilitate the handling. This shore can be used by itself or in combination with the FrameFast System.



III. BASIC COMPONENTS AND INSTALLATION

Plywood

Probably the most widely used sheathing material for shored deck is $\frac{3}{4}$ " plywood. $\frac{3}{4}$ " grade B-B Plyform, Class I, is commonly used for sheathing material, but for many reuses and high load carrying capacity, high-density overlaid plywood is recommended.

Plywood sheathing acts like a beam, but the plies running perpendicular to the span contribute little to the bending strength and stiffness of the panel. Generally the grain direction of the outer layers is parallel to the long dimension of the panel. Therefore, the plywood should be used in such a way that the outer layer grain runs parallel to the span, i.e., the grain should run perpendicular to the joist member direction.

Because, in many cases, the plywood strength and stiffness govern the joist spacing, the selection of the plywood and the placement of the plywood joints should be given careful consideration, depending on the job conditions.

Joist and Connection Hardware

A joist is defined in shoring as a member directly supporting the plywood or sheathing material. Several different types of material may be used as a joist member.

1. Lumber and Nailer Clip

Lumber is a common joist material, usually having 2" x 4", 2" x 6", or 4" x 4" sections. Like plywood, there are several different species and each one has a different load carrying capacity. As a guide, a Symons Representative provides the shoring layout with lumber joist spacing based on the strength specified on the layout drawings. The contractor should adjust this spacing based on the condition and grade of lumber that he has, if its quality is different from that specified.

CAUTION: Lumber condition and grade, as well as the integrity of any shoring layout utilizing lumber, is the responsibility of the contractor. Refer to the appropriate lumber and/or plywood standards, specifications or practices published by the American Plywood Association and the National Forest Products Association.

When rolling or skidding of the shoring units is required, use nailer clips to fasten the wood joists to the stringers (Figs. 1 and 8). This enables the decking to drop with the shoring during stripping.

CAUTION: Do NOT use the nailer clip as uplift resistance to cantilever joists.

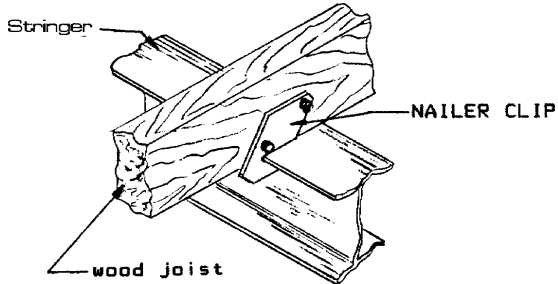

Fig. 1

2. Aluminum Joists, Beams and Stringers

Symons offers several styles of high-strength, light-weight, aluminum extruded members for horizontal support.

Symons Aluminum Joist

This member (Fig. 2) is 6½" deep with top and bottom flanges that are 4" wide. A 1½ x 1½" plastic nailer strip is secured in the top flange of the member and a continuous connecting slot runs the length of the bottom flange. The joist weighs 4 lbs per lineal foot. It can be used as a joist or as a stringer.

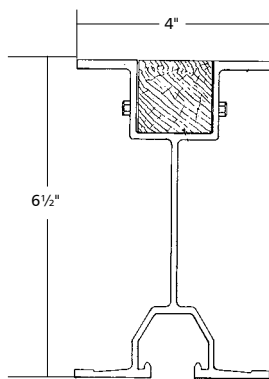

Fig. 2

SW Aluminum Joist

This member (Fig. 3) is 6½" deep with a 3" top and 4" bottom flange. A 1½ x 1½" plastic nailer strip is secured in the top flange of the member and a continuous connecting slot runs the length of the bottom flange. The connecting slot is smaller than the Symons joist so a smaller T-bolt is used for connections. The joist weighs 4.2 lbs per lineal foot. It can be used as a joist or as a stringer.

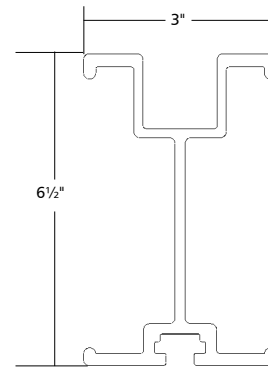

Fig. 3

Symons Aluminum Beam

This member (Fig 4) is 7¼" deep with top and bottom flanges that are 5" wide. A 1½ x 1½" plastic nailer strip is secured in the top flange of the member and a continuous connecting slot runs the length of the bottom flange. The beam weighs 5 lbs per lineal foot. It can be used as a joist or as a stringer. When used as a stringer, it must butt in the U-Heads as the 5" flange does not allow it to lap in an 8" x 8" U-Head.

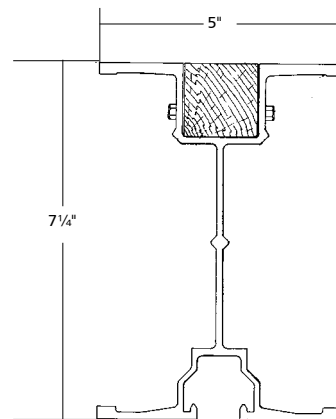

Fig. 4

SW Aluminum Stringer

This member (Fig. 5) is 7½" deep with top and bottom flanges that are 4" wide. A 1½" x 1½" plastic nailer strip is secured in the top flange of the member and a continuous connecting slot runs the length of the bottom flange. The connecting slot is smaller than the Symons joist, so a smaller T-bolt is used for connections. The stringer weighs 5.3 lbs per lineal foot. It can be used as a joist or as a stringer.

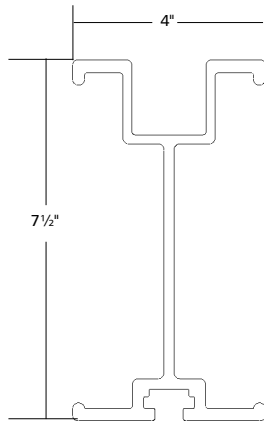

Fig. 5

ShorFast Beam

This member (Fig. 6) is 22.5cm (8⅞") deep with top and bottom flanges that are 10cm (4") wide. It has a continuous connecting slot running the length of the top and bottom flange. It is used only as a stringer, as it has no nailer in it. The connecting slot is larger than the joists, beams and stringers above, so a T-Bolt, Aluminum Attachment Clip and ½"-13 NC Hex Nut are used for connections. The beam weighs 5.8 lbs per lineal foot.

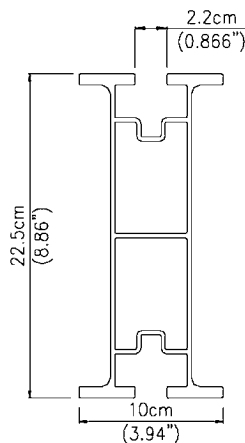

Fig. 6

Steel Stringers — W8x10

This member (Fig. 7) is 8" deep with top and bottom flanges of 4". It is an all steel section used only as a stringer. The beam weighs 10 lbs per lineal foot.

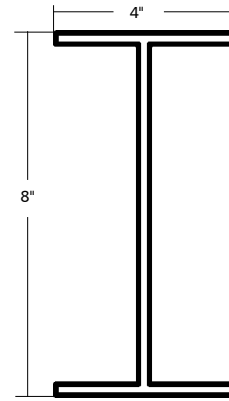

Fig. 7

3. Connections

The Aluminum Attachment Clip attaches Aluminum Beams and Aluminum Joists to the stringer member when moving shoring, as detailed in Fig. 3.

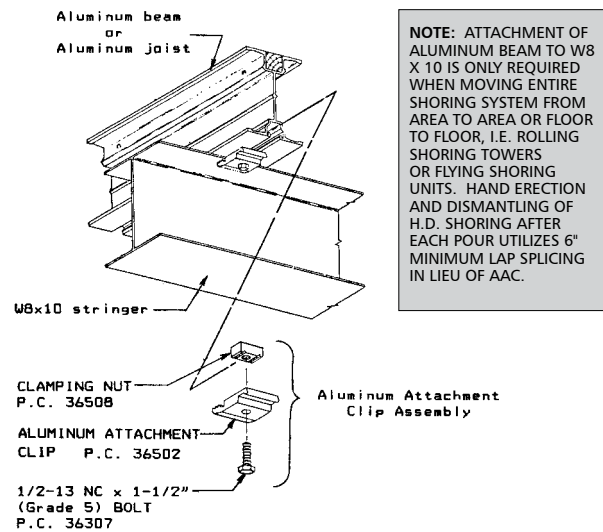

Fig. 8

Because of the special clamping nut, it can be inserted at any point along the beam, simplifying the connection. A Clip Assembly consists of one Attachment Clamp, one ½" diameter bolt, and one Special Clamping Nut (Fig. 3). Only two clips are required for a given length of the beam or joist in most applications.

One edge of the clip has a lip that curls over a flange with raised edges. The opposite side of the clip has serrations and a ribbed projection to provide a secure clamping and holding action when used on a flat flange. Both sides of the Attachment Clip have flat surfaces adjacent to the holding areas to prevent rotation of the clip.

To attach the Aluminum Beam/Joist to W8x10 steel stringers, put the Aluminum Attachment Clip Assembly as shown and insert the Clamping Nut into the bottom slot of the beam near the connection point. Place the Attachment Clip serrated surface against stringer flange and turn the bolt. Once the Clamping Nut positions against the beam slot, the bolt can be tightened.

To attach the Aluminum Beam/Joist to the Aluminum Beam Stringer, use the same method, except place the lip side of the Attachment Clip toward the Aluminum Stringer. Connections for Joists

Connections for Joists

Symons Aluminum Joist and Beam)

These members (Figs. 3 and 4) can be connected to a stringer by using an Aluminum Attachment Clip, 1½" x ½"-13 NC Bolt and a Clamping Nut. (Fig. 9) The design of the nut is such that the assembly of these three parts can be inserted anywhere along the connecting slot. A ¾" socket, box or open end wrench tightens the connection.

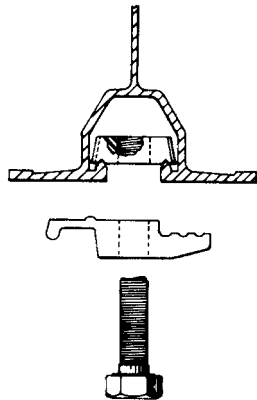

Fig. 9

SW Joist and SW Stringer

These members can be connected to a stringer by using an Aluminum Attachment Clip, an All Joist T-Bolt, and a ½"-13 NC Hex Nut (Fig. 10). The design of the bolt is such that the assembly of these three parts can be inserted anywhere along the connecting slot. A ¾" socket, box or open end wrench is used to tighten the connection. An A-Clamp Assembly (Figure G) is also an acceptable connecting method.

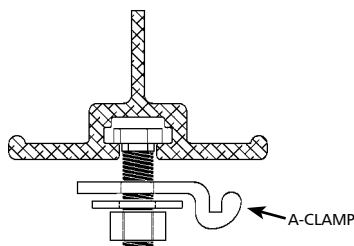

Fig. 10

Symons Aluminum Joist and Beam, and SW Joist and SW Stringer

To minimize different hardware when combinations of these members are used on a project an Aluminum Attachment Clip, an All Joist T-Bolt and a Clamping Nut will work on all of them. The secure connections with an open-end adjustable wrench.

Stringer and Connection Hardware

A stringer is the member which supports the joists, and usually runs perpendicular to the joist direction. It is the element of the decking that transmits the total load to the shore frame. Several materials can be used for this member. The stringer has to be securely connected to the shore head to prevent overturning.

Connecting Slot Method (Fig. 9)

If U-Heads are not used, stringers must pass completely over or butt over the center of the 8" x 8" plate of the Meter Screw Jack. Members with connecting slots can be secured as described in the previous section to the plate of the screw jack. Two alternate methods are also available.

U-Head and Steel Beam Clamp Method (Fig. 11-1 and 12-1)

If stringers are to be lapped in an 8" x 8" U-Head, a Steel Beam Clamp can be used to secure the flanges to the u-head. A clamp is required at each end of every stringer. Aluminum Joists and Stringers, ShorFast Beams and W8x10's can all be secured by this method. Any member with a 5" flange such as the Aluminum Beam will not lap in the 8" x 8" U-Head.

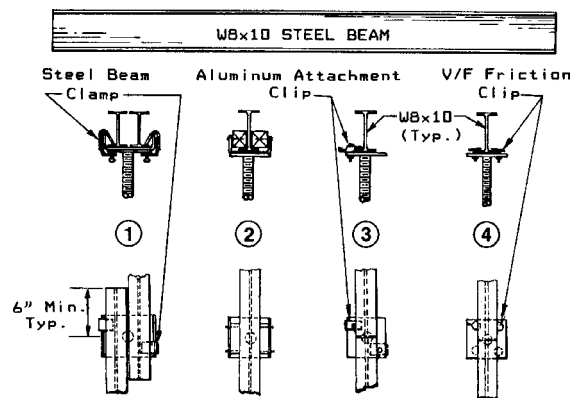

Fig. 11

U-Head and Wood Block Method (Fig. 11-2)

If stringers are to be lapped in an 8" x 8" U-Head, wood blocks can be used to secure the flanges to the u-head. Blocks are required on both sides at each end of every stringer. The blocks are secured with screws or nails through the holes in the upturned legs of the U-Head. Aluminum Joists and Stringers, ShorFast Beams and W8x10's can all be secured by this method. Any member with a 5" flange such as the Aluminum Beam will not lap in the 8" x 8" U-Head.

Aluminum Attachment Clip Method (Fig. 11-3)

Stringers with 4" or 5" wide bottom flanges can be connected to the Meter Screw Jack by using an Aluminum Attachment Clip on the flange and passing a 1 1/2" x 1/2"-13 NC Bolt through the hole in the screw jack plate and securing with a 1/2"-13 NC Hex Nut. Two connections are required at each plate.

Versiform Friction Bolt Method (Fig. 11-4)

Stringers with 4" wide bottom flanges can be connected to the Meter Screw Jack by using a Versiform Friction Bolt on the flange and passing through the hole in the screw jack plate and securing with a 1/2" Contour Nut. Four connections are required at each plate.

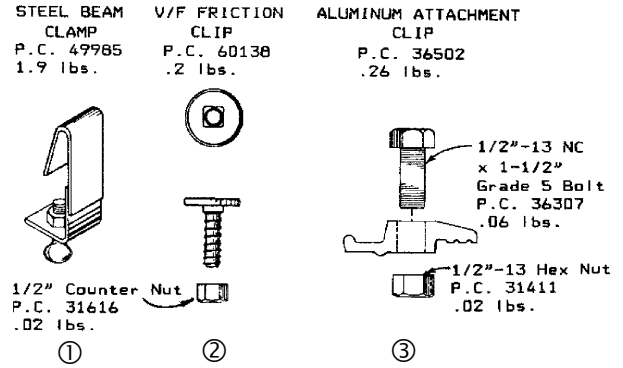

Fig. 12

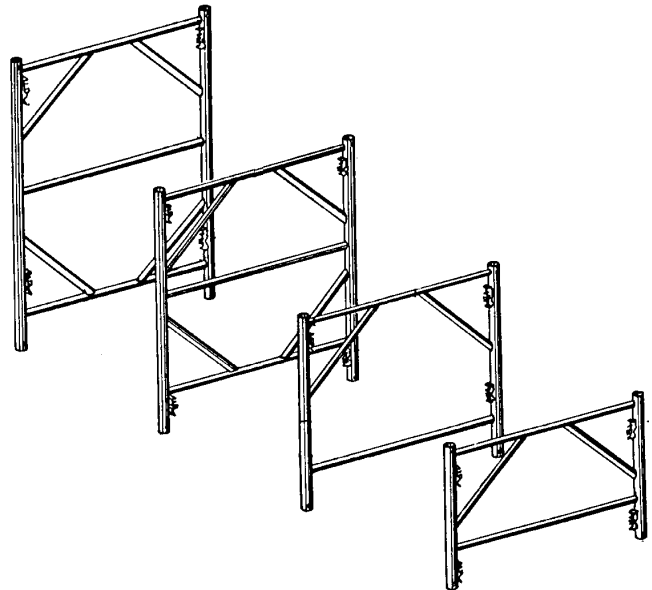

Fig. 13

Support System and Accessories

1. FrameFast Shoring Frames

Symons FrameFast Shoring Frames (Fig. 14) are rated for 12,000 lbs. safe load per leg, up to two tiers high. Of course this load will be increased or decreased depending on the actual number of tiers used and total extension of the jacks. Refer to layout drawings for maximum shore leg capacities. This frame can be adapted to virtually any shoring condition, through the use of other accessories. The 2' and 4' wide frames have the same load capacity.

CAUTION: The two styles of frames, FF and SW, must never be used on the same tower.

Symons crossbrace locking devices, which are a part of the frame, permits FrameFast Shore Frames to be erected and dismantled quickly. It locks in position up to two crossbraces and one spacer bar. This unique locking arrangement securely holds the frames together, providing tower rigidity and safety.

SW Shoring Frames — There are 6 standard sizes of frames available as shown in Fig. 14. Holes at each end of SW legs are $1\frac{1}{16}$ " diameter. Crossbrace studs are located either 7" or 13" from the top of the frame legs.

FF Shoring Frames — There are eight standard sizes of frames available as shown in Fig. 14. Older FF frames may have diagonal structural tubes supporting the top ledger on 3' and 4' high frames, and the top and bottom ledgers of 5' and 6' high frames. Holes at each end of the FF legs are $\frac{5}{8}$ " diameter. Crossbrace studs are located $6\frac{1}{4}$ " from the top of the frame legs.

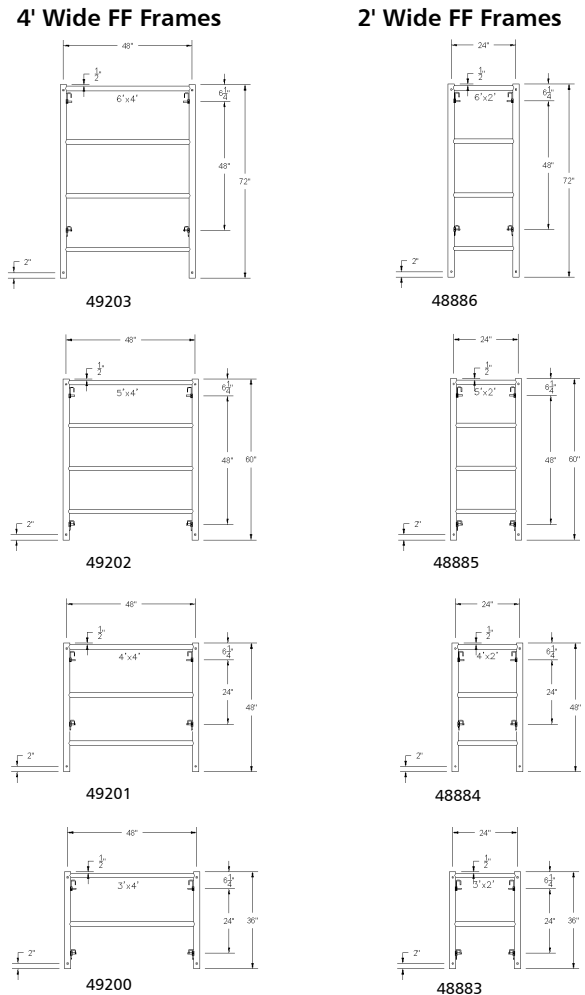
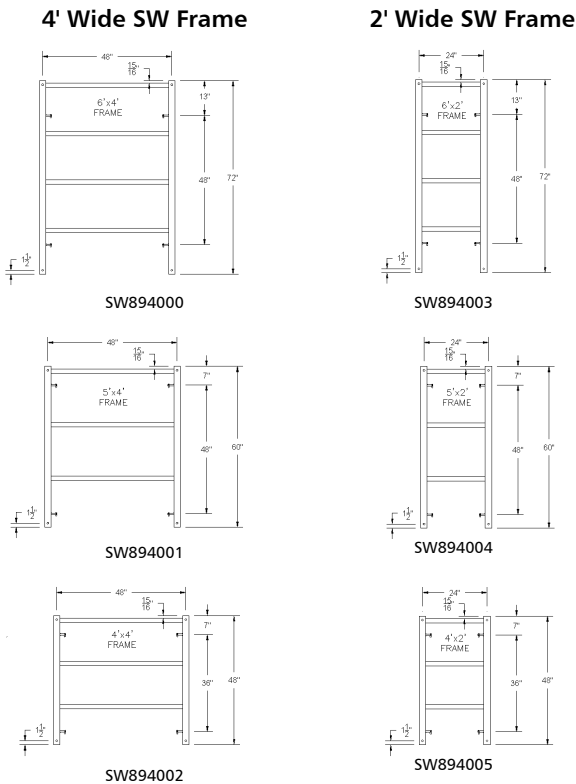

Fig. 14

2. Meter Screw Jack

The screw jacks are used for leveling, fine adjustment in elevation, and stripping clearance. The Meter Screw Jack (Fig. 15) is a full meter ($39\frac{3}{8}$ " in length with 1.9" OD, and provides a maximum extension of $27\frac{3}{8}$ ", longest in the industry. As a result, total adjustment range is $25\frac{1}{4}$ ", from $2\frac{1}{8}$ " to $27\frac{3}{8}$ ".

An 8" x 8" base plate is welded to the jack as a unit, so the jack can be used at top of the shore leg or at bottom. The plate has four holes which are used to clamp the W8x10 stringer using the Versiform Friction Clamp, or Aluminum Attachment Clip, as described earlier. These holes are also used to attach the 8" x 8" U-Head Adapter.

CAUTION: When used at both top and bottom of the shore leg, be sure there is a minimum shoring height of 6'-8" for a one frame high tower so that the ends of the screw will not touch inside of the leg. Also, when used with 3' high frames, be sure there is enough extension of the jack not to touch the Coupling Pin or the Base Plate. A minimum 2" of downturn thread should always be available below the height adjustment position to facilitate deck form release. If jacks are used at top and bottom, the 2" minimum thread dimension can be accrued from both.

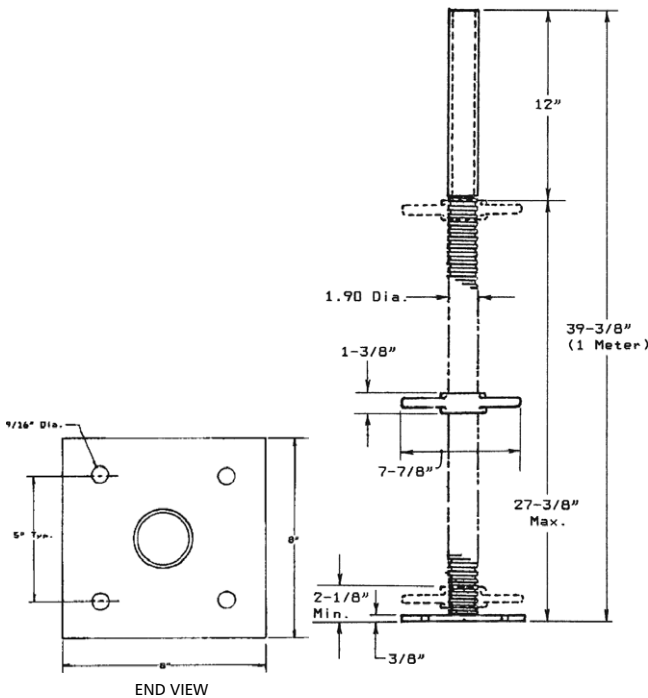

Fig. 15

Heavy Duty Base Plate

The Heavy Duty Base Plate (Fig. 16) has a 8" x 8" x $\frac{3}{8}$ " dimension and distributes leg load, providing a firm footing for the shoring tower. Some applications may require its use at the top of a tower, in which case, the 8" x 8" U-Head Adapter may be bolted to it, since it has the same pattern of holes.

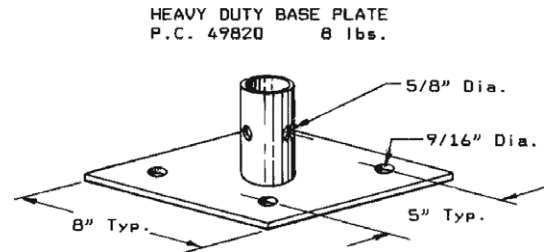

Fig. 16

8"x8" U-Head Adapter

The U-Head Adapter (Fig. 17) or Aluminum Joist stringer are used with the Meter Screw Jack when the W8x10 stringers are lapped side by side at the shore head. Like the Meter Screw Jack, the adapter has four holes and is attached using two (2) flathead machine screws in diagonal holes. The Steel Beam Clamp secures the stringer to the U-Head.

NOTE: When lap splicing W8x10 steel stringers, a machine screw and nut must be placed in each of the four holes and wrench tightened.

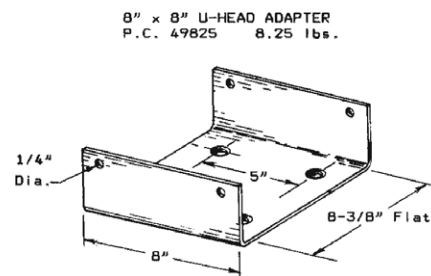

Fig. 17

CAUTION: Do not use stringers in such a manner as to place an eccentric load on the U-Head Adapter.

This adapter can also be used with the Heavy Duty Base Plate (Fig. 18), where no screw is used at the top of the shore head. The connection is same as to the Meter Screw Jack.

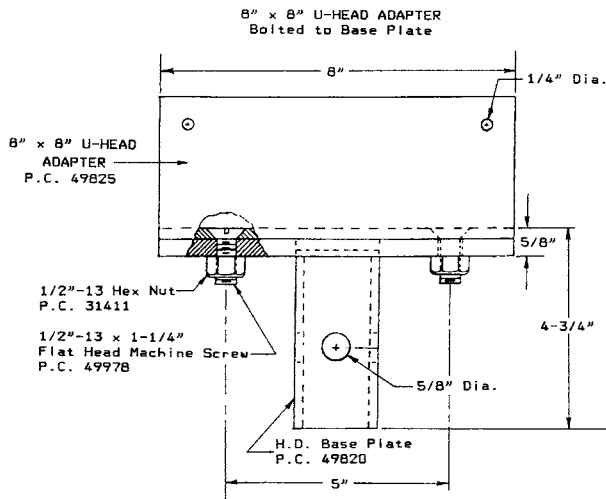

Fig. 18

8"x8" 7-Hole U-Head

The 7-Hole U-Head performs the same functions as the 8" x 8" U-Head Adapter, but it can also be used with Symons ShorFast system.

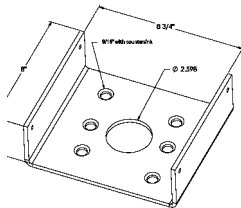

Fig. 19

FF/SF Sloping Head Assembly

Adapts for sloped ceilings and floors for angles up to 45°. It bolts to Base Plates or Meter Screw Jacks with two 1/2" bolts and nuts. Lateral bracing may be required in sloped conditions.

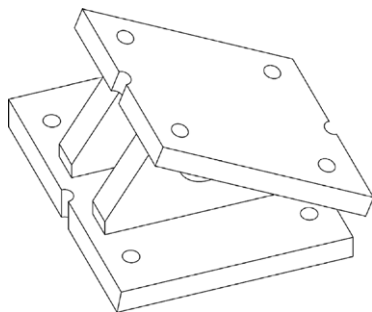

Fig. 20

Crossbraces and Spacer Bars

Crossbraces (Fig. 21) are used to connect frames together to make a tower, and give it stability. They provide many different frame spacings from 3' to 12' (Fig. 16). They are manufactured from steel angle or from 1" OD tubular steel up to 10' spacing and 1 1/4" OD for 12' spacing. The ends of braces are flattened and have a 9/16" hole to connect to the frames. The crossbraces are inserted onto the stud of the frame and locked by the locking device. Crossbraces are designed for use with 24", 36" or 48" stud center spacings. For example, while a CB48 crossbrace gives an 8' frame spacing on 6' and 5' high frames, it will give an 8'-8 5/8" frame spacing on 3' high frames.

Double Hole Crossbraces may be used with 36" or 48" stud spacings. The outer holes are used for the 48" stud center, and the inner holes are used for the 36" center frames.

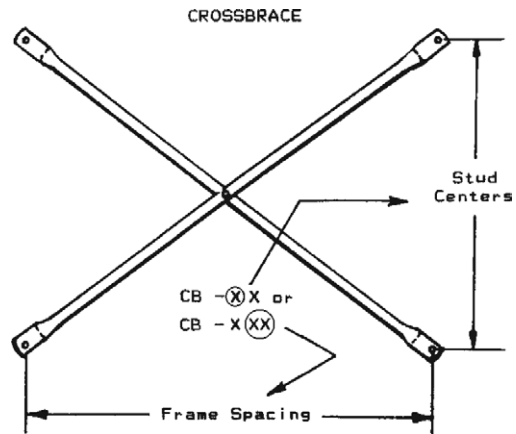

Fig. 21

| FRAMEFAST SYSTEM | | Center to center frame spacing in feet | | | Brace hole to hole distance (inches) | weight (lbs.) |
|--|--------------|--|----------------------------------|--|--------------------------------------|---------------|
| | | 3' & 4' high FF frames 2' stud center | 4' high SW frames 3' stud center | 5' & 6' high FF & SW frames 4' stud center | | |
| CB size | Product Code | | | | | |
| CB23 | 49255 | 3 | ---- | ---- | 43.27 | 5.5 |
| CB24 | 49035 | 4 | 3.32 | ---- | 53.67 | 7.3 |
| CB25 | 49038 | 5 | 4.47 | 3.61 | 64.62 | 8.5 |
| CB26 | 49068 | 6 | 5.57 | 4.9 | 75.89 | 9.5 |
| CB27 | 49031 | 7 | 6.63 | 6.08 | 87.36 | 11 |
| CB28 | 49027 | 8 | 7.68 | 7.21 | 98.95 | 13.5 |
| CB210 | 49042 | 10 | 9.75 | 9.38 | 122.38 | 16.3 |
| CB212 | 48875 | 12 | 11.79 | 11.49 | 145.99 | 26.5 |
| CB215 | 48876 | 15 | 14.83 | 14.59 | 181.59 | 33.5 |
| CB43 | 49256 | 4.58 | 4 | 3 | 60 | 7.8 |
| CB44 | 49037 | 5.29 | 4.8 | 4 | 67.88 | 8.8 |
| CB45 | 49040 | 6.08 | 5.66 | 5 | 76.84 | 9.5 |
| CB46 | 49041 | 6.93 | 6.56 | 6 | 86.53 | 11 |
| CB47 | 49033 | 7.81 | 7.48 | 7 | 96.75 | 13 |
| CB48 | 49094 | 8.72 | 8.43 | 8 | 107.33 | 15 |
| CB410 | 49096 | 10.58 | 10.34 | 10 | 129.24 | 17 |
| CB412 | 49297 | 12.49 | 12.29 | 12 | 151.79 | 28 |
| CB415 | 49296 | 15.39 | 15.23 | 15 | 186.29 | 35 |
| Spacing Using Outer Holes of DHCB | | | | | | |
| DHCB44 | SW894013 | 5.29 | 4.8 | 4 | 67.88 | 9.4 |
| DHCB45 | SW894012 | 6.08 | 5.66 | 5 | 76.84 | 10.6 |
| DHCB46 | SW894011 | 6.93 | 6.56 | 6 | 86.53 | 11.3 |
| DHCB47 | SW894010 | 7.81 | 7.48 | 7 | 96.75 | 13.2 |
| DHCB48 | SW894009 | 8.72 | 8.43 | 8 | 107.33 | 14.6 |
| DHCB410 | SW894008 | 10.58 | 10.34 | 10 | 129.24 | 17.4 |
| Spacing Using Inner Holes of DHCB | | | | | | |
| DHCB44 | SW894013 | 4.58 | 4 | 3 | 67.88 | 9.4 |
| DHCB45 | SW894012 | 5.48 | 5 | 4.24 | 76.84 | 10.6 |
| DHCB46 | SW894011 | 6.4 | 6 | 5.39 | 86.53 | 11.3 |
| DHCB47 | SW894010 | 7.35 | 7 | 6.48 | 96.75 | 13.2 |
| DHCB48 | SW894009 | 8.31 | 8 | 7.55 | 107.33 | 14.6 |
| DHCB410 | SW894008 | 10.25 | 10 | 9.64 | 129.24 | 17.4 |
| Spacing Using Outer Holes of CB | | | | | | |
| CB33 | 49256 | 3.74 | 3 | ---- | 50.91 | 5.5 |
| CB35 | 49040 | 5.48 | 5 | 4.24 | 69.97 | 8 |
| CB36 | 49041 | 6.4 | 6 | 5.39 | 80.5 | 10 |
| CB37 | 49033 | 7.35 | 7 | 6.48 | 91.39 | 11 |
| CB38 | 49094 | 8.31 | 8 | 7.55 | 102.53 | 14 |

Fig. 22

Spacer bars (Fig. 23) also connect frames together, but provide only a 12", 18", or 24" spacing, and are used horizontally, not diagonally. Spacer bars cannot be used by themselves to make a tower. Therefore, they have to be used in conjunction with the cross braced tower for an add-on frame (Fig. 24). When very heavy load is imposed, the frames can be put closer together to support the required load by this means. One add-on frame requires four spacer bars to connect to the crossbraced one.

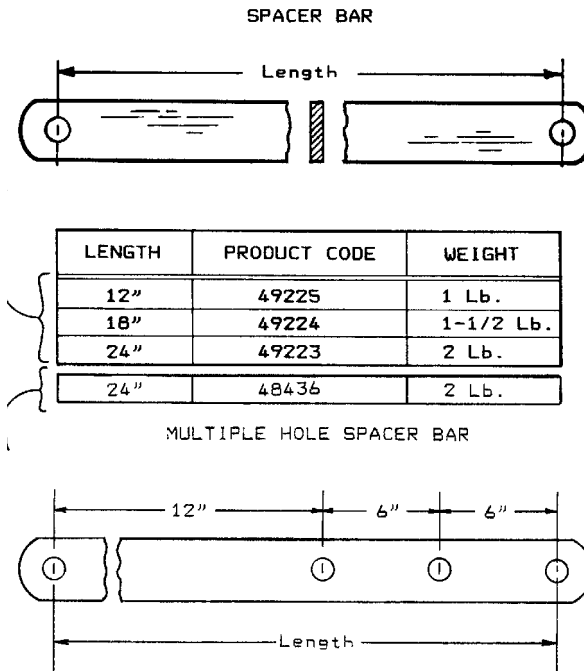

Fig. 23

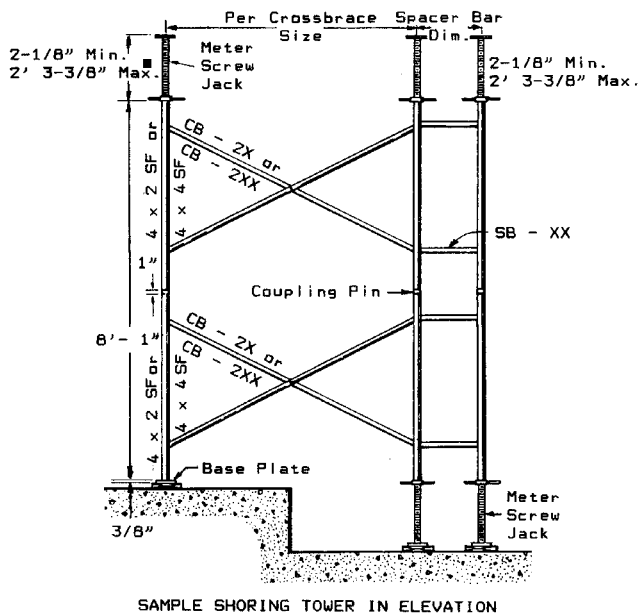

Fig. 24

FF/SW Coupling Pin

The FF/SW Coupling Pin is used for FF or SW style frames. Place the tapered portion upward for easy erection and stripping. Each coupling pin adds 1" in shore height due to the leg bearing ring plate. When used with FF style frames, two 1/2" Attachment Pins and two Hairpin Clips are needed to secure the pin if required. When used with SW frames, the Coupling Pin can be secured with two 5/8" Rivet Pins and two Hairpin Clips if required.

HD Coupling Pin

Symons Heavy Duty Coupling Pin (Fig. 25) is used to align and connect the FF style frames together in multi-tier shore tower assembly. Place the tapered portion upward for easy erection and stripping. Each coupling pin adds 1" in shore height due to the leg bearing ring plate.

Attachment or Rivet Pins and Hairpin Clips are used together with a Coupling Pin in each hole if the tower is to be lifted guyed, or is six or more tiers high. It is required on each leg connection for every tier.

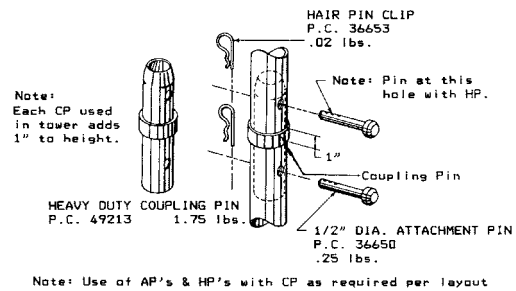

Fig. 25

Timber Brace Nailer Plate

The Timber Brace Nailer Plate (Fig. 26) permits the use of any width lumber (2" x 6" min.) to brace shore legs or post shore staffs of 2 3/8" O.D., providing a quick, friction connection. A minimum of four 16d nails (clinched over in back) per clip are required.

This plate enables lumber to be used for bracing multi-tiered towers together to increase stability.

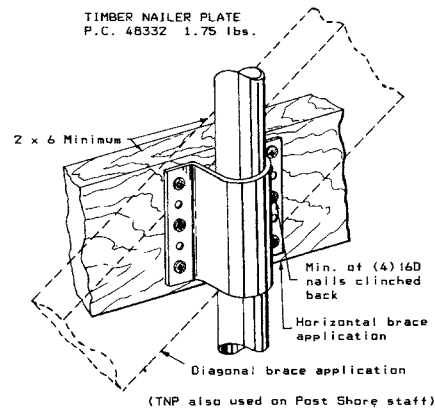

Fig. 26

3. Heavy Duty Post Shores

Symons Heavy Duty Post Shores (Fig. 27) are available in three models providing adjustable shoring heights from 5'-7" to 16' (Fig. 28). The Post Shores carry safe load ratings of up to 10,000 lbs. Despite their high load rating, they are still light enough to be carried by one person. A Post Shore is composed of a base post with threaded collar, and staff member which fits into the base post. Post Shores have a unique locking pin that, under normal use conditions, can't be broken or lost. For approximate height adjustment, a locking pin is inserted into one of the holes spaced at 4" intervals along the staff length. A safety pin secures the locking pin and eliminates accidental slippage of the base and staff. After the Post Shore has been set in position, a threaded collar with handle permits fine height adjustments over a 6" range. The Quick Release Collar (QRC), located immediately above the threaded collar, is used for stripping. A hammer blow to the QRC allows the staff to drop approximately 3/4" and then the threaded collar assembly to be turned down easily.

CAUTION: Do not hammer the threaded adjusting collar handles or ears, as the castings may crack, resulting in failure of the collar and possible collapse of the shoring. The threaded collar is intended to be used to grade the formwork before the pour. Do not use it to lift concrete loads during or after the pour.

CAUTION: Post Shores must be braced as recommended by the Scaffolding, Shoring and Forming Institute, Inc.

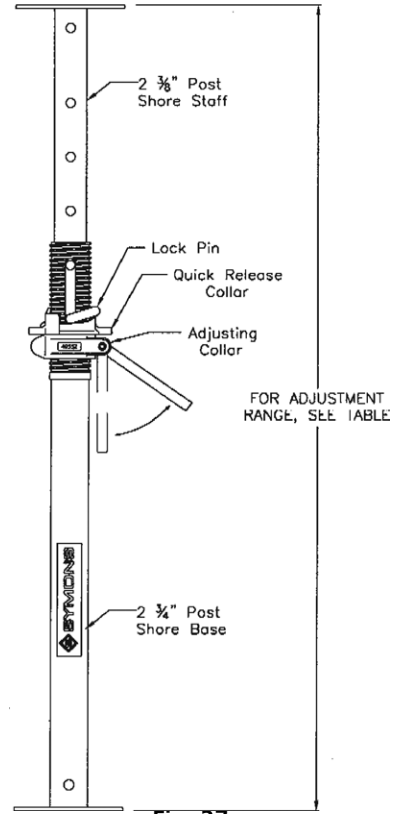

Fig. 27

| | Post Shore #1 | Post Shore #2 | Post Shore #3 |
|---------------|---------------|--------------------|----------------|
| Range | 5'7" to 9'6" | 7'3" to 12'10" | 8'10" to 16'0" |
| Weight | 49 lbs. | 59 lbs. | 74 lbs. |
| Height | | Load Rating (lbs.) | |
| 8' | 10,000 | 10,000 | -- |
| 9' | 10,000 | 10,000 | 10,000 |
| 10' | -- | 10,000 | 10,000 |
| 11' | -- | 10,000 | 10,000 |
| 12' | -- | 8,800 | 10,000 |
| 13' | -- | -- | 8,850 |
| 14' | -- | -- | 7,200 |
| 15' | -- | -- | 5,500 |
| 16' | -- | -- | 3,900 |

Fig. 28

4"x8" U-Head

To support W8x10 steel stringer, Aluminum Joist stringer, or 4" lumber stringer, the 4" x 8" U-Head (Fig. 29) is inserted into the Post Shore staff through the end plate hole and secured by the 1/2" dia. attachment pin and hairpin clip. Nail holes on side of U-Head provide a convenient means of securing lumber stringers. The Steel Beam Clamp should be used to secure the steel stringers to the U-Head.

CAUTION: The 4"x8" U-Head or the 5"x8" J-Head are not to be used in the leg of a FrameFast shore frame.

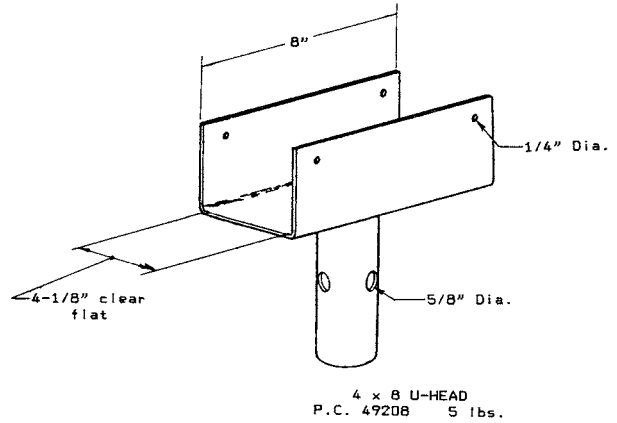

Fig. 29

5"x8" J-Head

The 5"x8" J-Head (Fig. 30) is used at the top of the Heavy Duty Post Shore to support a Symons Aluminum Beam stringer. The J-Head must be pinned to the top of the Post Shore using the 1/2" diameter attachment and hairpin clip. A Steel Beam Clamp or Aluminum Attachment Clip Assembly should be used to secure the Aluminum Beam to the J-Head. Do not use this product in a FrameFast Shoring Frame.

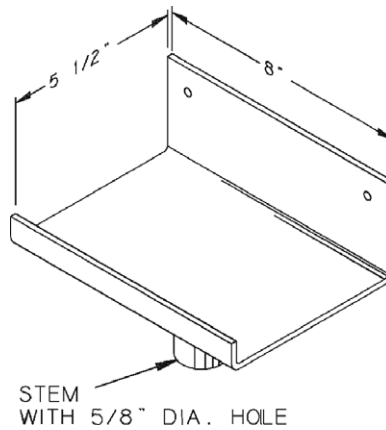

Fig. 30

Post Shore Timber Brace Nailer Plate

This plate has the same shape and function as the Timber Brace Nailer Plate for the FrameFast Shoring Frames except that it is made for 2 3/4" diameter pipe (post shore base tube). It can be easily differentiated from the Timber Brace Nailer Plate, by a 3/4" diameter hole on the curved portion of the plate (Fig. 31). Both of these plates are actually used for the Post Shore bracing; one for the staff member and the other for the base post.

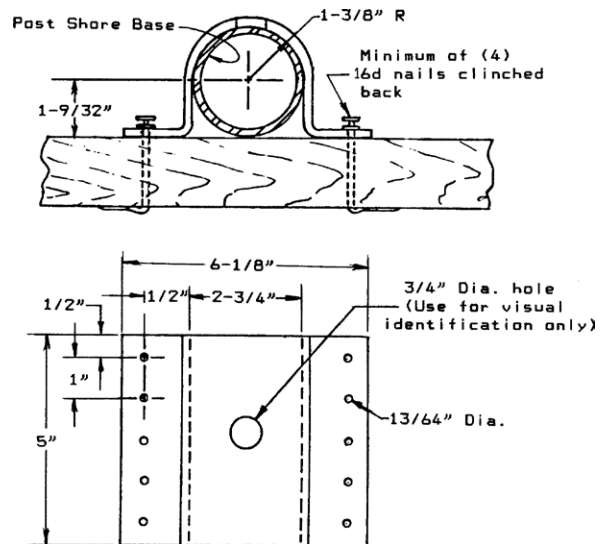

Fig. 31

IV. ERECTION PROCEDURES

Site Preparation

The proposed shoring area should be cleared of all obstructions well ahead of shoring erection. Care should be exercised in determining the capacity of the soil for every shoring job, realizing that weather conditions can turn an otherwise suitable ground condition into a hazardous situation. If fill is required in shored areas, a qualified engineer should be consulted as to materials and compaction. A solid concrete foundation pad on grade, or a mud sill may be required, depending on the load, soil and weather conditions, to distribute the shoring load over a suitable ground area.

If erected on a pan or grid dome floor, or any other floor system involving voids, suitable sills should be used to avoid concentration of an undesirable load on a thin slab section.

CAUTION: Symons does not provide the sill or soil-condition design. Size and bearing capacity of sill plates, soil bearing limitations, and control are the responsibility of the contractor.

Erection on Flat Surface

1. Level the surface as described earlier and mark the shore leg locations according to the layout drawings.
2. Place the sills firmly, as required by the sill design.
3. Distribute base units of each tower for entire area before erection is started. Base unit components are four screw jacks or base plates (Fig. 32 ①), two crossbraces (③), and two frames (④).
4. Adjust screw jack handle to approximately required height. It is easier to make adjustment before tower load is on jack. Insert the screw jack into the bottom of the leg while frames are on the ground.

CAUTION: Do not hammer the adjusting nut handles or ears, as the castings may crack, resulting in failure of the collar and possible collapse of the shoring. The handle nut is intended to be used to grade the formwork before the pour. Do not use it to lift concrete loads during or after the pour. When stripping, tap the handle nut in the direction to release load until it can be turned by hand.

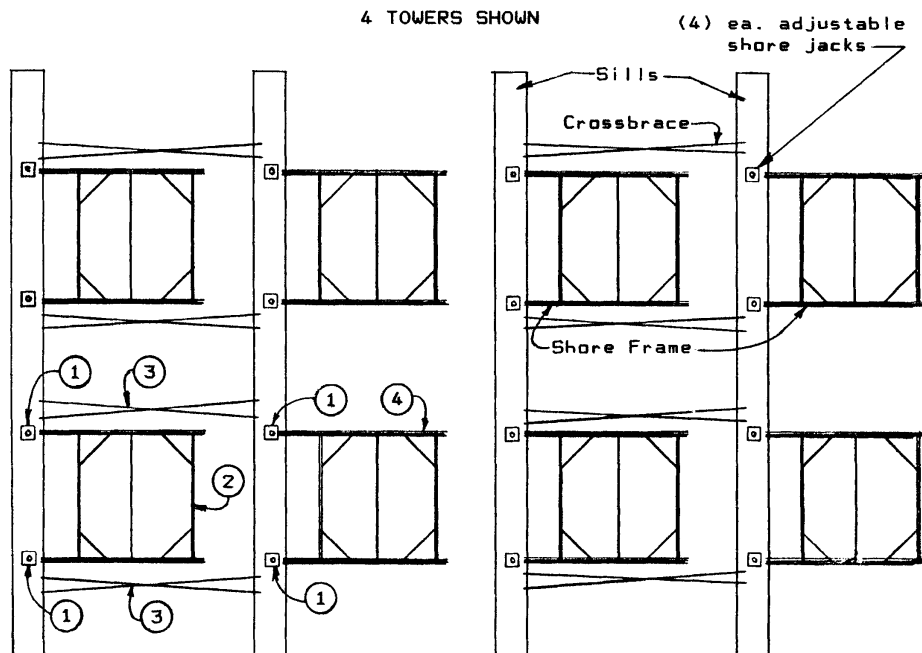

Fig. 32

- Tilt up a frame on sill and install one cross brace. Allow end of cross brace to rest on the opposite side frame sill. Raise the opposite side frame on sill and attach free end of the cross brace. Install second cross brace to frames (Fig. 33)

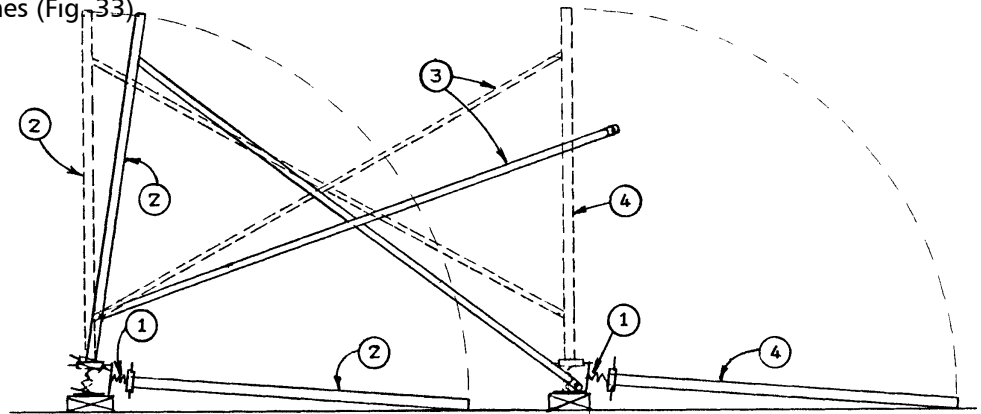

Fig. 33

- Plumb tower with bottom jacks, using a carpenter's level (Fig. 34). One complete turn of jack handle equals 1/4" up or down. It is very important that the base unit is plumbed and accurately positioned to make the following operations easier.

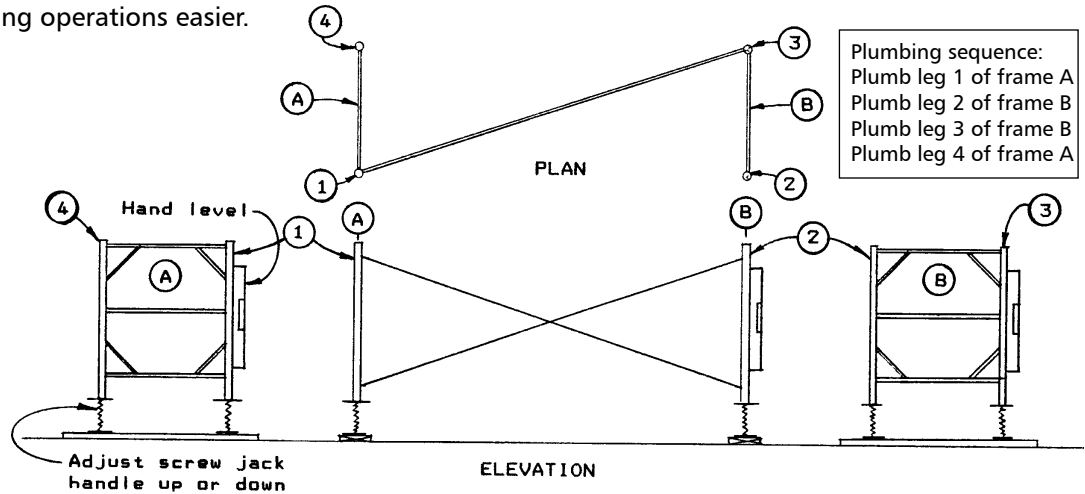

Fig. 34

- Once step six is completed for the whole area, distribute second and third lift components, leaning them against the erected base unit (Fig. 35 and 36). Second lift unit is composed of two frames, two cross braces, and four coupling pins. If there is a third lift, the unit is same as for the second lift.

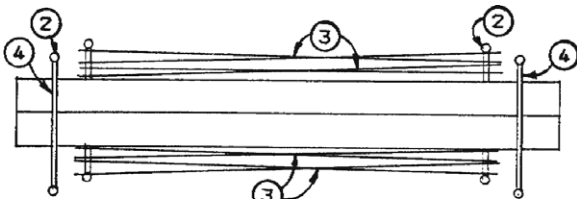

Fig. 35

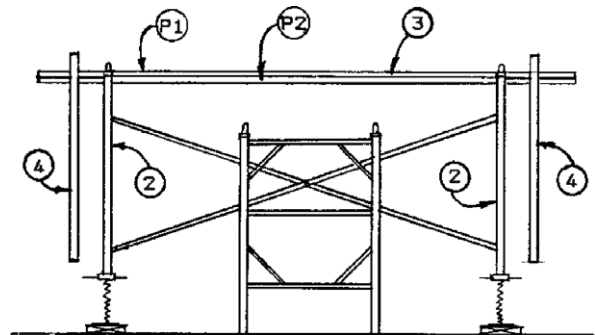

Fig. 36

8. Place the coupling pin into each of the frame tops with the tapered end up, and install 1/2" Attachment Pin or 5/8" Rivet Pin and Hairpin Clip as needed.
9. Place work plank and cross braces level across the top ledgers of the base frames, as the tiers are erected.
10. Raise the second lift frames and install by placing each leg over the coupling pins. Install 1/2" dia. Attachment Pin and Hairpin Clip as needed.
11. Install cross braces as described earlier (Fig. 37).
12. Repeat steps until tower reaches the designed configuration. However, from lift 3 to the maximum height, raise the frames from inside the tower to avoid eccentric loads that could cause tipping of the tower (Fig. 38). At the top of the tower, install screw jacks and U-Heads as needed.
13. Check the overall plumbness and elevation, and adjust as needed.
14. When the height-to-width ratio reaches 4:1, lateral bracing must be installed before proceeding any higher. Timber Nailer Plates and 2x6 minimum lumber (Fig. 26) is used for this purpose.
15. Install stringer on shore head. Stringers must be clamped or restrained to prevent rotation.
16. Set joist and plywood deck into position.
17. Check and set to the final grade. Final grade is made with top screw jacks only. Allow for compression of lumber and settlement of sills.

Erection on Sloped Surface

CAUTION: Erection on sloped surfaces may result in instability of the towers during pouring. Always refer to layout drawings for erection on sloped surfaces.

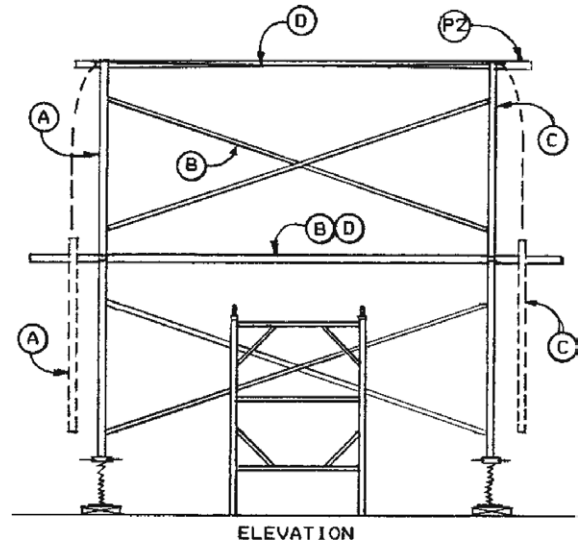

Fig. 37

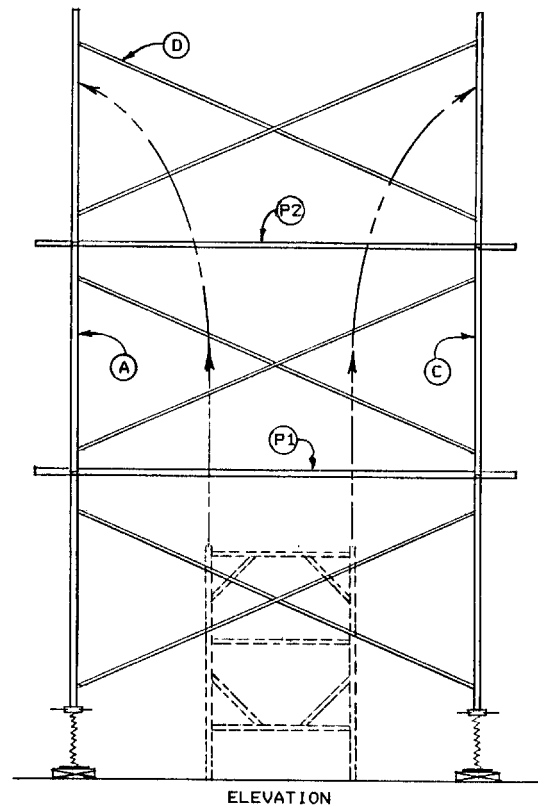

Fig. 38

V. INSPECTION

Material Inspection

The three main areas of inspection for materials are for rust, straightness of members and welds. This applies to all components of shoring systems.

1. **RUST**—heavily rusted shoring equipment is a tell-tale sign of abuse or neglect. Since it may reduce the overall capacity of the system, heavily rusted equipment should be replaced.
2. **STRAIGHTNESS OF MEMBERS**—Mishandling, trucking and storing may cause damage to shoring equipment. All members or parts of all steel shoring components should be straight and free from bends, kinks or dents. Any equipment exhibiting lack of straightness should be replaced.
3. **WELDS**—Equipment should be checked before use for damaged welds. Any piece of equipment showing damaged welds or rewelding beyond the original factory weld should not be used.

While rust, straightness and welds are of primary concern, other component parts should be checked.
4. Look for shoring material by other manufacturers.

CAUTION: Frames and accessories manufactured by others must not be intermingled with Symons frames, as different safety factors and dimension tolerances may be used, and may result in failure.

5. Locking devices on frames and braces shall be in good working order, and if not, must be repaired or replaced prior to use.
6. Coupling Pins must effectively align the frame.
7. Look for cracked adjusting nut castings and handles on jacks.

CAUTION: Do not hammer the Adjusting Collar handles or lugs to lift loads, as the castings will crack, resulting in failure of the collar and possible collapse of the shoring.

8. Cross braces must have the center pivots both securely in place.

If any of the above items are in doubt, they should be directed to a Symons representative for further evaluation.

Field Erection Check With Symons Shoring Layout
The following is a list of check points to be covered by the contractor when making a final inspection of shoring equipment prior to the placing of concrete. Federal regulations, as well as some state and local regulations, require that a shoring layout be available at the jobsite. All points should be carefully checked to ensure a safe and accident-free job.

1. Check to see that there is a sound footing, or sill, under every leg of every frame on the job. Check also for possible washout due to rain.

CAUTION: Always check all sills after other trades have completed their work, and before loading, to be sure of the structural integrity of the sills.

2. Check to make certain that all Base Plates or Adjustment Screws are in firm contact with the footing or sill. All Adjustment Screw handle nuts should be snug against the legs of the frame.
3. Obtain a copy of the shoring layout that was prepared for this specific job. Make sure that the spacings between towers and the cross brace spacing of the towers do not exceed the spacings shown on the layout. If any deviation is necessary because of field condition consult with the Symons representative for required revisions to the layout drawings.
4. Frames should be checked for plumbness in both directions. The maximum allowable tolerance for a frame which is out of plumb is $\frac{1}{8}$ " in 3'. If the frames exceed this tolerance, the base should be adjusted until the frames are within the tolerance.
5. If there is a gap between the lower end of one frame and the upper end of another frame, it indicates that one Adjustment Screw must be adjusted to bring the frames in contact. If this does not help, it indicates the frame is out of square and should be removed.
6. Check that all cross braces have been installed, and no cross braces have been inadvertently left out or purposely removed. While checking the cross braces, also check the locking devices to assure that they are all in their closed position and that they are all tight.
7. **Check the Coupling Pin connections to see whether any air gap exists between Coupling Pin and the shoring frame.**
8. Check the upper Adjustment Screw or Shore Head to assure that it is in full contact with the formwork. If it is not in contact, it should be adjusted or shimmed until it makes contact.

9. Check to see that the obvious mistakes of omitting joists, using the wrong size ledger, or timber placed flat, have not been made. Check the layout drawing to see that the lumber used meets the design limitations assumed on the drawing. Check the general formwork scheme to make sure that it follows good standard practice for formwork.
10. If the shoring layout shows exterior bracing for lateral stability, check to see that this bracing is in place in the locations specified on the drawing. Check to make sure that the devices which attach this bracing to the equipment are securely fastened to the legs of the shoring equipment.

CAUTION: Guard against overloading the shoring! Frequent causes are: temporary storage of rebar, plywood, lumber, and other construction material; motorized equipment, which can cause unexpected lateral loads when starting or stopping; unusual concrete placement, causing concentrated loads.

Inspection During Pour

The shoring system should be continuously watched by competent contractor personnel during placement of the concrete. Precautions should be taken to protect the watchers and maintain an area of safety for them during placement of the concrete. Some means of communicating with placement crews in case of emergency should be planned in advance.

1. If motorized concrete placement equipment is to be used, be sure that lateral and other forces have been considered and adequate precautions taken to assure stability.
2. Plan concrete pouring methods and sequences to insure against unbalanced loading of the shoring equipment. Take all necessary precautions to avoid uplift of shoring components and formwork.
3. Avoid shock or impact loads for which the shoring may not be designed.
4. The watcher should use telltale devices to check the elevations, camber, and plumbness of the shoring system during pour.

CAUTION: If any serious weakness develops during pour, such as would endanger workers or cause undue settlement or distortion, pouring **MUST** be halted.

5. Tighten wedges and promptly make appropriate adjustments of elevation by jacking or wedging wherever necessary. All adjustment must be made before the concrete takes its initial set. This should be performed under the direction of the responsible individual who understands the construction loading conditions and their impact on the shoring.

CAUTION: Do not hammer the vertical adjusting devices to lift loads, as the castings may crack, resulting in failure of the collar, and possible collapse of the shoring.

6. Although a most critical stage has passed once the concrete is placed, the watcher should remain on duty until the concrete has been screeded and telltale devices show that deflection has ceased.

VI. REMOVAL OF SHORES AND RESHORING

Shoring removal and reshoring are affected by factors only under the control of the contractor and/or the building structural engineer, such as construction schedules, construction loads, and structural integrity of the poured concrete relative to time after placement. Therefore, it is the responsibility of the contractor to work with the building engineer to develop the appropriate designs and plans, suited to the specific building design, and in accordance with the appropriate section of ACI-347, and federal, state and local codes and regulations.

CAUTION: Refer to the following safety rules and publications of the Scaffolding, Shoring and Forming Institute, Inc., during all phases of the shoring operation:

DISMANTLING GUIDELINES FOR SAFE PRACTICES FOR ERECTING FRAME SHORING

SINGLE POST SHORE SAFETY RULES

HORIZONTAL SHORING BEAM SAFETY RULES

RECOMMENDED STEEL FRAME SHORING ERECTION PROCEDURES

INDEX

| | | | |
|------------------------------------|----|---|----|
| 3/4" Plywood | 2 | Inspection During Pour..... | 18 |
| 4"x8" U-Head | 13 | Lumber and Nailer Clip..... | 2 |
| 5"x8" J-Head | 13 | Material Inspection | 17 |
| 8"x8" 7-Hole U-Head | 9 | Meter Screw Jack | 8 |
| 8"x8" U-Head Adapter..... | 8 | Nailer Clip..... | 2 |
| Aluminum Stringer | 5 | Plywood | 2 |
| Attachment or Rivet Pins..... | 11 | Post Shore Timber Brace Nailer Plate..... | 13 |
| Attachment Pins..... | 11 | Quick Release Collar | 12 |
| Clamping Nut..... | 5 | Reshoring | 18 |
| Clip Assembly..... | 4 | Rivet Pins..... | 11 |
| Connection Hardware | 5 | Shoring Frames | 7 |
| Coupling Pin..... | 11 | Shoring Removal | 18 |
| Coupling Pin, Heavy Duty..... | 11 | Site Preparation..... | 14 |
| Crossbraces | 9 | Spacer Bars..... | 9 |
| Erection On Flat Surface..... | 14 | Stringer | 5 |
| Erection On Sloped Surface | 16 | Support System and Accessories | 7 |
| FF/SF Sloping Head Assembl..... | 9 | Timber Brace Nailer Plate | 11 |
| FF/SW Coupling Pin | 11 | W8x10..... | 5 |
| Field Erection Check | 17 | | |
| FrameFast Components..... | 2 | | |
| FrameFast Shore Frame System | 2 | | |
| Hairpin Clips..... | 11 | | |
| Heavy Duty Base Plate | 8 | | |
| Heavy Duty Coupling Pin | 11 | | |
| Heavy Duty Post Shores..... | 12 | | |
| Heavy Duty Post Shore System | 2 | | |

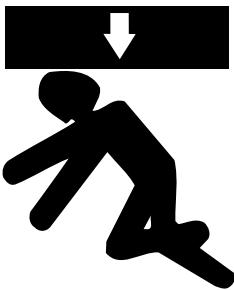
| | |
|---|--|
|  | <p style="text-align: center;">⚠ WARNING</p> <p style="text-align: center;">Improper Use of Concrete Accessories Can Cause Severe Injury or Death</p> <p>Read, understand and follow the information and instructions in this publication before using any of the Dayton Superior concrete accessories displayed herein. When in doubt about the proper use or installation of any Dayton Superior concrete accessory, immediately contact the nearest Dayton Superior Service Center or Technical Service Department for clarification. See back cover for your nearest location.</p> |
|---|--|

Dayton Superior products are intended for use by trained, qualified and experienced workmen only. Misuse or lack of supervision and/or inspection can contribute to serious accidents or deaths. Any application other than those shown in this publication should be carefully tested before use.

The user of Dayton Superior products must evaluate the product application, determine the safe working load and control all field conditions to prevent applications of loads in excess of a product's safe working load. Safety factors shown in this publication are approximate minimum values. The data used to develop safe working loads for products displayed in this publication are a combination of actual testing and/or other industry sources. Recommended safe working loads given for the products in this publication must never be exceeded.

Worn Working Parts

For safety, concrete accessories must be properly used and maintained. Concrete accessories shown in this publication may be subject to wear, overloading, corrosion, deformation, intentional alteration and other factors that may affect the device's performance. All reusable accessories must be inspected regularly by the user to determine if they may be used at the rated safe working load or should be removed from service. The frequency of inspections depends upon factors such as (but not limited to) the amount of use, period of service and environment. It is the responsibility of the user to schedule accessory hardware inspections for wear and remove the hardware from service when wear is noted.

Shop or Field Modification

Welding can compromise a product's safe working load value and cause hazardous situations. Knowledge of materials, heat treating and welding procedures is necessary for proper welding. Consult a local welding supply dealer for assistance in determining required welding procedures.

Since Dayton Superior cannot control workmanship or conditions in which modifications are done, Dayton Superior cannot be responsible for any product altered in the field.

Interchangeability

Many concrete accessory products that Dayton Superior manufactures are designed as part of a system. Dayton Superior strongly discourages efforts to interchange products supplied by other manufacturers with components supplied by Dayton Superior. When used properly, and in accordance with published instructions, Dayton Superior products have proven to be among the best designed and safest in the industry. Used improperly or with incompatible components supplied by other manufacturers, Dayton Superior products or systems may be rendered unsafe.

Installation

WARNING

1. Dayton Superior Corporation products shall be installed and used only as indicated on the Dayton Superior Corporation installation guidelines and training materials.
2. Dayton Superior Corporation products must never be used for a purpose other than the purpose for which they were designed or in a manner that exceeds specific load ratings.
3. All instructions are to be completely followed to ensure proper and safe installation and performance.
4. Any improper misuse, misapplication, installation, or other failure to follow Dayton Superior Corporation's instruction may cause product malfunction, property damage, serious bodily injury and death.

THE CUSTOMER IS RESPONSIBLE FOR THE FOLLOWING:

1. Conformance to all governing codes
2. Use of appropriate industry standard hardware
3. The integrity of structures to which the products are attached, including their capability to safely accept the loads imposed, as evaluated by a qualified engineer.

SAFETY INSTRUCTIONS:

All governing codes and regulations and those required by the job site must be observed. Always use appropriate safety equipment

Design Changes

Dayton Superior reserves the right to change product designs, rated loads and product dimensions at any time without prior notice.

Note: See Safety Notes and Safety Factor Information.

DAYTONSUPERIORBRANDS

CONCRETE ACCESSORIES

Accubrace®
Aztec®
Bar Lock®
Corewall®
Fleet-Lift™
Swift Lift®
Taper-Lock®

CONSTRUCTION CHEMICALS

Unitex®

FORMING PRODUCTS

Symons®
Max-A-Form®
Steel-Ply®
Sym-Ply®

DAYTONSUPERIORPRODUCTS

BRIDGE DECK FORMING

Adjustable Joist Hangers
Bridge Overhang Brackets
Haunch and Fillet Forming
Pres-Steel, Coil Rod and Con-Beam
Hangers
Screed Supports

CHEMICALS

Bond Breakers
Cleaners / Strippers
Concrete Repair/Restoration
Curing Compounds / Sealers
Epoxies
Floor Levelers
Form Release Agents
Grout
Hardeners / Industrial Toppings
Liquid Densifiers
Surface Retarders

FORMINGANDSHORING

Aluminum Shoring
Ganged Formwork
Garage Beam System
Handset Formwork
Highway Forms
Jump Forms
Modular Deck Shoring
One Sided Frames
Self Spanning Forms
Steel Frame Shoring

FORMLINERS

ABS Plastic
Polystyrene Plastic

PAVING

Dowel Bar Expansion Caps
Dowel Bar Retrofit System
Elastomeric and Hot Pour Joint Seal
Metal Keyway Form Systems
Tie Bar Assemblies
Transverse Bar Assemblies
Welded Dowel Assemblies
Wire Baskets without Dowels

PRECAST

Anchors and Lift Systems
Coil / Ferrule Inserts
Core Plugs
Magnets
Precast Forms
Rustications/Chamfers
Sandwich Panel Connector
Shear Connectors
Slotted Inserts

REBAR SPLICING

Forged Dowel Bar Couplers
Lockshear Bolt Couplers
Shear Resistance Products
Straight Thread Couplers
Taper Thread Couplers

REBAR SUPPORTS

Concrete Dobbies
Continuous Plastic and Steel
Bar Supports
Individual Plastic and Steel
Bar Supports
Mesh Chairs
Paving Chairs
Side Form Spacers

TIES AND ACCESSORIES

Modular Form Ties
Single Waler System
Ties and Accessories

TILT-UP

Braces and Brace Anchors
Helical Ground Anchors
Setting Plugs
Strongback System
Tilt-Up Anchors and Lifting Systems

CONTACT INFORMATION



48575 Downing Street
Wixom, MI 48393

800.876.4857

info@formtechinc.com
formtechinc.com

With products proudly made in America and a wide breadth of recognized brands.

99689
03/12

Give us a call at any of our branch locations, email us at info@formtechinc.com, or click on formtechinc.com/quote to get a quote. Our experienced Form Tech representatives will answer your questions, and help you get your project started with some of the best concrete forming, shoring, and accessory products in the industry, backed by a professional and detail-oriented staff.



Charleston, SC

7377 Peppermill Lane
North Charleston,
SC 29418
843.628.3434



Detroit, MI

Corporate Headquarters
975 Ladd Road
Walled Lake,
MI 48390
Branch: 248.344.8260
Corporate: 248.344.8265



Charleston, WV

161 Industrial Road
St. Albans,
WV 25177
304.722.6804



Pittsburgh, PA

2850-A Kramer Road
Gibsonia,
PA 15044
412.331.4500



Charlotte, NC

1000 Thomasboro Road
Charlotte,
NC 28208
704.395.9910



Raleigh, NC

115 Peffinder Lane
Raleigh,
NC 27603
919.833.0911



Cleveland, OH

20801 Miles Road
North Randall,
OH 44128
216.692.0497



TRUSTED FORMWORK & ACCESSORY SPECIALISTS

800-876-4857 | info@formtechinc.com | formtechinc.com